

**SHURflo**<sup>®</sup>*First in Fluid Innovation***PRODUCT DATA SHEET****MODEL: 8001-997-236****SPECIFICATIONS:****MODEL NUMBER:** 8001-997-236**PUMP DESIGN:** Positive Displacement 3 Chamber Diaphragm Pump**CHECK VALVE:** (1-Way Operation) Prevents Reverse Flow**CAM:** 3.0 Degree**MOTOR:** Permanent Magnet, P/N 11-150-06, Thermally Protected**VOLTAGE:** 115 VAC Nominal**PRESSURE SWITCH:** Adjustable Shut-Off (Range 45-65 PSI)Factory Set @ 60 PSI, Turn On 50 PSI  $\pm$  5 PSI**LIQUID TEMPERATURE:** 180 Degrees Fahrenheit (82 Degrees Centigrade) Max.**PRIME:** Self-Priming Up To 11 Ft. Vertical,

Max. Inlet Pressure 30 PSI (2.1 Bar)

**PORTS:** 3/8"-18 NPT Female**MATERIAL OF CONSTRUCTION:****PLASTICS-** Nylon**VALVES-** EPDM**DIAPHRAGM-** Santoprene**FASTENERS-** Zinc Plated Steel**NET WEIGHT:** 3.7 Lbs (1.7 Kg)**DUTY CYCLE:** Intermittent (See Temperature Rise Chart)**TYPICAL APPLICATIONS:** General Ind. / Water**HARNESS:** 3 Circuit Amp Connector w/6ft of Sjeow Cord Included**DIMENSIONS:**

**TEMPERATURE RISE**

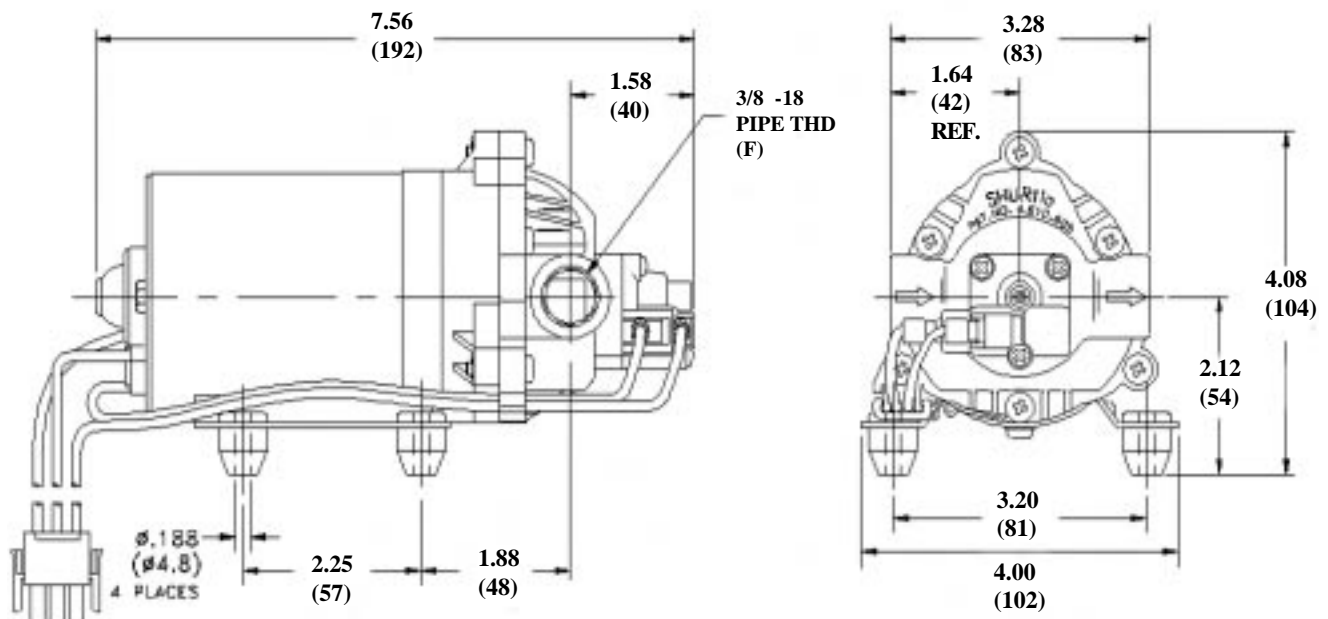
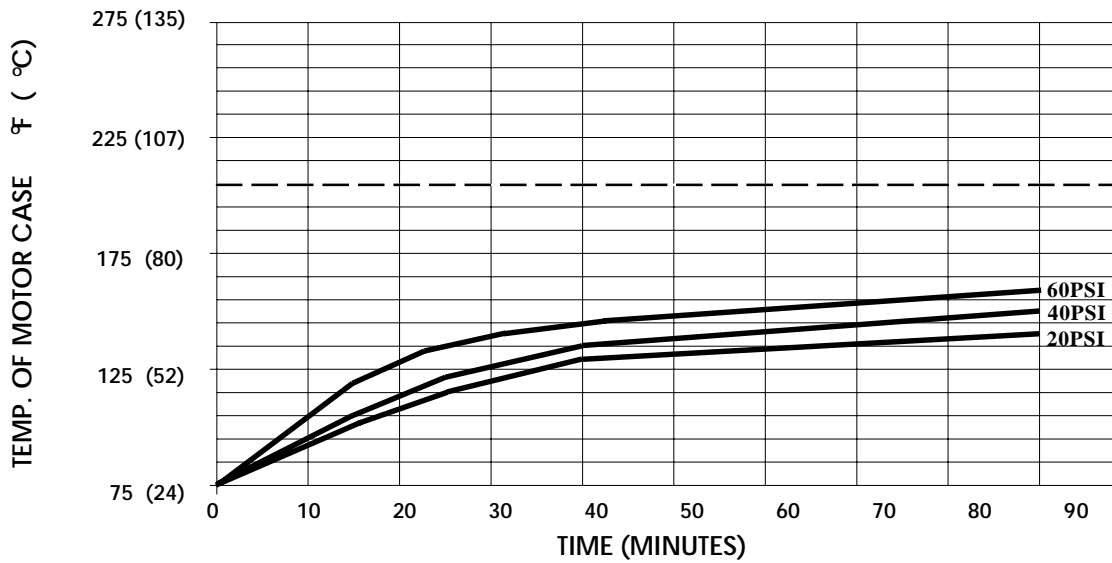

THIS GRAPH IS FOR USE AS A DESIGN GUIDE. IT IS BASED ON RUNNING CONTINUOUSLY WITH AN AMBIENT TEMPERATURE OF 75°F IN STILL AIR. THE THERMAL BREAKER WILL OPEN WHEN THE CASE TEMPERATURE REACHES 205° F.

[----- TRIP POINT OF THERMAL PROTECTOR]

**TYPICAL PERFORMANCE**

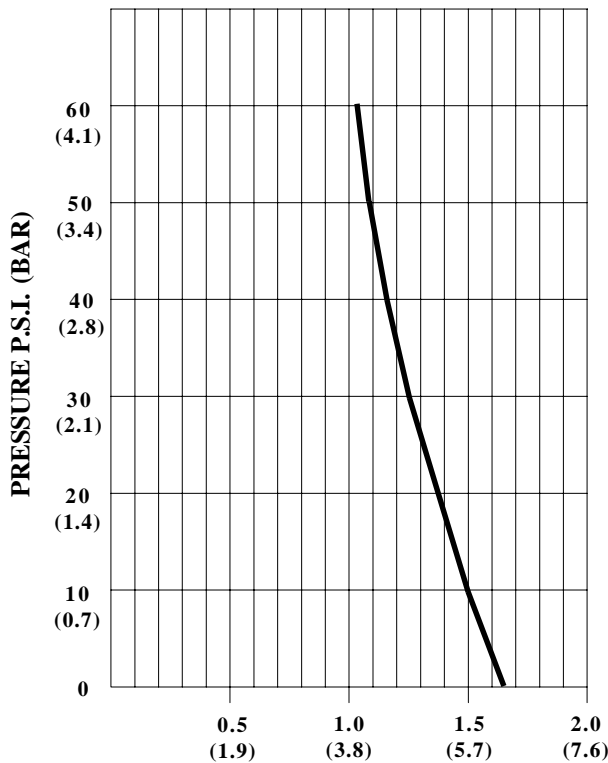

PRESSURE (PSI)	FLOW (GPM/LIT)	RPM MIN/MAX	CURRENT (AMPS)	VOLTAGE (VOLTS)
OPEN	1.64/6.2	2140/2160	0.31	115VAC
10	1.50/5.7	2015/2050	0.35	"
20	1.36/5.1	1900/1915	0.41	"
30	1.25/4.7	1770/1800	0.46	"
40	1.16/4.4	1655/1685	0.50	"
50	1.08/4.1	1565/1590	0.57	"
60	1.02/3.9	1510/1530	0.61	"

FLOW - GALLONS PER MINUTE (LITERS PER MINUTE)

-SPECIFICATIONS SUBJECT TO CHANGE WITHOUT NOTICE.

ALL DATA BASED ON TESTING WITH WATER AT AMBIENT TEMPERATURE.

For technical advice or service please take your pump into your local pump service center.

To order pump or parts or for pricing please go to the following links :

[Shurflo Pumps Home >>](#)

[Shurflo Pumps stock list >>](#)