

**SHURflo****MARINE** PRODUCT DATA SHEET

**OEM: 358-000-00 (1500 GPH)**  
**AFTERMARKET: 358-000-10 (1500 GPH)**

Heavy duty and built to last. SHURflo's 1500 nylon bilge pump offer a unique motor cooling system (patent pending) to ensure efficient performance and long life. Installation is a snap with our patented swivel base and 6' tinned wire assembly.

**TYPICAL APPLICATIONS**

12V Marine Bilge Water Evacuation. For other applications, Contact SHURflo.

**PUMP**

Type: Centrifugal Pump  
 Port: 1 1/8" Barb  
 Liquid: 130 °F [54 °C] Max  
 Prime: Flooded Inlet  
 Inlet PSI: N/A  
 Run Dry: No

**ELECTRICAL**

Motor: 12VDC Permanent Magnet, Continuous Duty  
 Protection: External Fuse  
 Leads: 6 ft (1.8M) Tinned, 16 AWG  
 Fuse: 10 Amp Recommended  
 Control: No Control

**MATERIALS**

Housing: High Strength Nylon  
 Impeller: High Strength Nylon  
 Hardware: Stainless Steel

**APPROVALS**

Ignition Protected, CE, ISO 8846

**WARRANTY**

3 Year Limited Warranty  
 See SB-1050 For Full Warranty Details

**SHIPPING**

Net Weight (Boxed): Lb ( Kg) each  
 Carton Weight: Lb [13.6 Kg]  
 Pumps in Carton: 8  
 Carton Size: "L x "W x " H [cm x cm x cm]

**RELATED DOCUMENTS**

Catalog: MS-030-140  
 Installation Manual: 911-742  
 Maintenance: 911-742  
 Applications Spec Guide: MS-020-005  
 Warranty: SB-1050

**Replacement Kit**

94-007-01



PERFORMANCE @ 13.6V DC

PRESSURE		FLOW		CURRENT
METERS	FT OF HEAD	GPH	LPH	AMPS
0.0	0	1800	6813	7.75
1.20	4	1650	6442	7.5
2.40	8	1400	5299	7.0

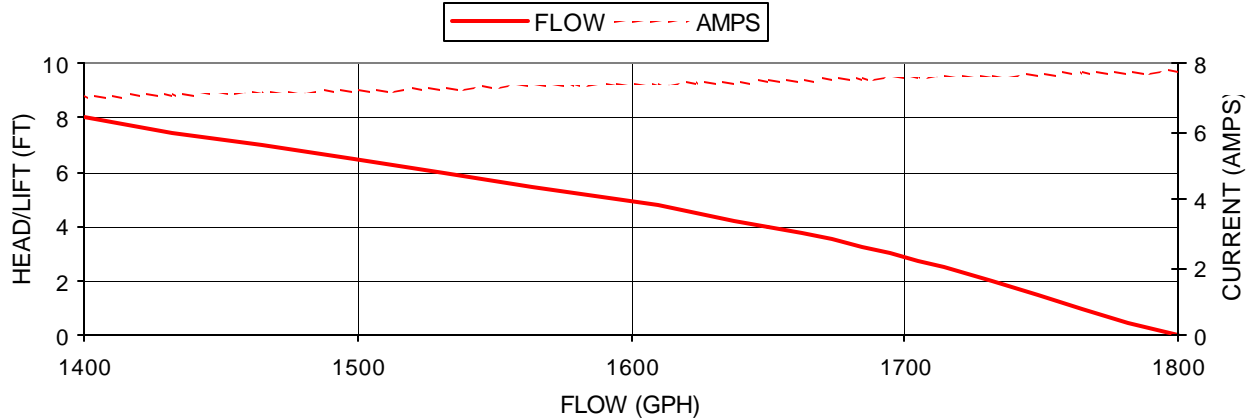

DIMENSIONS [mm]

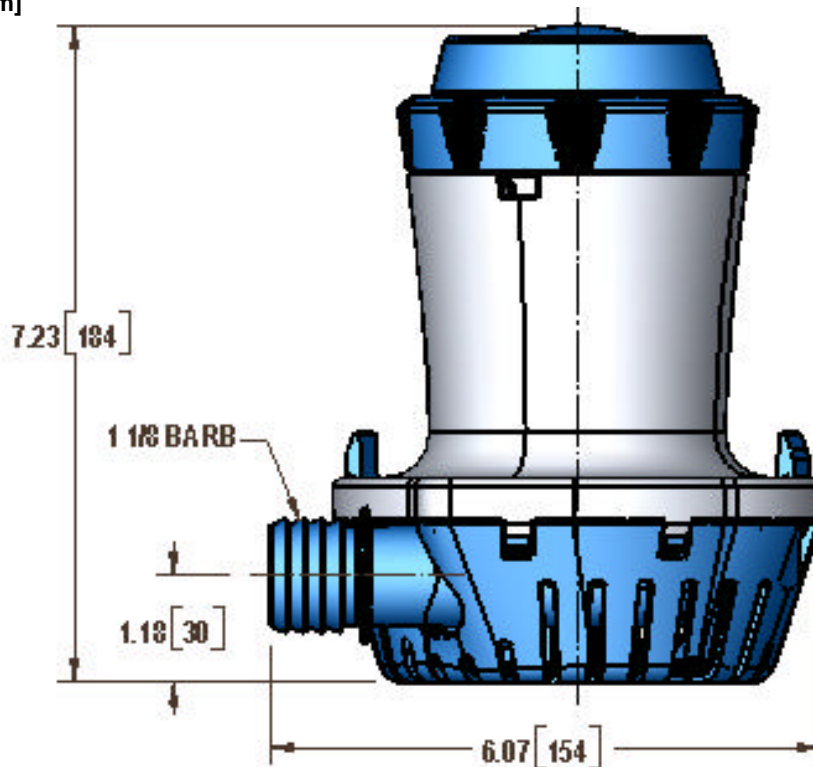

For technical advice or service please take your pump into your local pump service center.

To order pump or parts or for pricing please go to the following links :

[Shurflo Pumps Home >>](#)

[Shurflo Pumps stock list >>](#)