



A WILO COMPANY

Marine Bronze Motorpump™

1 x 3/4 NPT 2 Pole 50-60 Hz 2900-3450 RPM

Group - 35000

Model - **35069-2**

Pump

- All Bronze marine centrifugal pump
Freshwater or seawater applications
- Precision machined to close tolerances for consistent performance.
- Hardware - Type 303 stainless steel
- Semi-open impeller handles solids
- Impeller mounted on motor shaft
- Heavy-duty, designed for continuous 24 hour – 7 day operation.
- Stainless steel shaft

Shaft Seal

- Rated at 75 PSI – 5 BAR
- Seawater Buna rubber parts, ceramic stationary and carbon rotating element, stainless steel spring and metal components

Motor – 2 Pole

- Totally enclosed fan cooled IP-44 motors meet marine, European, and Coast Guard ignition protected requirements.
- Sealed ball bearings
- Single-phase capacitor start
50 Hz - 110/220 Volt 60 Hz - 115/230 Volt
- Three phase motors are not available
- Dual frequency 60 Hz or 50 Hz single phase motors are available

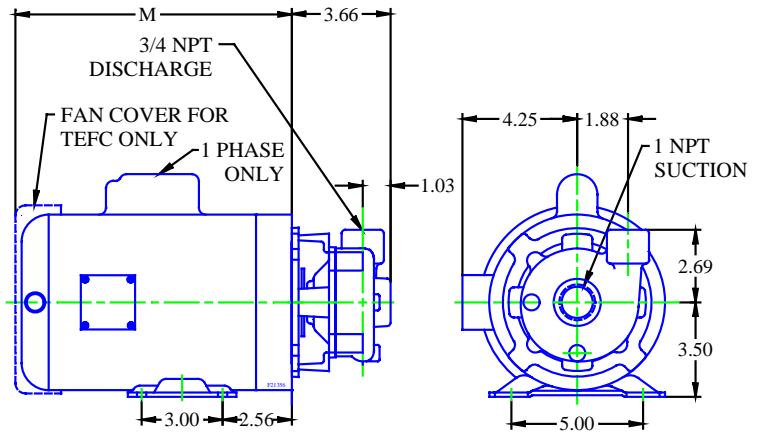

Motorpump 35069-2

Motor HP		M Dim	Wt. lbs	Amperes - TEFC	
50 Hz	60 Hz			50 Hz 220 V	60 Hz 230 V
1/3	1/3	9.00	30	3.9	3.5

Amps for 115 V 60 Hz is double 230 V amps

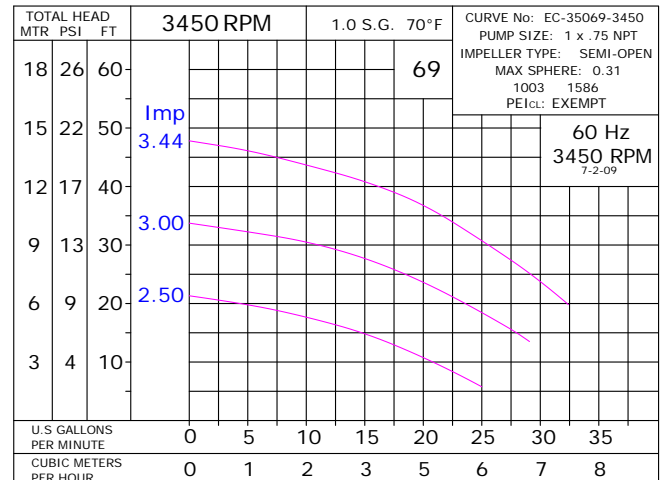
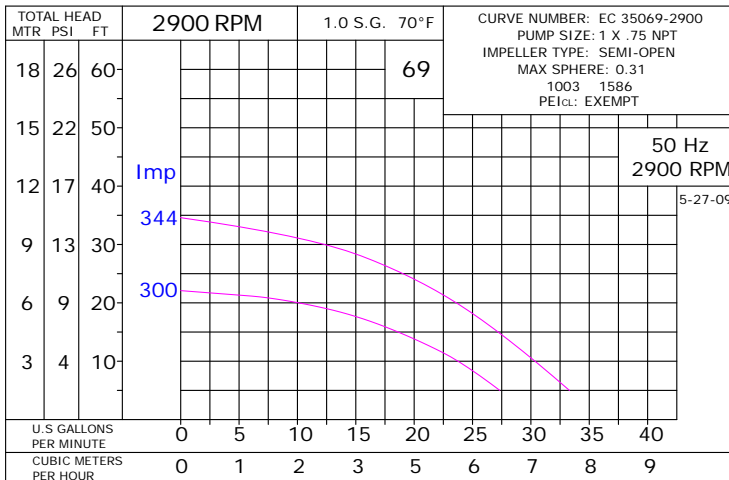

Pump 35069 • Bronze • J56 Frame • 3500 RPM

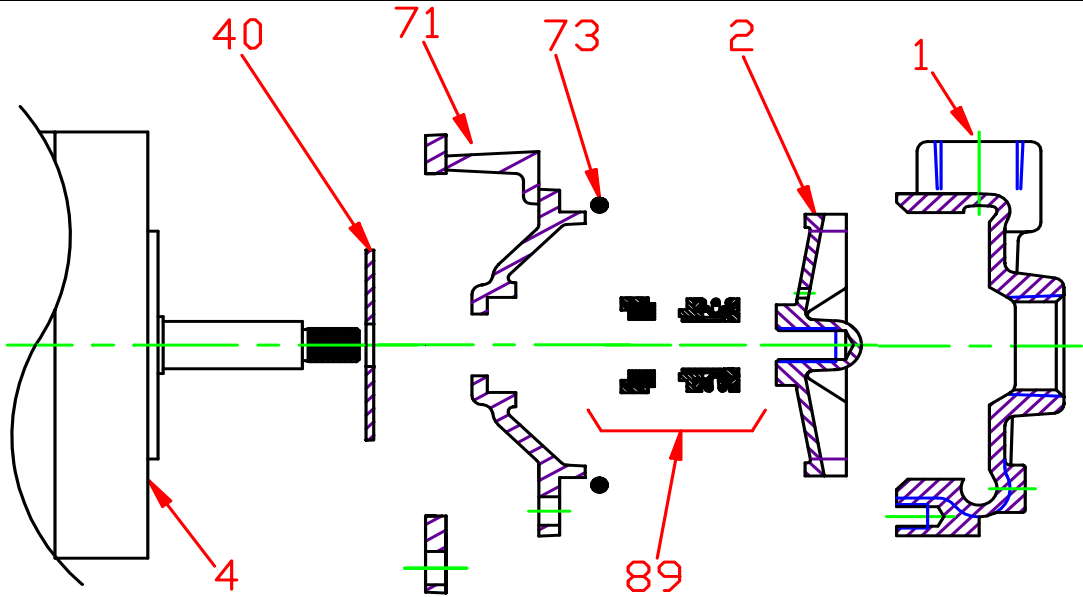

KEY NO.	PART NAME	PUMP 35069
1	CASE, BRONZE, 1 x 3/4 NPT	130.000.284
2	IMPELLER, BRONZE, 7/16" THREADED, SEMI-OPEN	
	2.50	131.000.689.250
	3.00	131.000.689.3.00
	3.44	131.000.689.344
4	MOTOR: J56, 3.5" RIGID BASE	See Chart
40	FLINGER, NEOPRENE	104.000.171
71	ADAPTER, BRONZE	132.000.297
73*	GASKET, CASE, BUNA	116.000.153
89*	5/8" SEALS: NO RETAINER:	
	TYPE 6, BN-CARB/CM	101.000.110
--	SEAL AND GASKET KIT:	1 PHASE:
	BN-CARB/CM SEAL	189.001.116

* DENOTES COMPONENTS INCLUDED IN SEAL AND GASKET KIT.

F21734-1

F17

P35069

Pump 35069 • Bronze • J56 Frame • 3500 RPM

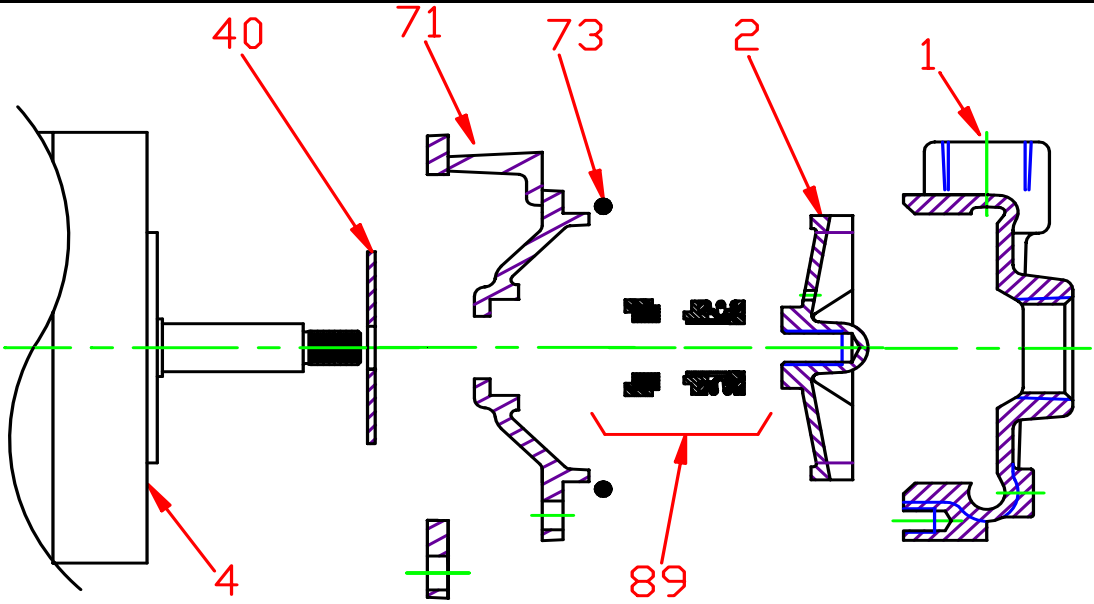

CONSTRUCTION OPTIONS		
KEY	PART NAME	ALL BRONZE
1	Case	Bronze
2	Impeller	Bronze
40	Flinger	Neoprene
71	Adapter	Bronze
73	Gasket, Case	Buna
89	Mechanical Seal, Type 6, BN-CM	Standard

F21734-1

F17

C35069