

INSTRUCTIONS & REPAIR PARTS FOR 320 PUMPS

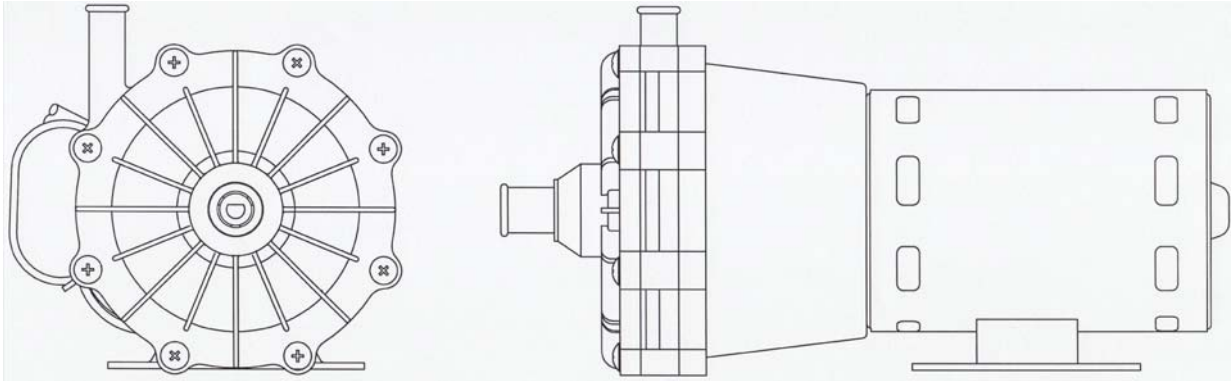

For applications requiring low flow, but when it's necessary to develop pressure. This compact sized corrosion resistant pump has the durability of a centrifugal pump for continuous duty.

- Ideally suited for use in:
- Electronic Industry
 - Laser Cooling
 - Medical Systems
 - Filter Systems
 - Micro Chip Processing

SPECIFICATIONS

Model	Max. Flow GPM	Max. Head Ft.	Max Internal Pressure Inlet	Max. Liquid Temp	Inlet	Outlet	HP	RPM	Volts	PH	Hz	Amp	Watts	Materials in Contact with Solution	Wt. Packed Lbs.
320-AP-MD	3.3	39.5	50	190°F	5/8" OD Smooth	1/2" OD Smooth	1/12	3450	115	1	50/60	1.3	150	Glass filled polypropylene, Ceramic Spindle and thrust washers, Viton® O Ring	10
320-CP-MD	3.3	39.5	50	190°F	1/2"-14 MPT	3/8"-18 MPT	1/12	3450	115	1	50/60	1.3	150	Glass filled polypropylene, Ceramic Spindle and thrust washers, Viton® O Ring	10

PUMP CONSTRUCTION & SERVICING

March Centrifugal Magnetic Drive Pumps eliminate the conventional shaft seals found in most pumps. This means that there is no rotating seal to wear and allow the liquid being pumped to leak out. The Model 320 has an open air fan cooled, moisture protected motor, rated for continuous duty.

All pumps are serviceable with the use of a screwdriver. The only moving part in the pump, other than the motor, is the impeller-magnet assembly. This assembly rotates on a stationary spindle and up against a thrust washer. These are the only parts that can wear, and may need to be replaced. See the Repair Parts List for replacement parts.

ELECTRICAL & OPERATION

All models are standard in 115 volt, 50/60 cycle, 1 phase, A.C. The motors are thermal overload protected, and the motor and overload combinations are U.L. and C.S.A. list-ed.

All cord sets are U.L. approved 18/3 wire, SJO or SJT cords. The AC style pumps have 3 foot long cords with no plug attached. 230 volt motors are available.

Pumps are not self priming and will not produce a suction lift and must be installed with a positive flooded suction. March Pumps utilize the liquid being pumped to lubricate the impeller-magnet assembly rotating on the stationary spindle, and therefore they should not be run dry. Contact the factory for special applications.

PUMP MATERIALS

Screws are type 18-8 stainless.
 "O" ring gaskets are viton® rubber.
 Spindle & Thrust Washers are ceramic.
 All wetted plastic parts are Glass Filled Polypropylene.
 Motor bracket is Glass Filled Polypropylene.
 Other materials are available, contact the factory for assistance.

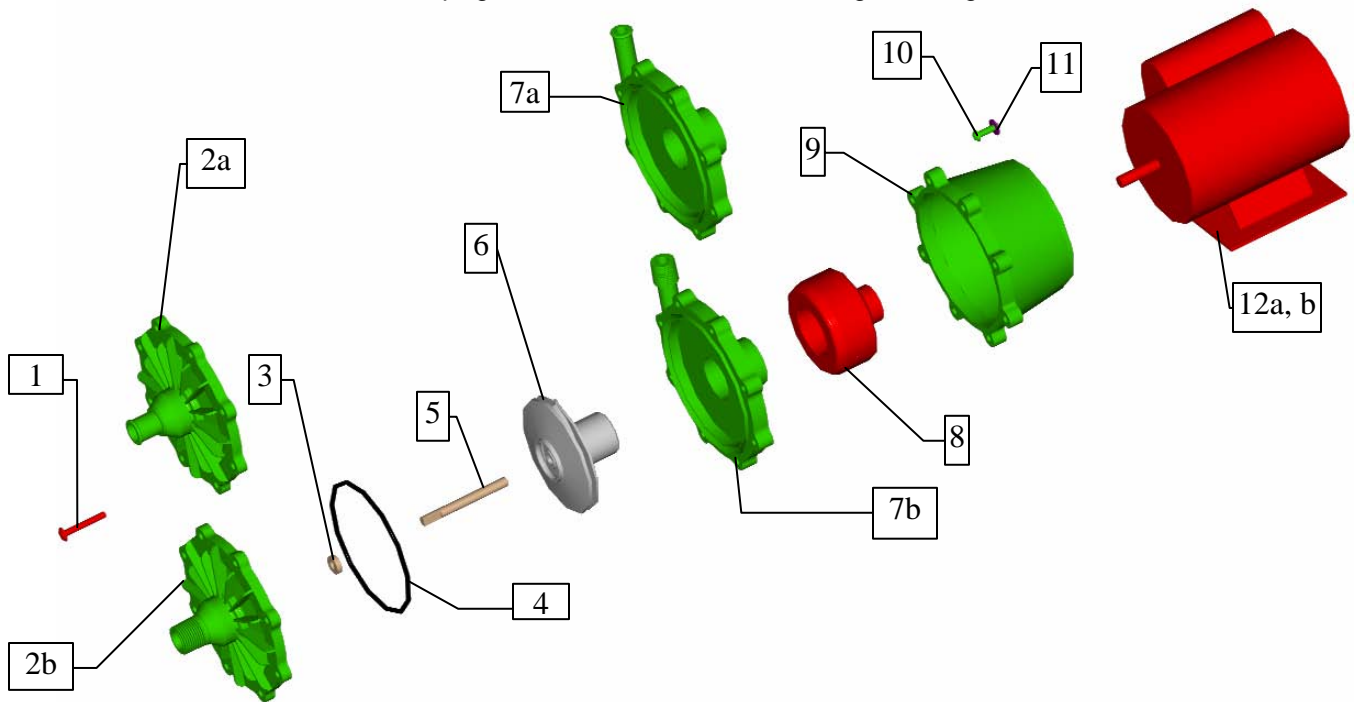

MODEL 320 REPAIR PARTS LIST			
ITEM	DESCRIPTION	QUANTITY	PART NUMBER
1	#8 – 32 x 1 ¼" Long Screw	8	0320-0008-1000
2a	Cover (5/8" O.D. Inlet)	1	0320-0003-1000
2b	Cover (1/2" MPT Inlet)	1	0320-0011-1000
3	Thrust Washer (Ceramic)	1	0130-0028-1000
4	O'Ring, 3.622" I.D. x .118" thk (Viton)	1	0320-0006-1000
5	Shaft (Ceramic)	1	0130-0024-1000
6	Impeller Magnet Assembly (Encaps)	1	0320-0004-0300
7a	Rear Housing (1/2" O.D. Outlet)	1	0320-0002-0100
7b	Rear Housing (3/8" MPT Outlet)	1	0320-0010-0100
8	Drive Magnet Assembly	1	0130-0043-0200
9	Motor Bracket	1	0320-0007-0100
10	#8 – 32 x 5/8" Long Screw	4	0618-0027-1000
11	#8 Washer	4	0135-0016-1000
12a	Motor, 115V (AC)	1	0145-0012-1000
12b	Motor, 230V (AC)	1	0145-0029-1000

Contact factory for other materials and/or parts not listed.

LIMITED WARRANTY

March pumps are guaranteed only against defects in workmanship or materials for a period of one year from date of manufacture pumping water. On all other solutions, contact the factory for application assistance. March Pump Application Worksheet 750-130-10 is available for additional warranty information.



MARCH MANUFACTURING, INC.

1819 PICKWICK AVE., GLENVIEW, IL 60026-1306, U.S.A