

# INSTRUCTIONS & REPAIR PARTS FOR MODELS DP-6T-MD, TE-6T-MD AND TE-6K-MD



DP-6T-MD



TE-6T-MD  
TE-6K-MD

## RATINGS AND SPECIFICATIONS

MODEL NO.	CONNECTORS		ELECTRICAL			G.P.M AT LISTED HEAD						PSI GAGE	DIMENSIONS			PACK WT.
	INLET	OUTLET	HP	WATTS	AMPS	3 FT.	10 FT.	20 FT.	30 FT.	40 FT.	45 FT.		HT.	WD.	LG.	
DP-6T/K-MD	1" FPT	¾" MPT	½	620	8.8/4.4	36	34	30	25	16.5	1	19.6	8⅞	8⅞	15-3/16	28 lbs.

## PUMP CONSTRUCTION & SERVICING

March "Orbital" Magnetic Drive Pumps eliminate the conventional shaft seals found in most pumps. This means that there is no rotating shaft or seal to wear and allow the liquid being pumped to leak out. The only seal in the pump is a stationary Viton "O" ring seal between the Cover and the Pump Housing.

The pump can be serviced with the use of a wrench. The only moving part in the pump other than the motor, is the Impeller-Magnet Assembly, which rotates on a stationary ceramic spindle an up against a ceramic thrust washer. These are the only parts that might wear, and may require replacement. See the Repair Parts List for replacement parts.

## ELECTRICAL AND OPERATION

The D.P. pump has a Drip Proof motor and the T.E. pump has a totally enclosed fan cooled motor. Both motors are 115/230 volts, 50/60 cycle, 1 phase, 3450 R.P.M. rated as continuous duty. At 115 volts the motor draws 8.8 amps and at 230 volts draws 4.4 amps at full load. A junction box is located on the rear of the motor for making the electric hook up. The wiring instructions are located on the motor label or on the junction box cover. The motor is thermal overload protection and has U.L. yellow card recognition.

Pumps are not self priming and will not produce a suction lift and must be installed with a positive flooded suction. The liquid being pumped serves as the lubrication for the Impeller-Magnet assembly spinning on the stationary ceramic spindle. If the pump is run dry for longer than 30 seconds, the Impeller may "freeze" onto the spindle. The direction of motor rotation should be clockwise looking into the inlet of the pump. A carbon bushing will enable dry running protection.

Totally enclosed explosion proof and 3 phase motors are available upon special order.

## PUMP MATERIALS

All plastic parts of the pump are molded out of Ryton R4<sup>®</sup>, Polypropylene, or Kynar<sup>®</sup>. The stationary spindle and Thrust Washers are made of porcelain ceramic. The "O" ring for the housing is Viton rubber. The bushing in the Impeller Assembly is a molded Carbon/Teflon/Ryton material. There are no other materials in contact with the solution. Contact the factory for other materials that are available and if you are uncertain of the material compatibility with your specific solution. U.L. recognition on the pump is for water only. For pumping liquids other than water, contact the factory.

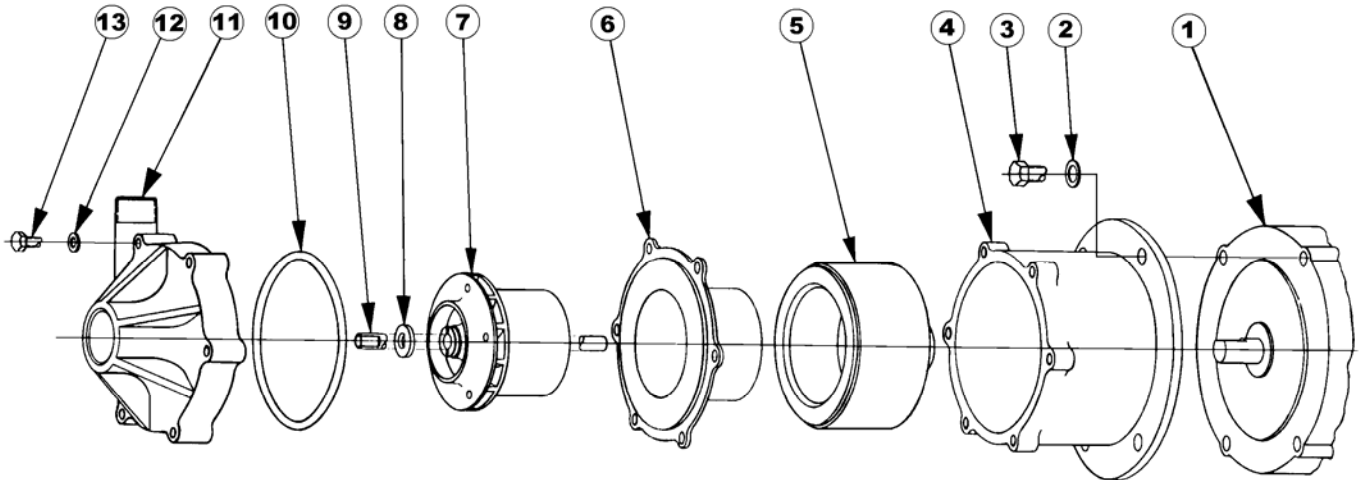

**NOTE:** WHEN REPLACING IMPELLER BUSHINGS IN THE FIELD, THE PLASTIC BUSHINGS MUST BE BORED TO SIZE AFTER THEY HAVE BEEN PRESSED INTO THE IMPELLER. BORE TO .379/.381 INCHES I.D. THE CARBON AND CERAMIC BUSHINGS ARE TO FINISHED SIZE AND DO NOT REQUIRE BORING AFTER ASSEMBLY.

REPAIR PARTS LIST			
ITEM	DESCRIPTION	QTY.	PART NO.
1	Motor, Drip Proof, 115/230 Volt, 1 Phase, ½ H.P.	1	0153-0027-1000
1	Motor, Totally Enc., 115/230 Volt, 1 Phase, ½ H.P.	1	0153-0019-1000
2	5/8 O.D. Stainless Bracket Washer	4	0155-0019-1000
3	3/8 Stainless Hex. Bracket Screw	4	0155-0017-1000
4	Motor-Pump Connecting Bracket (Ryton)	1	0153-0001-0100
5	Drive Magnet Assembly	1	0153-0035-0100
6A	Impeller Magnet Housing w/Rear Thrust Washer (Ryton)	1	0153-0005-0100
6B	Impeller Magnet Housing w/Rear Thrust Washer (Kynar)	1	0153-0041-0100
7A	Impeller Magnet Ass'y. w/Ryton Bushing (Polypropylene)	1	0153-0003-0400
7B	Impeller Magnet Ass'y. w/Carbon Bushing (Kynar)	1	0153-0043-0500
8	Ceramic Thrust Washer	1	0155-0009-1000
9	Ceramic Spindle	1	0153-0007-1000
10	4-7/16 O.D. "O" Ring (Viton)	1	0153-0015-1000
11A	Pump Housing (Ryton)	1	0153-0002-1000
11B	Pump Housing (Kynar)	1	0153-0042-1000
12	½ O.D. Housing Stainless Washer	6	0155-0021-1000
13	¼ Stainless Hex. Housing Screw	6	0153-0011-1000

Contact factory for other materials and/or parts not listed.

### LIMITED WARRANTY

March pumps are guaranteed only against defects in workmanship or materials for a period of one year from date of manufacture pumping water. On all other solutions, contact the factory for application assistance. March Pump Application Worksheet 750-130-10 is available for additional warranty information.