



Franklin Electric Co., Inc.
P. O. Box 12010
Oklahoma City, OK 73157-2010
405.947.2511 • Fax: 405.947.8720
www.LittleGiantPump.com
CustomerService-WTS@fele.com

B-180 THROUGH B-500 SERIES

INTRODUCTION

This instruction sheet provides you with the information required to safely own and operate your product. Retain these instructions for future reference.

The product you have purchased is of the highest quality workmanship and material, and has been engineered to give you long and reliable service. These products are carefully tested, inspected, and packaged to ensure safe delivery and operation. Please examine your item(s) carefully to ensure that no damage occurred during shipment. If damage has occurred, please contact the place of purchase. They will assist you in replacement or repair, if required.

READ THESE INSTRUCTIONS CAREFULLY BEFORE ATTEMPTING TO INSTALL, OPERATE, OR SERVICE YOUR LITTLE GIANT PRODUCT. KNOW THE PRODUCT'S APPLICATION, LIMITATIONS, AND POTENTIAL HAZARDS. PROTECT YOURSELF AND OTHERS BY OBSERVING ALL SAFETY INFORMATION. FAILURE TO COMPLY WITH THESE INSTRUCTIONS COULD RESULT IN PERSONAL INJURY AND/OR PROPERTY DAMAGE!

SAFETY GUIDELINES



Disconnect the pump from the power source before servicing or removing any component.

Do not use to pump flammable or explosive fluids such as gasoline, fuel oil, kerosene, etc. Do not use in explosive atmospheres. Pump should only be used with liquids compatible with pump component materials.

Do not handle pump with wet hands or when standing on a wet or damp surface or in water.

This pump is supplied with a grounding conductor and/or grounding type attachment plug. To reduce the risk of electric shock, be certain that it is connected to a properly grounded grounding type receptacle.

In any installation where property damage and/or personal injury might result from an inoperative or leaking pump due to power outages, discharge line blockage, or any other reason, a backup system(s) and/or alarm should be used.

Support pump and piping when assembling and when installed. Failure to do so may cause piping to break, pump to fall, motor bearing failures, etc.

If pump is oil-filled, the motor housing is filled with a dielectric lubricant at the factory for optimum motor heat transfer and lifetime lubrication of the bearings. Use of any other lubricant could cause damage and void the warranty. This lubricant is non-toxic; however, if it escapes the motor housing, it should be removed from the surface quickly by placing newspapers or other absorbent material on the water surface to soak it up, so aquatic life is undisturbed.

This pump has been tested using water only. The suitability of this pump for use with liquids other than water is the responsibility of the end-user.

This pump is not intended for permanent mounting to a building structure by bolting or similar means.

ELECTRICAL CONNECTIONS



1. Check the pump label for proper voltage required. Do not connect to voltage other than that shown.
2. If pump is supplied with a 3-prong electrical plug, the third prong is to ground the pump to prevent possible electrical shock hazard. **DO NOT REMOVE** the third prong from the plug. A separate branch circuit is recommended. Do not use an extension cord. Do not cut plug from the cord. If the plug is cut or the cord is shortened, then this action will void the warranty.
3. If the cord is equipped with stripped lead wires, such as on 230v models, be sure that the lead wires are connected to a power source correctly. The green/yellow wire is the ground, and the blue (or white) and the brown (or black) are live.
4. All wiring should be performed by a qualified electrician.
5. **DO NOT** use sheet metal screws to secure the equipment grounding conductor.

CONSULT INSTRUCTION SHEET ILLUSTRATIONS FOR PROPER ASSEMBLY AND DISASSEMBLY OF YOUR PUMP.

OPERATION

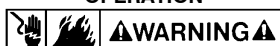

1. This pump is designed to operate submerged or in-line. It can be placed in any position, but preferably the volute should be located to the side.

2. If the surface is dirt or sand, place pump on a flat surface such as a piece of wood or metal to prevent it from being clogged.
3. The weight of the pump must be supported adequately. **DO NOT** support the pump by the intake or discharge connections alone.
4. Do not attempt to restrict the intake side of these pumps. Restricting the intake may cause damage to the seal and may starve the pump. If you require reduced flow rates, then place a valve on the discharge side of the pump or if flexible vinyl tubing is used, a clamp can be used on the tubing to restrict the flow.
5. Do not let the pump operate dry. It is designed to be cooled by pumping fluid. You may damage the seal and the motor may fail if the pump is allowed to run dry.
6. If the pump is going to be idle for an extended period, follow the cleaning instructions outlined in the next section. Do not let the pump freeze in the wintertime. This may cause cracking or distortion that may destroy the pump.
7. If fused type plug is used on 230V units, a 2.0 amp fuse is recommended.

MAINTENANCE



DISCONNECT THE PUMP FROM THE POWER SOURCE BEFORE SERVICING OR REMOVING ANY COMPONENT!

1. This pump is permanently lubricated. Oiling is not required. **DO NOT** open the sealed portion of the pump or remove housing screws. The power cord cannot be replaced. In case of damage the entire pump must be replaced.
2. Periodic cleaning of the pump parts will prolong the life and efficiency of the pump. Refer to the assembly and disassembly of the pumping head.
3. First remove the intake screen from the pump. Then remove the volute mounting screws. (**DO NOT** remove any other screws.)
4. Lightly clean any corrosion or debris which may clog the impeller. Use a brush and penetrating oil and lightly scrape to remove encrusted material.
5. Turn the impeller by hand to make sure it turns freely. Set pump down so the pump and impeller are not touching anything. Plug the unit into GFCI circuit for 10 seconds to see if the impeller turns; a) If it is rotating and GFCI did not trip, unplug unit and install parts in reverse order in which they were removed. b) If it does not rotate, if pump is tripping circuit breakers, or not operating properly after cleaning, return to Proven Pump or its authorized service center. **DO NOT** attempt repairs yourself.
6. Be certain power cord is in good condition and contains no nicks or cuts.
7. The motor is a continuous-duty type, sealed in oil with an automatic thermal overload protector device.

WARNING: THE PUMP MOTOR IS EQUIPPED WITH AN AUTOMATIC RESETTING THERMAL PROTECTOR AND MAY RESTART UNEXPECTEDLY. PROTECTOR TRIPPING IS AN INDICATION OF MOTOR OVERLOADING AS A RESULT OF OPERATING THE PUMP AT LOW HEADS (LOW DISCHARGE RESTRICTION), EXCESSIVELY HIGH OR LOW VOLTAGE, INADEQUATE WIRING, INCORRECT MOTOR CONNECTIONS, OR A DEFECTIVE MOTOR OR PUMP.

8. The pump can run against a restricted discharge such as a fountain without damage to the pump.

PUMP SERIES	REPAIR KIT	IMPELLER SPACING	DESCRIPTION
B-180	556704	.125"	Repair kit contains screen, screws, volute, gasket, and impeller.
B-240 B-300	556706	.045"	
B-500	556705	.145"	

Figure 1

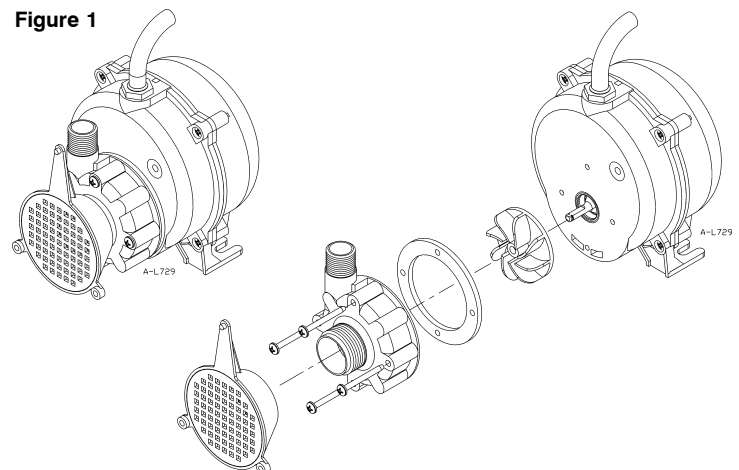

TROUBLESHOOTING

PROBLEM	PROBABLE CAUSES	CORRECTIVE ACTION
Pump fails to run.	No electricity or low voltage.	Be sure correct voltage is available.
	Impeller clogged.	Clean impeller.
	Motor has open circuit.	Replace pump.
Pump runs but no fluid flows.	Discharge height too great.	Lower the height.
	Inlet screen clogged.	Clean or replace.
	Discharge valve closed.	Open the valve.
	Air trapped in pump.	Purge to eliminate air.
	No water in reservoir.	Refill.
	Pump inlet located above liquid level.	Pump inlet must be below liquid level (flooded).
Flow rate is low.	Low voltage.	Be sure correct voltage is available.
	Impeller clogged.	Clean impeller.
	Inlet or discharge plumbing restricted.	Clean plumbing.
	Discharge plumbing undersized.	Replace with larger plumbing.
	Discharge height too great.	Lower the height.
Pump starts and stops pumping.	Impeller or inlet screen clogged.	Clean impeller and screen.
	Defect in motor.	Replace pump.
	Incorrect voltage or frequency.	Be sure correct voltage and frequency is supplied to pump.

LIMITED WARRANTY

Your product is guaranteed to be in perfect condition when it leaves our factory. It is warranted against defective materials and workmanship for a period of 12 months from date of purchase by the user.

Any product that should fail for either of the above two reasons and is still within the warranty period will be repaired or replaced at the option of Little Giant Pump Company, Inc. dba Franklin Electric Water Transfer Systems (hereafter "the manufacturer") as the sole remedy of buyer. For our customers in the continental United States: Please return the defective product, postage paid, to the factory at 301 North MacArthur Blvd., Oklahoma City, OK 73127-6616. All defective products returned under warranty will be fully inspected to determine the cause of failure before warranty is approved.

For our customers located elsewhere: It is not economical, due to duties and freight, to return the product to the factory for inspection. Please return the defective product to any authorized distributor or dealer with a brief written explanation of the problem. If there are no apparent signs of customer abuse, the product will be repaired or replaced. If dispute arises over replacement of the product, the distributor or dealer is to segregate such items and hold for inspection by a representative of the manufacturer or notify factory with details of the problem for factory disposition and settlement of warranty claim.

DISCLAIMER: THE FOREGOING WARRANTY IS AN EXCLUSIVE WARRANTY IN LIEU OF ANY OTHER EXPRESS WARRANTIES. ANY IMPLIED WARRANTIES (INCLUDING, BUT NOT LIMITED TO ANY IMPLIED WARRANTY OF MERCHANTABILITY OR FITNESS FOR A PARTICULAR PURPOSE) TO THE EXTENT EITHER APPLIES TO A PRODUCT SHALL BE LIMITED IN DURATION TO THE PERIODS OF THE EXPRESS WARRANTIES GIVEN ABOVE.

Warranty will be **VOID** if any of the following conditions are found:

1. Sealed motor housing opened.
2. Product connected to voltage other than indicated on nameplate.
3. Cord cut off to a length less than three feet.

4. Pump allowed to operate dry (fluid supply cut off).
5. Pump used to circulate anything other than fresh water, light oils, or other mild liquids at approximately room temperature.
6. Product abuse by customer.

Any oral statements about the product made by the seller, the manufacturer, the representatives or any other parties, do not constitute warranties, shall not be relied upon by the user, and are not part of the contract for sale. Seller's and manufacturer's only obligation, and buyer's only remedy, shall be the replacement and/or repair by the manufacturer of the product as described above. **NEITHER SELLER NOR THE MANUFACTURER SHALL BE LIABLE FOR ANY INJURY, LOSS OR DAMAGE, DIRECT, INCIDENTAL OR CONSEQUENTIAL (INCLUDING, BUT NOT LIMITED TO INCIDENTAL OR CONSEQUENTIAL DAMAGES FOR LOST PROFITS, LOST SALES, INJURY TO PERSON OR PROPERTY, OR ANY OTHER INCIDENTAL OR CONSEQUENTIAL LOSS), ARISING OUT OF THE USE OR THE INABILITY TO USE THE PRODUCT AND THE USER AGREES THAT NO OTHER REMEDY SHALL BE AVAILABLE TO IT.** Before using, the user shall determine the suitability of the product for the intended use, and user assumes all risk and liability whatsoever in connection therewith.

Some states and countries do not allow limitations on how long an implied warranty lasts or the exclusion or limitation of incidental or consequential damages, so the above limitations or exclusions may not apply to you. This warranty gives you specific legal rights, and you may also have other rights which vary from state to state and country to country.

The National Electric Code (in the USA) and similar codes in other countries require a Ground Fault Circuit Interrupter (GFCI) to be installed in the branch circuit supplying fountain equipment rated above 15 volts. We recommend each pump be used with a GFCI.

For parts or repair, please contact 1.888.572.9933
 For technical assistance, please contact 1.888.956.0000

www.LittleGiantPump.com
 CustomerService-WTS@fele.com