

# Little GIANT®

Little Giant  
P. O. Box 12010  
Oklahoma City, OK 73157-2010  
405.947.2511 • Fax: 405.947.8720  
www.LittleGiantPump.com  
CustomerService-WTS@fele.com

## 35-OM HIGH PRESSURE PUMP

### INTRODUCTION

This instruction sheet provides you with the information required to safely own and operate your Little Giant pump. Retain these instructions for future reference.

The Little Giant pump you have purchased is of the highest quality workmanship and material, and has been engineered to give you long and reliable service. Little Giant pumps are carefully tested, inspected, and packaged to ensure safe delivery and operation. Please examine your pump carefully to ensure that no damage occurred during shipment. If damage has occurred, please contact the place of purchase. They will assist you in replacement or repair, if required.

**READ THESE INSTRUCTIONS CAREFULLY BEFORE ATTEMPTING TO INSTALL, OPERATE, OR SERVICE YOUR LITTLE GIANT PUMP. KNOW THE PUMP'S APPLICATION, LIMITATIONS, AND POTENTIAL HAZARDS. PROTECT YOURSELF AND OTHERS BY OBSERVING ALL SAFETY INFORMATION. FAILURE TO COMPLY WITH THESE INSTRUCTIONS COULD RESULT IN PERSONAL INJURY AND/OR PROPERTY DAMAGE!**

### DESCRIPTION

The 35-OM is a non-submersible, high-pressure pump capable of pumping mild detergents. It is designed for use in carpet cleaners, pressure washers, dispenser displays, etc. It uses a glass-filled, nylon pumping head and glass-filled Ryton® impeller. It has a 3/8" O.D. barbed intake and discharge, 1/8" barbed bypass port, a carbon/ceramic mechanical face seal for long seal life, BUNA-N O-ring, and a double insulated, universal-type, series wound motor.

### SAFETY GUIDELINES



- CAUTION: To reduce the risk of electrical shock, disconnect pump from power source before servicing.**
- Read all instructions and safety guidelines thoroughly. Failure to follow the guidelines and instructions could result in serious bodily injury and/or property damage.
- Do not pump flammable liquids such as gasoline or fuel oil.
- During operation, the area surrounding the pump may be covered with water. Take care when handling the pump. Do not disconnect the plumbing connections when pump is in operation.
- Do not stand in water when changing fuses.

### INSTALLATION

Your pump is delivered completely pre-assembled and pretested from the factory. It is ready for immediate use. The pump may be installed in any position. It may be mounted vertically with the pump head down. Proper plumbing connections should be made, see specifications.

Motor nameplate lists all electrical data. Make sure the pump is connected to proper voltage before operating.

Do not allow pump to run dry. These pumps are not submersible, operate the pumps only in the in-line mode. Do not put the units in liquid. Pump should be installed in a dry area and protected from splash. These pumps are not self priming models; they must be installed so that the pump head (volute) is flooded at the time the pump is to be started. That is, the inlet of the pump must be below the level of the surface of the liquid being pumped (Figure 1).

Do not restrict the intake side of the pump. Connections on the intake side should not be of smaller inside diameter hose than the intake

Figure 1

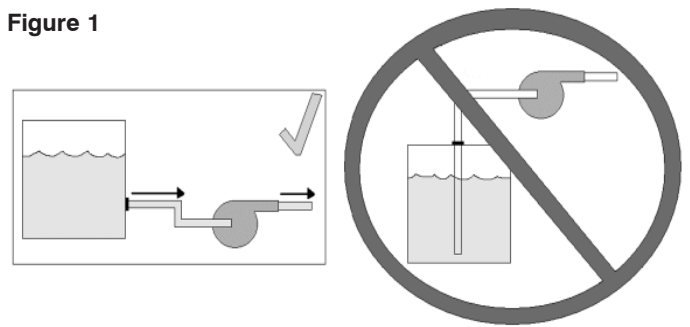

inside diameter. If reduced flow is required, restrict the discharge side. Installing a valve or other type of restriction device on the discharge side is the proper method for reducing flow from the pump. When using a valve, the pump can be throttled to provide various flow rates and pressures without harming the motor or the pump parts.

Use the bypass port for applications that have priming problems, closed discharge or dead head. Under dead head conditions, without bypass, the high RPM of the impeller (approximately 9000 RPM) will cause liquid to heat and vaporize. This results in the pump running dry and seal failure.

### SPECIFICATIONS

<b>Volts</b>	<b>115</b>	<b>220/240</b>
<b>Horsepower</b>	1/11	1/12
<b>RPM</b>	9000	8000
<b>Amps</b>	1.25	.6
<b>Intake Size</b>	3/8" O.D., barbed	
<b>Discharge Size</b>	3/8" O.D., barbed	
<b>Pump Dimensions</b>	Width: 4" Length: 6.9" Height: 2.93"	
<b>Pump Weight</b>	2.5 lbs. (net) 2.7 lbs. (gross)	
<b>Motor Life</b>	Brush life - 500 hours	
<b>Motor Type</b>	Open air series Wound-brush type, double insulated	

Figure 2

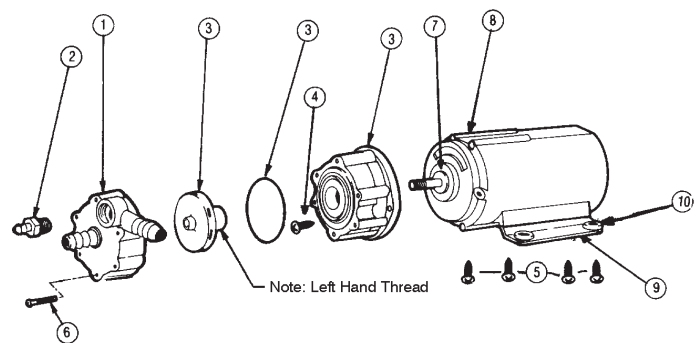

Item	Part No.	Description	Qty.	Catalog No.	
				532002	532012
1	132101	Volute	1	x	x
2	941034	Bypass adaptor	1	x	x
3	599106	Seal kit	1	x	x
4	902326	Screw	2	x	x
5	902325	Screw	4	x	x
6	902318	Screw	6	x	x
7	921040	Slinger	1	x	x
8	979506	Motor, 115V	1	x	
8	979606	Motor, 230V	1		x
9	132005	Base	1	x	x
10	925008	Grommet	4	x	x

532002 or 532022					35-OM	115V
GALLONS PER HOUR					Shut Off	PSI
10'	20'	30'	50'	70'		
170	155	140	110	60	87	37.7
with bypass:						
165	150	135	100	50	81	35.0

532012					35-OM	220/240V
GALLONS PER HOUR					Shut Off	PSI
10'	20'	30'	50'	70'		
160	150	130	95	40	80	34.7
with bypass:						
155	145	125	85	30	74	32.0

PUMP – TROUBLESHOOTING INFORMATION	
PROBLEM	CHECK
1. No fluid being pumped.	1. No fluid in supply tank.
	2. Air trapped in volute – turn pump off and bleed air through discharge hose by opening valve and slightly tilting unit to allow air to escape through discharge or by-pass (air will go up), if open passage is provided and pump is off.
	3. Clogged intake of discharge tubing.
	4. Is motor operating; if not, go to section on motor trouble shooting.
	5. Check impeller and pump volute for clogging; clean if necessary.
2. Seal Leaking 2.1 Seal, carbon face 2.2 Seal, ceramic face 2.3 No spring tension in carbon seat assembly	If leak appears to be around shaft, disconnect power and remove impeller.
	Examine carbon face for breaks in the surface or foreign particles present to cause leaks. If carbon has chips or cracks, seal housing assembly must be replaced. If foreign particles are present, use lens tissue to clean surface. Surface must be clean, free of particles, fingerprints and chips, or it must be replaced.
	A continuous carbon track must be present (black ring). If trash causes a break in the tracking, then clean ceramic with water; lens tissue should be used to avoid scratching. Surface must be clean and free of all debris, fingerprints, scratches and cracks.
	Loss of spring tension generally is a result of the rubber diaphragm inside the seal becoming hard and not allowing spring to function. Seal/housing assembly must be replaced.
3. Leakage of O-ring seal	If O-ring becomes twisted in assembly it will leak; or if debris is in the gland, the O-ring will not seal properly. Apply vaseline to O-ring. This method will aid in proper installation of O-ring.
4. Cracked ceramic or carbon face bonded to ceramic.	Pump was allowed to run dry and then water was added, resulting in thermal shock to ceramic causing it to crack. Replace both carbon and ceramic seal (housing and impeller).
5. Melted impeller hub	Pump allowed to operate dry or pump head not properly aligned, allowing impeller to rub on brass/carbon portion of seal in the housing. Replace both impeller/ceramic assembly and housing/carbon assembly. Check for proper alignment.
MOTOR – TROUBLESHOOTING INFORMATION	
1. Motor problem – does not run	Check wiring of motor and switches; replace motor.
2. Excessive arcing	Brushes on new motor have not seated. Let motor operate for 3 minutes. Do not run pump dry (without fluid). Run motor again. If arcing continues, replace motor.

**LITTLE GIANT WARRANTY STATEMENT**

Your Little Giant product is guaranteed to be in perfect condition when it leaves our Factory. It is warranted against defective materials and workmanship for a period of 12 months (90 day warranty on Models: 1-AA-OM, GKPK-SC, PP-1, PPS-1, PP-12, PPS-12, PP-230 and Cooler King) from date of purchase by the user. No warranty on brush wear in Model 35-OM and impeller or cam in Models PP-1, PP-12, and PP-230. Any product that should fail for either of the above two reasons and is still within the warranty period will be repaired or replaced if returned prepaid to our Factory. All defective products returned under warranty will be fully inspected to determine "cause of failure" before warranty is approved. Little Giant will honor the warranty within the warranty time period specified on satisfactory written proof of purchase.

**DISCLAIMER:** Any oral statements about the product made by the seller, the manufacturer, the representatives or any other parties, do not constitute warranties, shall not be relied upon by the user and are not part of the contract for sale. Sellers and manufacturers only obligation, and buyers only remedy, shall be the replacement and/or repair by the manufacturer of the product as described above. NEITHER SELLER NOR THE MANUFACTURER SHALL BE LIABLE FOR ANY INJURY, LOSS OR DAMAGE, DIRECT, INCIDENTAL OR CONSEQUENTIAL (INCLUDING, BUT NOT LIMITED TO INCIDENTAL OR CONSEQUENTIAL DAMAGES FOR LOST PROFITS, LOST SALES, INJURY TO PERSON OR PROPERTY, OR ANY OTHER INCIDENTAL OR CONSEQUENTIAL LOSS), ARISING OUT OF THE USE OR THE INABILITY TO USE THE PRODUCT AND THE USER AGREES THAT NO OTHER REMEDY SHALL BE AVAILABLE TO IT. Before using, the user shall determine the suitability of the product for the intended use, and user assumes all risk and liability whatsoever in connection therewith. The warranty and remedy described in this limited warranty is an EXCLUSIVE warranty and remedy and is IN LIEU OF any other warranty or remedy, expressed or implied, which other warranties and remedies are hereby expressly EXCLUDED, including but not limited to any implied warranty

of MERCHANTABILITY OR FITNESS FOR A PARTICULAR PURPOSE. Some states do not allow the exclusive or limitation of incidental or consequential damages, so the above limitation or exclusion may not apply to you. This warranty gives you specific legal rights, and you may also have other rights which vary from state to state.

Warranty will be VOID if any of the following conditions are found:

1. Sealed motor housing opened.
2. Product connected to voltage other than indicated on name plate.
3. Cord cut off to a length less than three feet.
4. Pump allowed to operate dry (fluid supply cut off).
5. Pump used to circulate anything other than fresh water, light oils, or other mild liquids at approximately room temperature.
6. Product abuse by customer.

The National Electric Code requires a Ground Fault Circuit Interrupter (GFCI) be installed in the branch circuit supplying fountain equipment rated above 15 volts. Little Giant Pump Company offers a variety of GFCI's and recommends each pump be used with a GFCI.

**For parts or repair, please contact . . . . . 1.888.572.9933**  
**For technical assistance, please contact . . . . . 1.888.956.0000**

**www.LittleGiantPump.com**  
**CustomerService-WTS@fele.com**