

Little GIANT Pump Company

20G SERIES GRINDER



Features

- Powerful 2HP, 3450 RPM, capacitor start, capacitor run* thermally protected motor to handle the demands of grinding domestic sewage.
- Oil-filled motor features upper and lower ball bearings, permanently lubricated, for years of smooth, dependable operation.
- Rugged cast-iron motor housing and volute are epoxy coated for corrosion resistance and durability
- Stainless steel cutter assembly designed to reduce solids to a slurry, for pumping through smaller diameter pipe than other types of systems
- 20G maximum head 55 feet
- 20GH maximum head 110 feet
- Maximum flow 65 GPM
- Available in 200-208 or 230 volts, single phase
- Heavy duty 15' power cord
- Every unit is thoroughly tested before it ships from Little Giant Pump Company
- Complete, easy to install package systems available for ease of specifying and ordering

The “Magnum” Grinder Series 20G and 20GH have an exclusive cutter assembly that cuts sewage and stringy materials into tiny particles, eliminating roping and clogging that may occur in other pumps, producing a fine slurry that passes easily through the system. Compared to standard sewage pumps, this allows use of smaller diameter discharge pipes, smaller pumps, and less electricity, reducing installation and operating costs.

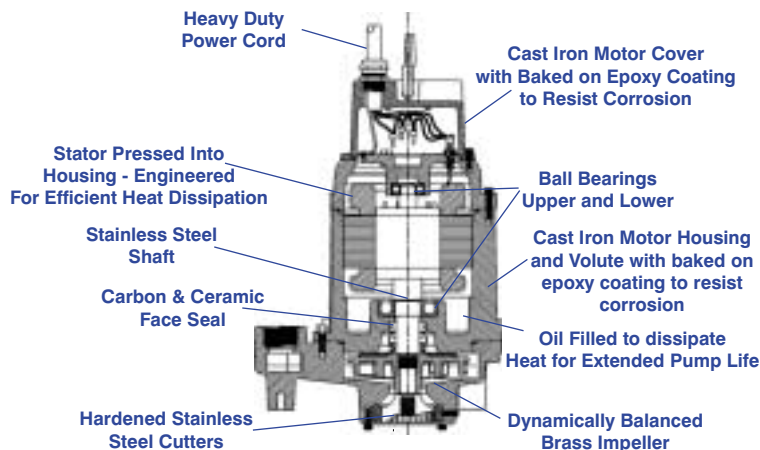

Because the 20G and 20GH do not need to pass large solids, they can efficiently pump a greater distance in terms of the total dynamic head (TDH), a combination of the static (vertical) lift and the horizontal run of discharge piping, while maintaining the necessary flow rate to scour the discharge pipe to prevent clogging.

*The 20G and 20GH require a specific control panel or capacitor kit from Little Giant Pump Company matched to the pump for safe operation and third party approval.

Little Giant Pump Co.

20G SERIES GRINDER

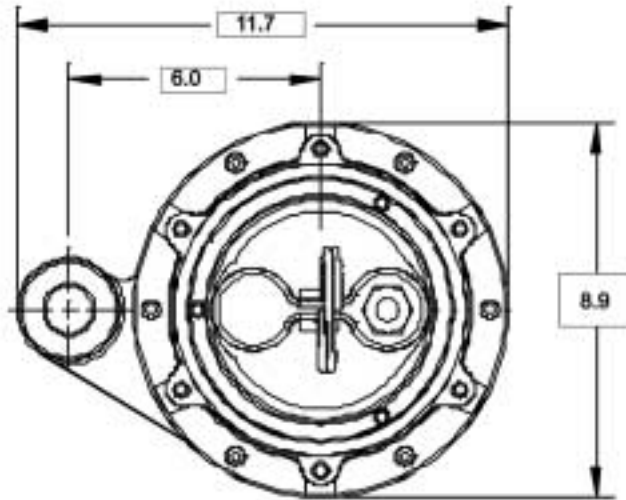
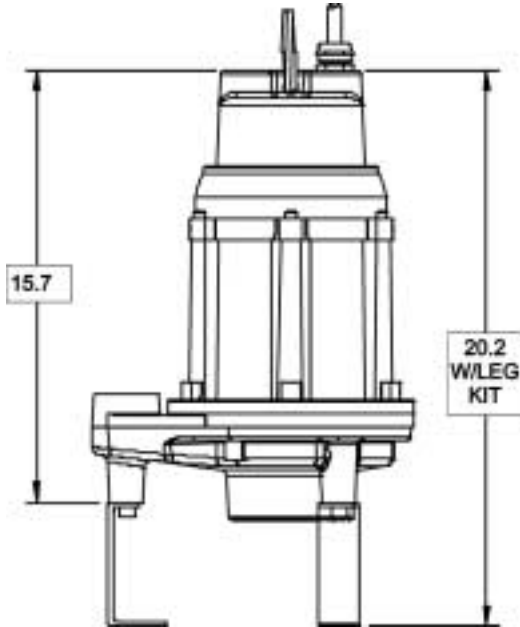

Specifications

MODEL NO.	ITEM NO.	LIFTING	HP	VOLTS	Hz	FULL LOAD AMPS/WATTS	PERFORMANCE (GPM@HEAD)						SHUTOFF	P.S.I.	WEIGHT (lbs.)
							20'	40'	60'	80'	100'	110'			
20G-CIM	520500	UL/CSA	2	230	60	12/2530	52	32	—	—	—	—	55	24	112
20G-CIM	520525	UL/CSA	2	200-208	60	13.5/2660	52	32	—	—	—	—	55	24	113
20GH-CIM	520600	UL/CSA	2	230	60	18/4060	—	—	60	45	25	—	110'	47.6	112
20GH-CIM	520625	UL/CSA	2	200-208	60	20.0/4045	—	—	60	45	25	—	110'	47.6	113

* 15' Power cord on all models

* The 20G and 20 GH require a specific control panel or capacitor kit from Little Giant Pump Company matched to the pump for proper operation and third party approval

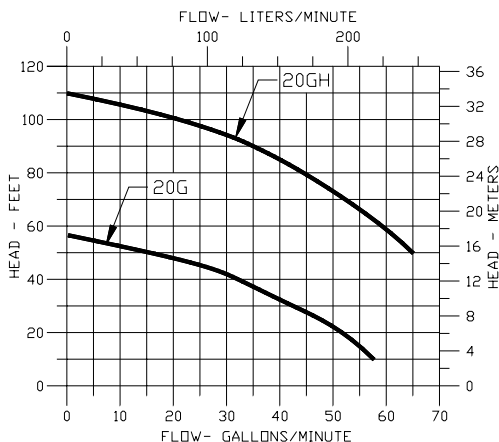

PUMP PERFORMANCE CURVE
20G & GH SERIES CATALOG 995583

Construction

Motor Housing	Epoxy-Coated Cast Iron
Impeller	Bronze Vortex
Volute	Epoxy-Coated Cast Iron
Power Cord	12/4 SOW-A/SOW
Mechanical Shaft Seal	Carbon & Ceramic
Fasteners	Stainless Steel
Shaft	Stainless Steel
Bearings	Heavy duty continuously oil-lubricated upper and lower ball bearings
Cutter System	440C Hardened Stainless Steel radial cutter and cutter ring
Discharge Size	1 1/4" FNPT

For technical advice or service please take your pump into your local pump service center.
To order pump or parts or for pricing please go to the following links :

[Little Giant Pumps Home >>](#)

[Little Giant Pumps stock list >>](#)