



Model 61050-1224
155 SL

REMOTE CONTROL
SEARCHLIGHT
FEATURES

- Constructed of noncorrosive materials
- Sealed beam halogen lamp
- Long life gear drive
- Low amp draw
- Patented clutch mechanism prevents motor damage when running against limit stops
- Remote control and 15' cable included
- Single lever or touch-pad control for vertical and horizontal light movement
- Two speed light movement
- Auto-sweep mode cycles light side-to-side automatically
- Light will transmit an "SOS" distress signal automatically

APPLICATION

Ideal for boaters ... locate buoys, moorings, channel markers, etc. Ideal for RV'ers ... pinpoint road signs, campsites, or use as backup light.

SPECIFICATIONS

- 360° horizontal movement
- 75° vertical sweep
- White thermoplastic housing and base

INSTALLATION INSTRUCTIONS

LIGHT MOUNTING

1. Select a location for the light which will allow for clear beam projection. Searchlight base should be mounted on level, flat surface.
2. Using the light base mounting template enclosed, drill three pilot holes and a cable exit hole. Fasten hold down bracket on to mounting surface with screws provided, or applicable screws for your application.
3. Peel off adhesive backing from gasket and place on light mounting base with the adhesive side on the base. Feed cable through cable exit hole.



Model 61050-1224

Electronic Control Unit

Control and 15' cable included with light

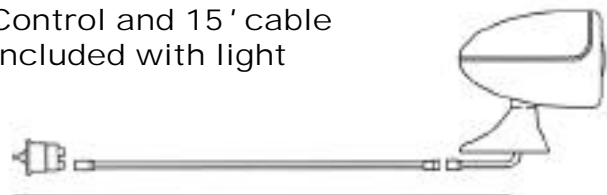

Dual station kit #64044-0000



4. Slide light base on to hold down bracket while pushing down on base, making sure metal strip on light base engages the hold down bracket. Fasten screw on the outside of the base to seal the base against the surface.

NOTE: Secure cable with nylon clips or equivalent. Protect installation at points of stress and leave adequate slack where cable must be flexible.

Model Number	Voltage	Amps	Fuse/Breaker	Candlepower	Weights lb (kg)	Standard Carton
61050-1224	12/24V DC	4.5	10	100,000	5 (2.3)	4

CONTROL MOUNTING

1. Select a location near the helm position to mount the control. Check under the mounting area to assure there is adequate clearance for the control.
2. Cut 2-3/4" (70mm) diameter hole for the control and drill two pilot holes for the mounting screws.
3. Power to control must be controlled by the boat running light switch. The searchlight control has LED illumination that will go on with the boat running lights. The searchlight can only be used with the running lights on. The running light circuit must be capable of carrying the amperage load in addition to the running lights and have a fuse or circuit breaker of appropriate size.
4. Connect the RED control power lead to the switched side of the running light circuit. Connect the BLACK control power lead to a battery negative source. DO NOT connect in reverse polarity, as control damage may result. Use 12–14 gauge wire to extend power leads if necessary.
5. Bring power leads and light cable through hole and plug into back of control.
6. To eliminate electrical interference produced by other electronic components on the boat that might affect the searchlight control, route the searchlight control cable to the light away from other components such as radios, GPS receivers and other navigation units.
7. Insert control with attached cables into hole and fasten with screws. A non-adhesive sealing compound should be used under the control mounting flange.
8. For joy-stick type of control, thread black lever into center hole. For touch-pad operation, insert black cap into threaded hole.

CLEANING OF EXTERIOR PLASTIC SURFACES

Recommendation for cleaning "Exterior Surfaces" is a solution of warm water and a mild detergent soap.

CAUTION Do not use cleaners that contain esters, halogenated solvents, aromatic solvents, ketones and strong acids or bases.

SERVICE

BULB REPLACEMENT

1. Remove light cover by removing screw from the rear of the light housing.
2. Pull the bulb assembly from the light housing and remove rubber seal around the bulb to separate the bulb from bulb housing.
3. Unscrew terminals from bulb and connect terminals to new bulb.
4. Replace seal ring and place bulb assembly in to the light housing. Fasten cover with screw.

LIGHT OPERATION

IMPORTANT — Do not shine the searchlight in any manner that will impair the vision of other boat operators.

The running light switch for the boat must be "on" for searchlight to operate. With the running light switch "on", the searchlight control will be illuminated.

SLOW — Press once to select slow light movement speed. Press again to turn light off.

FAST — Press once to select fast light movement speed. Press again to turn light off.

DIRECTIONAL MOVEMENT — The center lever is moved left, right, fore and aft to move light beam. If desired, the center lever can be unscrewed (counter-clockwise) and the black cap (supplied) can be pressed into the center hole. The light movement is then controlled by touching one of the four arrows.

AUTO SWEEP — With the light on, pushing this button will sweep the light in about a 90 degree arc automatically. This is useful in narrow canals and channels, freeing both hands for boat control. Press again to stop auto sweep.

SOS/DISTRESS — Press and hold for about five seconds to automatically flash "SOS" in International Morse Code. The light will sweep horizontally while flashing the SOS. Press again to stop the SOS flashing.

IMPORTANT — Do not allow anyone to "playfully" transmit the SOS signal! The SOS signal will not be transmitted with the boat's running lights "off".

CIRCUIT PROTECTION

The searchlight control has built-in circuit breaker protection for the searchlight. The breaker can be reset by turning the light on then off with the running lights on.

DUAL STATION CONTROL (OPTIONAL)

The optional Dual Station Control Kit #64044-0000 is used when an additional searchlight control location is desired.

1. Install control in the dual station kit as covered in the "Control Mounting" section of these instructions.
2. Using the 15' cable and Y adaptor included in the dual station kit, connect the cable into the light control cable.

Optional extension cables may be used where necessary to fit the application. Also, the 3 conductor cable may be cut and spliced together if too long.

PARTS LIST

Description	Part No.
Bulb Kit w/Seal Ring	18753-0528
Control (complete)	43690-1000
Dual Station Kit	64044-0000
15' Extension Cable	64042-1007
25' Extension Cable	64042-1008

MOUNTING TEMPLATE
(Light Base)

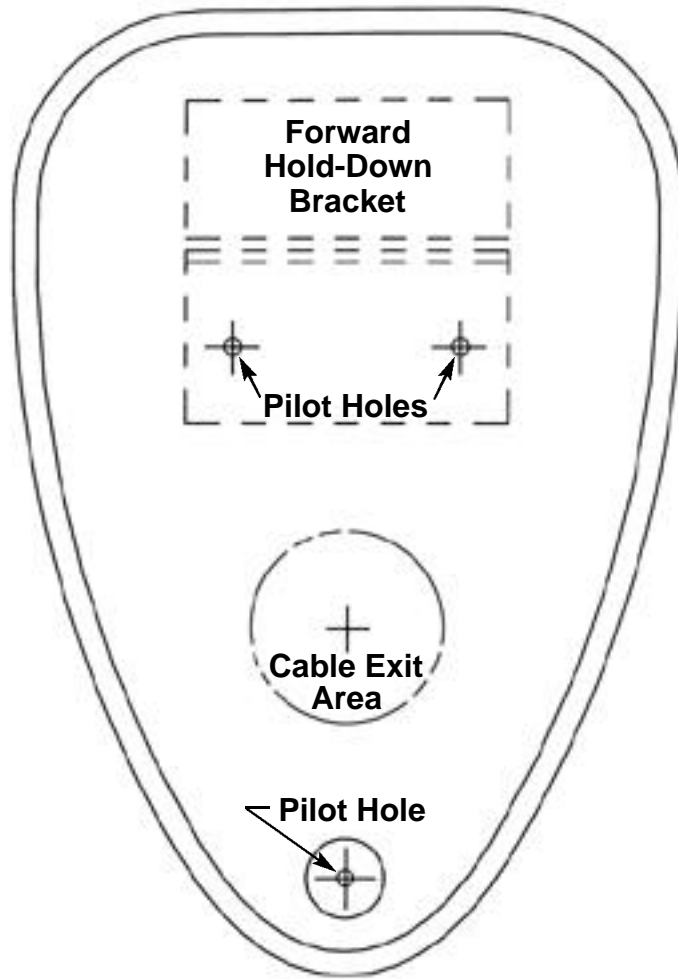

DIMENSIONAL DRAWING

Searchlight
Inches (Millimetres)

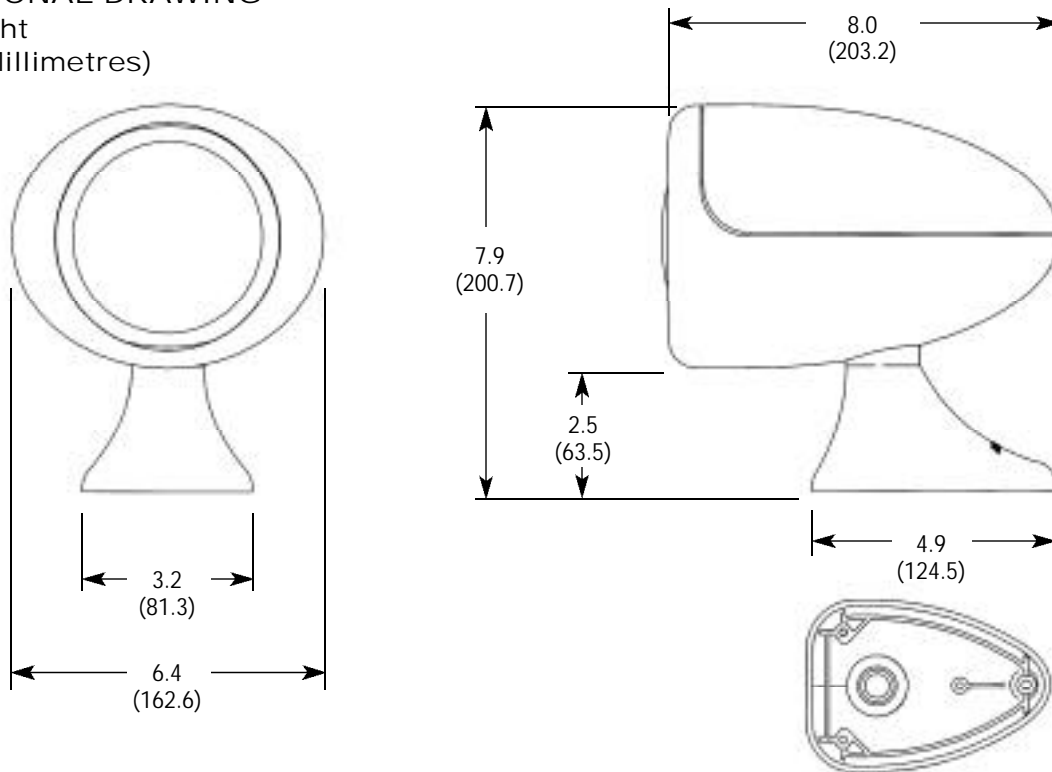

DIMENSIONAL DRAWING

Electronic Control Unit
Inches (Millimetres)

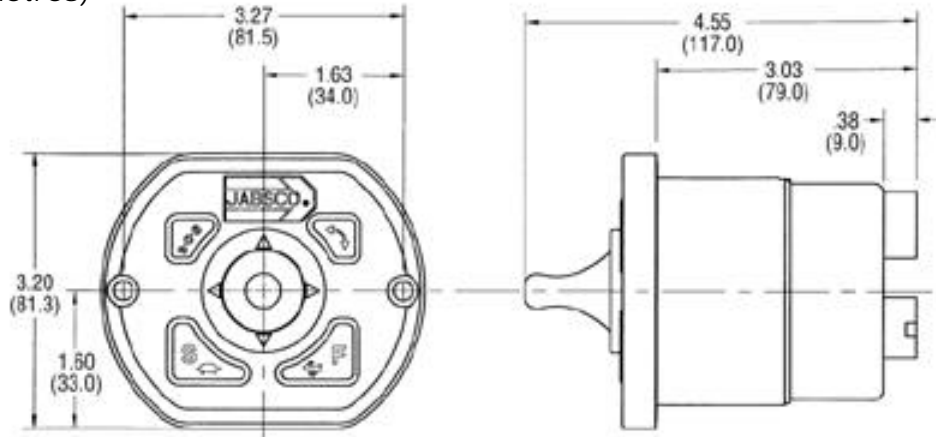

Mounting hole diameter 2.75" (70mm)

Jabsco



THE PRODUCTS DESCRIBED HEREIN ARE SUBJECT TO THE JABSCO ONE YEAR LIMITED WARRANTY, WHICH IS AVAILABLE FOR YOUR INSPECTION UPON REQUEST.

U.S.A.
 Jabsco
 20 Icon
 Foothill Ranch, CA 92610-3000
 Tel: 949.609.5106
 Fax: 949.859.1254

UNITED KINGDOM
 Jabsco
 Bingley Road, Hoddesdon
 Hertfordshire EN11 0BU
 Tel: +44 (0) 1992 450145
 Fax: +44 (0) 1992 467132

CANADA
 Fluid Products Canada
 55 Royal Road
 Guelph, Ontario N1H 1T1
 Tel: (519) 821.1900
 Fax: (519) 821.2569

JAPAN
 NHK Jabsco Company Ltd.
 3-21-10, Shin-Yokohama
 Kohoku-Ku, Yokohama, 222
 Tel: 045.475.8906
 Fax: 045.475.8908

GERMANY
 Jabsco GmbH
 Oststrasse 28
 22840 Norderstedt
 Tel: +49-40-53 53 73 -0
 Fax: +49-40-53 53 73 -11