



a xylem brand

## REMOTE CONTROL SEARCHLIGHT

### FEATURES

- Constructed of noncorrosive materials
- Sealed beam halogen lamp
- Remote control and 15' cable included
- Long life gear drive
- Low amp draw
- Patented clutch mechanism prevents motor damage when running against limit stops

### APPLICATION

Ideal for boaters...locate buoys, moorings, channel markers, etc. Ideal for RV'ers...pinpoint road signs, campsites, or use as backup light.

### SPECIFICATIONS

- 320° horizontal movement
- 75° vertical sweep
- 50 watt 3-1/2" x 6" bulb
- White thermoplastic housing and base

### INSTALLATION INSTRUCTIONS

#### LIGHT MOUNTING

Select a location for the light which will allow for clear beam projection forward and as far aft as possible. Searchlight base should be mounted on level, flat surface. Using the light base mounting template enclosed, drill three (3) mounting holes and a center hole at the center of base for wiring cable. Feed cable through hole and fasten light in place with three (3) #10 x 1" screws provided, or applicable screws for your particular application. Mount light so that the Jabco name on the base is facing to the rear.

NOTE: SECURE CABLE WITH NYLON CLIPS OR EQUIVALENT. PROTECT INSTALLATION AT POINTS OF STRESS, AND LEAVE ADEQUATE SLACK WHERE CABLE MUST BE FLEXIBLE.

**WARNING**



**Burn Hazard.**  
Do not touch lense when light is on. Do not operate with storage cover over light.



Remote Control Unit

Model 60020-Series

### CONTROL INSTALLATION (60030-0000)

Select a location near the helm which will allow for convenient operation of control.

1. Cut two holes (see Panel Cutout Template enclosed) for mounting control.
2. Route power leads (supplied by customer) from voltage source to control. Note: Wiring must be 16 gauge (minimum).
3. Connect positive (+) power lead to red (+) wire and negative (-) power lead to black wire using butt connectors.
4. Connect wires (matching colors) from control panel to end of light cable using butt connectors provided.
5. Use bedding compound or sealant to waterproof control mounting.
6. Secure control with self-tapping screws provided.

Model Number	Voltage	Amps	Candlepower	Weights lb (kg)	Standard Carton
60020-0000	12 Vdc	3.6	100,000	6 (2.7)	4
60020-0024	24 Vdc	2	100,000	6 (2.7)	4

## CONTROL UNIT OPERATION

### SWITCH FUNCTIONS

- (A) Light Switch – On/Off switch positions.
- (B) Directional Switch – Lever has eight contact positions and will operate in horizontal, vertical, and in four intermediate directions.

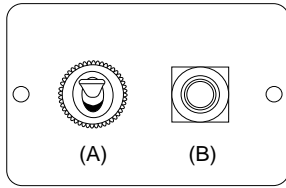

### CLEANING OF EXTERIOR PLASTIC SURFACES

Recommendation for cleaning “Exterior Surfaces” is a solution of warm water and a mild “dish washing” detergent soap.

**CAUTION** Do not use cleaners that contain esters, halogenated solvents, aromatic solvents, ketones and strong acids or bases.

### CIRCUIT PROTECTION

A 10 amp fuse is located in the On/Off toggle on control. To replace fuse grasp On/Off toggle and push in while turning to left facing control. Pull out fuse and replace. The proper fuse has been included in the fuse holder. Should this fuse blow, replace with the same size fuse after determining reason for blown fuse.

NOTE: ON SOME MODELS THE FUSE HOLDER MAY BE LOCATED SEPARATELY.

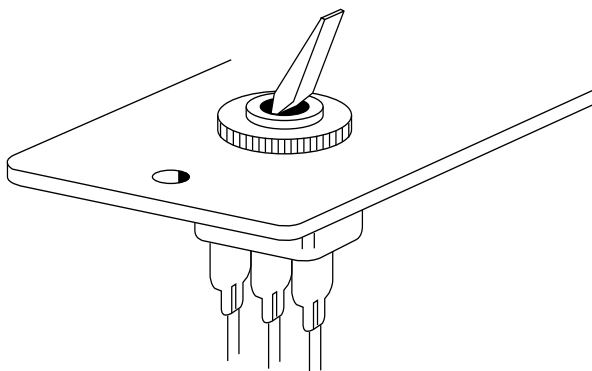

When installation and wiring is completed, check light operation. If light is inoperative, or does not operate correctly, refer to troubleshooting instruction.

## SERVICE

### CONTROL REPLACEMENT

Individual replacement parts are available for the control panel. To replace switches remove the two (2) screws from front of panel and pull forward, exposing wiring.

1. To remove directional switch push firmly on the front toggle and remove switch from back side of panel. Cut wires to the defective switch, and splice wires (with butt connectors) to the new switch, being sure

to match wire colors. Note: Install switch with yellow wire on top for correct directional aiming.

2. To remove On/Off fuse switch disconnect wires to defective switch and pull forward will gentle rocking motion from back side of panel easing switch out. Install new switch and secure using clip retainer on back side of control panel. Reconnect wiring terminals to switch.

### BULB REPLACEMENT

Remove four (4) screws and retaining bezel. Pull bulb assembly forward and disconnect spade connectors from back of bulb. Reconnect spade terminals to new bulb. Install bulb and fasten with bezel and four (4) screws.

### PARTS LIST

Description	Part Number
Bulb Kit	18753-0178
Directional Switch	43990-0000
On/Off Fuse Switch	18753-0180
Station Selector Switch	64073-0020
Control	60030-0000
12/24 Volt Converter	45969-1000
Upper Housing	60023-1000
Lower Housing	60024-1000
Base	60027-1000
Bulb Retainer	60035-1000
Motor-Vertical (upper)	18753-0458
Motor-Horizontal (lower)	18753-0350

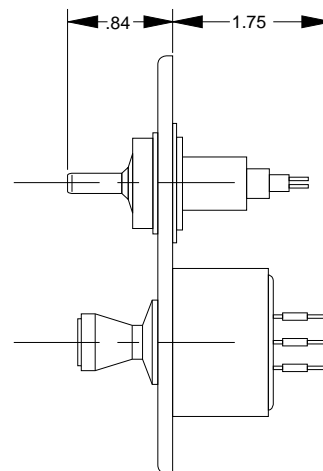
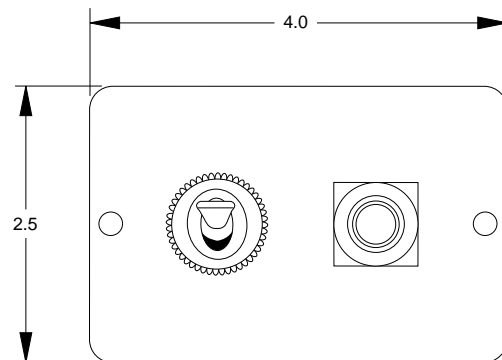

Note: Connect red and one black lead (16 gauges wire) from control to positive and negative leads from power source. Power leads to be 16 gauge minimum.

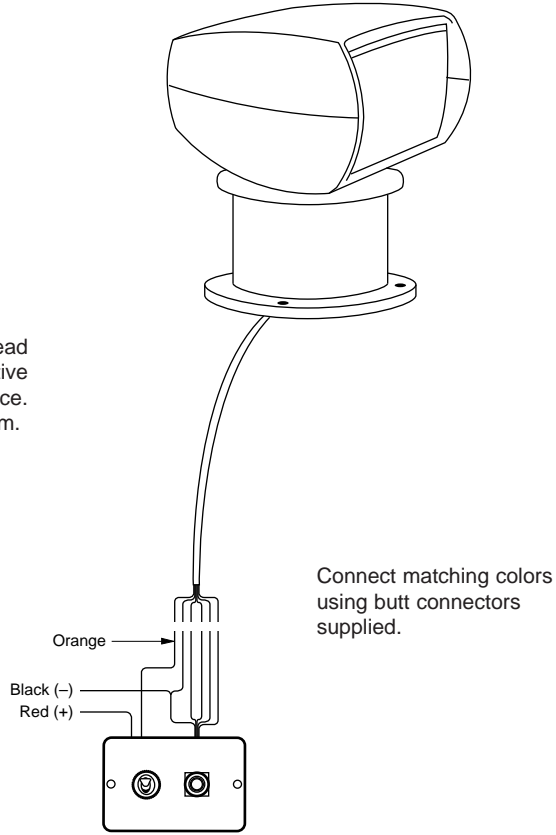

WIRING CODE	
← TO CONTROL	TO CABLE →
GRN	GRN
BRN	BRN
BLU	BLU
YEL	YEL
ORG	ORG
BLK	BLK
	GRY
NOT USED	

135 SL CONTROL FRONT VIEW

### DUAL STATION INSTALLATION KIT 43670-0005

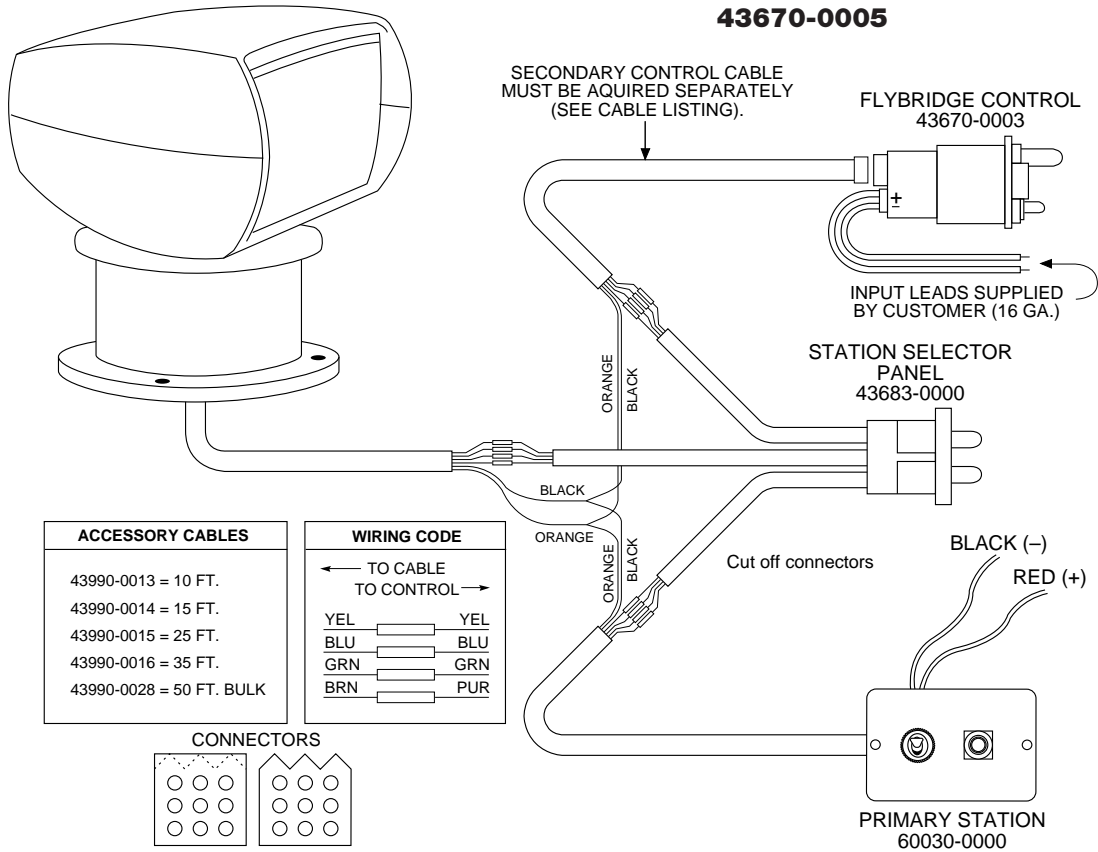

ACCESSORY CABLES
43990-0013 = 10 FT.
43990-0014 = 15 FT.
43990-0015 = 25 FT.
43990-0016 = 35 FT.
43990-0028 = 50 FT. BULK

WIRING CODE	
← TO CABLE	TO CONTROL →
YEL	YEL
BLU	BLU
GRN	GRN
BRN	PUR

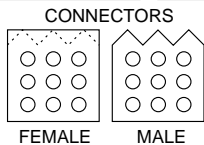

PRIMARY STATION  
60030-0000

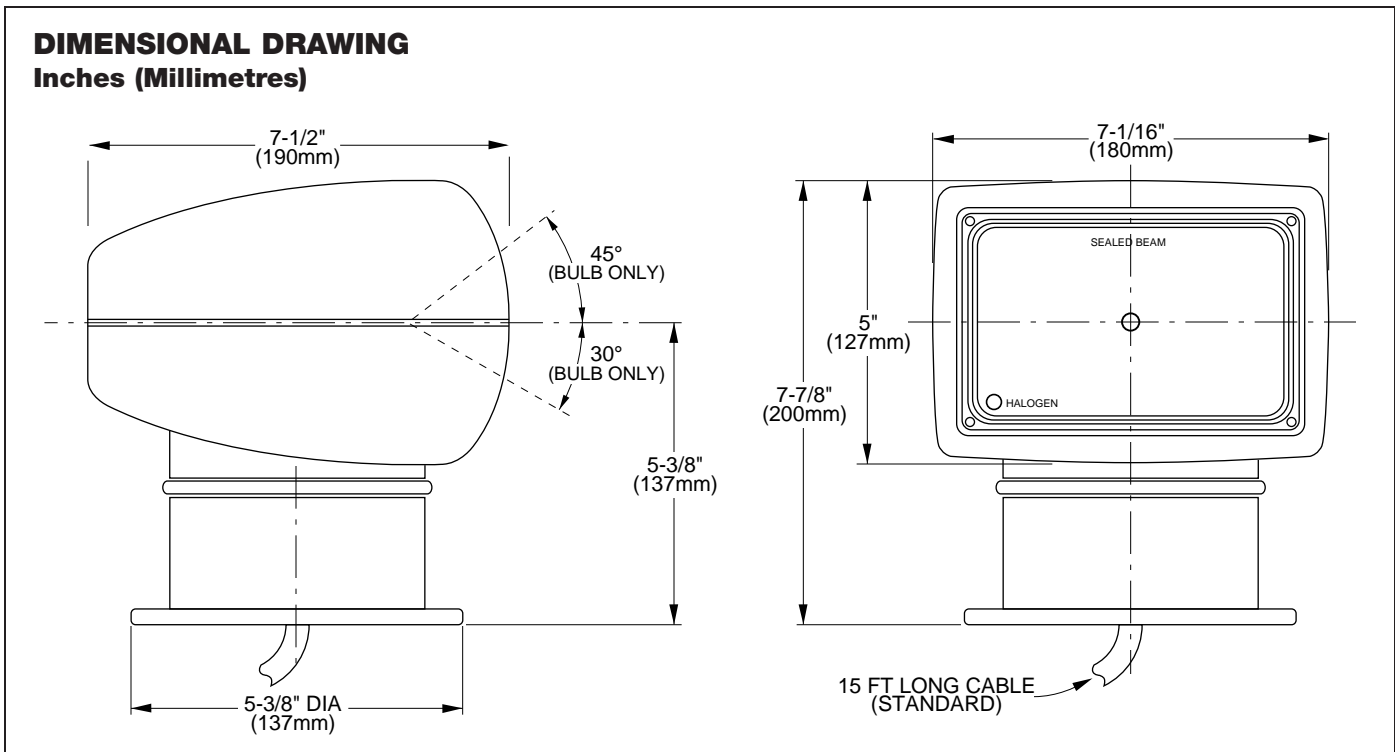

**TROUBLESHOOTING**

All lights are thoroughly inspected before shipping and are warranted to operate within specifications. If light does not operate correctly, check fuse and wire harness connections before proceeding.

<b>Problem</b>	<b>Solution</b>
Control works in reverse in all diections.	Control installed upside down.
Bulb operates – no light movement.	Check wiring code for proper wire color connections.
Light moves – bulb does not operate.	<ol style="list-style-type: none"> <li>1. Check bulb.</li> <li>2. Check wiring code for proper wire color connections.</li> </ol>
Dim light	<ol style="list-style-type: none"> <li>1. Check voltage at power source.</li> <li>2. Increase wire size from source to control.</li> <li>3. Check for proper ground circuit.</li> </ol>

THE PRODUCTS DESCRIBED HEREIN ARE SUBJECT TO THE JABSCO ONE YEAR LIMITED WARRANTY, WHICH IS AVAILABLE FOR YOUR INSPECTION UPON REQUEST.

www.xylemflowcontrol.com

Jabsco, 100 Cummings Center, Ste. 535-N, Beverly, MA 01915  
Tel: +1 978 281 0440 Fax: +1 978 283 2619

Jabsco, Bingley Road, Hoddesdon, Hertfordshire, EN11 0BU  
Tel: +44 (0) 1992 450 145 Fax: +44 (0) 1992 467 132

NHK Jabsco Co Ltd, 3-21-10, Shin - Yokohama Kohoku-ku, Yokohama 222  
Tel: +81 (0) 45 475 8906 Fax: +81 (0) 45 475 8908

Jabsco GmbH, Oststraße 28, 22844 Norderstedt  
Tel: +49 (0) 40 53 53 73 0 Fax: +49 (0) 49 53 53 73 11

Jabsco Italia, s.r.l., Via Tommaseo, 6, 20059 Vimercate, Milano  
Tel: +39 039 685 2323 Fax: +39 039 666 307

USA

UK

JAPAN

GERMANY

ITALY



a xylem brand

Jabsco Pumps 60020-0000

[www.PumpAgents.com](http://www.PumpAgents.com) - Click here for Pricing/Ordering for Pumps and Parts

