

Jabco Pumps 51580-2001
www.PumpAgents.com - Click here for Pricing/Ordering for Pumps and Parts

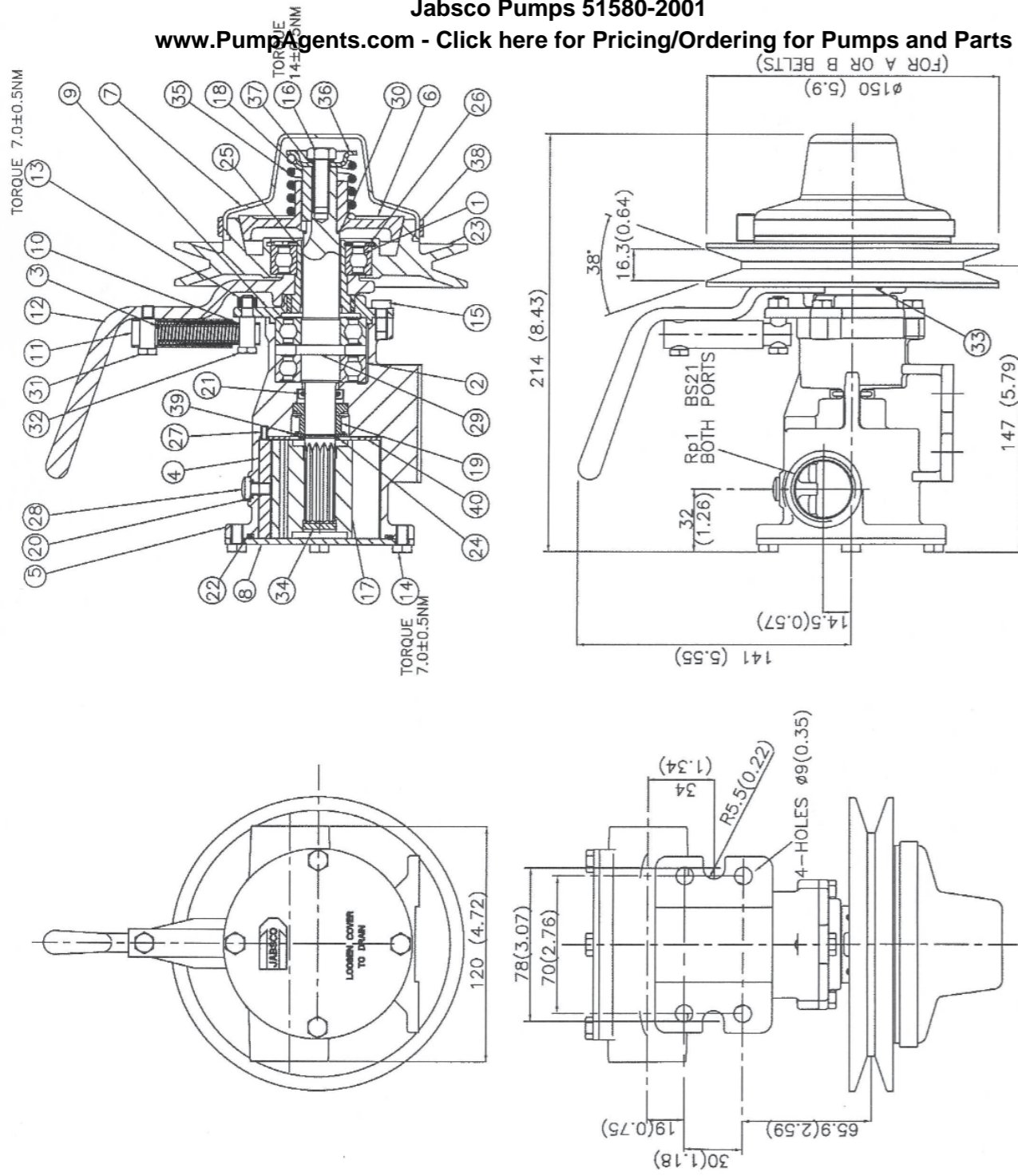

Models 51580-Series

MANUAL CLUTCH DRIVEN FLEXIBLE IMPELLER PUMP

FEATURES

- Carbon /Ceramic mechanical seal
- Sealed for life spaced bearings
- 1" NPT or 1" BSP ports
- Multi position mounting foot
- Standard pressure Jabco neoprene impeller
- Manual clutch

MODEL RANGE

Pump Model	Port Size
51580-2001	1" BSP
51580-9001	1" NPT

APPLICATION

Marine; engine cooling, bilge pumping, washdown and deck flooding, ballast transfer, general purpose pump, fire fighting.

Industrial; circulation and transfer of water, sump drainage, cellar drainage, emergency pumping.

Farming/Agriculture; waste water removal, shallow well pump, ditch drainage.

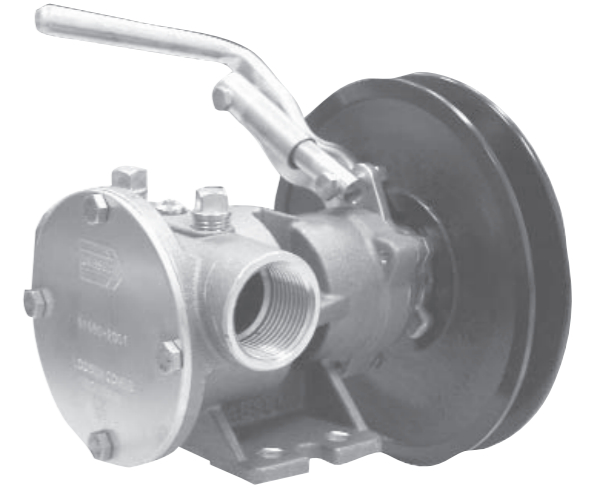

Models 51580-Series

Do NOT run dry.

INSTALLATION

Pumps must be securely mounted on a rigid surface. Pumps can be mounted in any position. If mounted vertically, ensure the bearings are above the pump head to ensure long life.

The rotation of the pump shaft determines the location of the inlet and outlet port. All pipework must be supported to avoid stress on the pump. Suitable fittings must be used to connect the piping to the pump and sealed accordingly. Inlet pipework must be either rigid or reinforced to avoid collapsing under vacuum.

Excessive belt tension will result in premature bearing failure. The belt should be set to allow 16mm (1/2") of movement over 1m (3ft) of span when pushed

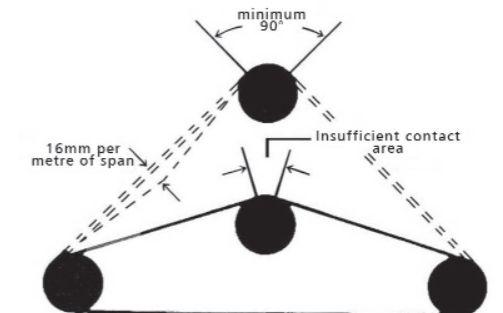

Jabco, 1 Kondelin Road, Cape Ann Industrial Park, Gloucester, MA 01930
 Tel: +1 978 281 0440 Fax: +1 978 283 2619

USA

Jabco, Bingley Road, Hoddesdon, Hertfordshire, EN11 0BU
 Tel: +44 (0) 1992 450 145 Fax: +44 (0) 1992 467 132

UK

NHK Jabco Co Ltd, 3-21-10, Shin - Yokohama Kohoku-ku, Yokohama 222
 Tel: +81 (0) 45 475 8906 Fax: +81 (0) 45 475 8908

JAPAN

Jabco GmbH, Oststraße 28, 72844 Norderstedt
 Tel: +49 (0) 40 53 53 73 0 Fax: +49 (0) 49 53 53 73 11

GERMANY

Jabco Italia, s.r.l., Via Iommaseo, 6, 20059 Vimercate, Milano
 Tel: +39 039 685 2323 Fax: +39 039 666 307

ITALY

Warranty: All products of the company are sold and all services of the company are offered subject to the company's warranty and terms and conditions of sale, copies of which will be furnished upon request. The information provided herein is for guidance only, it does not constitute a guarantee of the performance or specification of any individual product or component.

© 2012 Xylem, Inc. All rights reserved. JABSCO is a registered trademark of Xylem Inc. or one of its subsidiaries.

WARNING: Do not use any Jabco pump for petrol, petroleum products or any products with a flash point below 37°C (98°F), explosion or death may occur.

Injury hazard. Exposed pulleys and belts can cause injury. Install shield around pulleys and belts. Stay clear while machinery is operating.

Ideal belt contact area should not be less than 90° of the pulley circumference. Ensure that all moving parts are adequately guarded to prevent accidents.

OPERATION

Pumps are dry self priming. If fluid does not enter pump after 30 seconds, stop pump, and check inlet hose for leaks and/or blockages.

Maximum speed for these pumps is 2200 rpm, do not operate pump outside the published limits without consulting the factory appointed distributor.

Do NOT allow liquid to freeze in the pump, drain pump by loosening end cover screws.

SERVICE INSTRUCTIONS

Inspect all parts for wear or damage and replace as necessary.

DIS-ASSEMBLY CLUTCH

1. Remove snap on cover.
2. Unscrew spring retaining bolt at end of shaft, remove retainer, spring and clutch cone.
3. Remove one retaining bolt from guide tube assembly.
4. Unscrew bolts holding engaging mechanism housing to body. Remove complete clutch assembly including pulley and engaging mechanism from pump.
5. Remove key and shim from shaft.
6. To break down handle, pulley and engaging mechanism, remove small retaining ring at bearing, support pulley, and press engaging mechanism sleeve through bearing in handle and remove handle from engaging mechanism.
7. Remove retaining ring from pulley and push out bearing.

DIS-ASSEMBLY PUMP

1. Remove end cover screws, end cover, and o-ring.
2. Remove spline seal and impeller using impeller removal tool.
3. Remove cam screw, cam, and wearplate.
4. Remove seal retaining ring.
5. Remove bearing dust seal (if fitted) and bearing retaining ring (if fitted)

6. Carefully push shaft from pump end to remove shaft bearings assembly.
7. Remove seal from body.
8. Remove slinger o-ring and press off bearings.

RE-ASSEMBLY PUMP

1. Press bearing onto shaft and fit into body.
2. Replace bearing retaining ring (if fitted) and dust seal (if fitted).
3. Fit o-ring slinger.
4. Carefully install seal in pump body ensuring seal faces are clean and fit seal retaining ring.
5. Fit wearplate, cam, and cam screw ensuring cam screw o-ring seal is in place.
6. Fit impeller using a small amount of suitable grease.
7. Fit spline seal, o-ring, end cover, and end cover screws.

RE-ASSEMBLY CLUTCH

1. Screw engaging mech/sleeve into housing 1 turn. Fit handle over sleeve and set 0.25mm (1/10") clearance between housing and handle when in the disengaged position by screwing sleeve out as required. Lock handle on sleeve using grub screws.
2. Re-fit bearing and retaining ring into pulley. While supporting clutch mech/sleeve press pulley bearing assembly onto sleeve hard up against handle.
3. Fit entire assembly to pump with 3 bolts.
4. Fit guide tube mechanism to handle and to engaging mechanism housing.
5. Fit shim and key into shaft.
6. Fit clutch cone, spring and spring retainer and secure with bolt. Tighten bolt until retainer is clamped against shaft. NB lubricate between shaft and clutch cone with anti-scuffing paste. Assemble screw with loctite.
7. Re fit snap on cover.
8. Clutch adjustment is possible to extend pump life. Dis-assemble as above and re-assemble without fitting shim onto shaft.

PERFORMANCE (UK & US Versions)

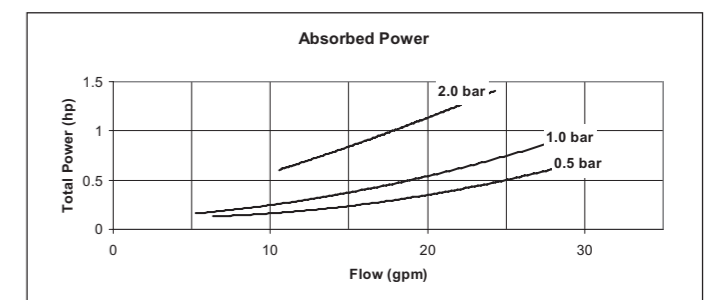
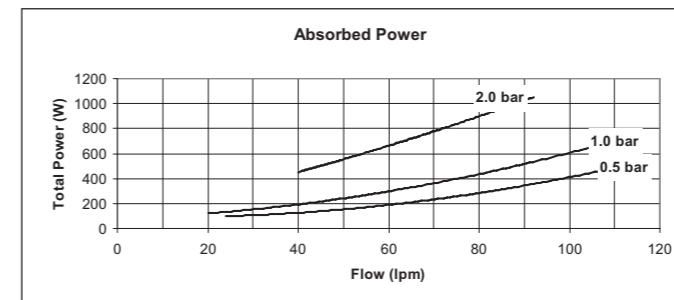
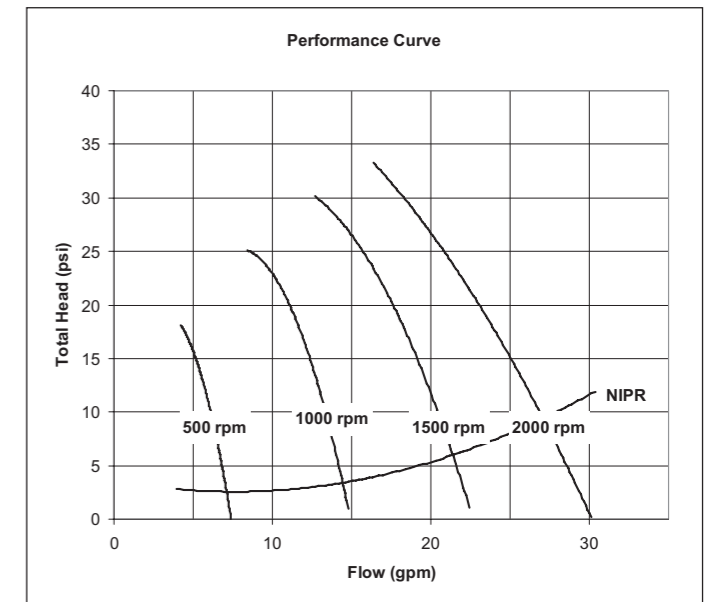
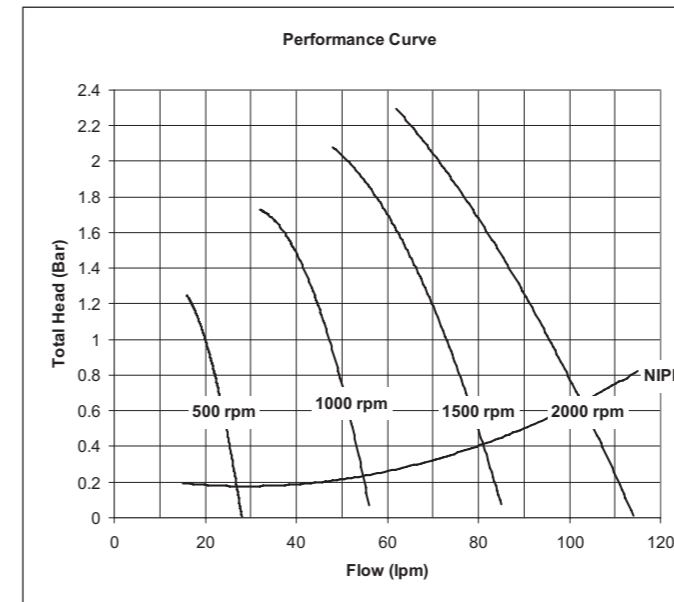

PARTS LIST

Key	Description	Part Number	Qty
1	Bearing	SP2600-11	1
2	Bearing	SP2601-0468	2
3	Brake Spring	51093-0000	1
4	Cam	53082-0000	1
5	Casting Body 080	51584-2100	1
6	Clutch Cone	51085-0000	1
7	Cover	51092-0000	1
8	End Cover	50355-0000	1
9	Engaging Mechanism	51090-0000	1
10	Guide Tube Inner	51088-0000	1
11	Guide Tube Outer	51089-0000	1
12	Handle-Clutch 080	51083-0000	1
13	Hex Head Nut	X3070-091F	1
14	Hex Head Screw	X3001-176F	4
15	Hex Head Screw	X3001-178F	3
16	Hex Head Screw	X3001-211F	1
17	Impeller 080	920-0101	1
18	Key 5x5x28	X4000-209A	1
19	Mech Seal	96080-0620	1
20	O-Ring	X4020-106A	1

Key	Description	Part Number	Qty
21	O-Ring	X4020-215A	1
22	O-Ring	X4020-269A	1
23	Pulley 080	51084-0000	1
24	Retaining Ring	SP1700-62	1
25	Retaining Ring	SP1700-98	1
26	Retaining Ring	SP1700-206	1
27	Roll Pin	SP3100-10	1
28	Screw	X3003-176F	1
29	Shaft 080	51587-0000	1
30	Shim 080	51091-0000	1
31	Shoulder Bolt	51094-0000	1
32	Shoulder Bolt	51095-0000	1
33	Socket Set Screw	X3009-145F	2
34	Spline Seal	4345	1
35	Spring	X5250-001	1
36	Spring Retainer	51086-0000	1
37	Spring Washer	X3081-101C	1
38	Strap	SP8048-1238	1
39	Support Washer	29706-0000	1
40	Wearplate	4156	1