

JABSCO®

Self-Priming Pumps

MODEL 903 - SERIES

MODEL 903 - SERIES

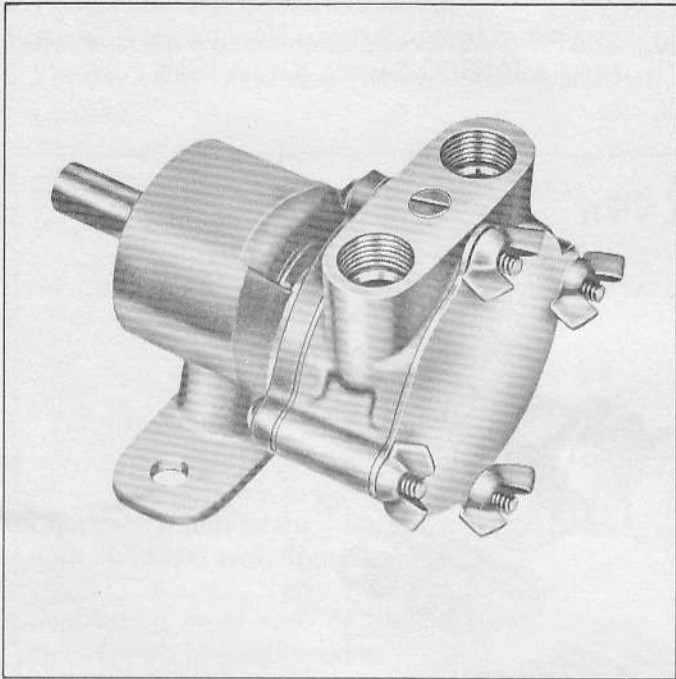

MODEL 903-0001

DESIGN FEATURES

Body:	Type 316 Stainless Steel
Impeller:	Neoprene, Nitrile, Viton*
Seal:	Mechanical Rotary Type with Replaceable Seal Seat.
Wearplate:	Replaceable
Shaft:	Type 316 Stainless Steel
Bearings:	Sealed Pre-lubricated Ball Bearing
Pedestal:	Type 316 Stainless Steel
Ports:	3/8" NPT Internal
Weight:	3 lbs (1,4 kg) approx.

VARIATIONS AVAILABLE

MODEL	DESCRIPTION
903-0001	Neoprene Impeller
903-0003	Nitrile Impeller (Oil Resistant) Mechanical Seal
903-0021	Neoprene Impeller - Lip Seal
903-0024	Viton Impeller - Lip Seal and O-Ring

APPLICATION

INDUSTRIAL: Circulating and transferring corrosive liquids. Returning spilled liquids to process. Transferring foaming solutions with entrained air, such as soaps and detergents. Industrial and processing systems. Ideal for sampling and pilot plant installations. Circulating non-abrasive slurries (low speed). Transferring inks, dyes, sizes, starches, etc. Circulating through various-type filters.

PHARMACEUTICAL: Processing medicines, lotions, preparations. Filtering pharmaceutical solutions.

CHEMICAL: Circulating and transferring various chemicals such as alcohols, ammonia, barium, copper sulphate, cyanide solutions, nickel chloride, silver nitrate, sodium bicarbonate, sodium thiosulphate. Circulating and transferring various acids such as boric, carbonic, citric, phosphoric, tartaric, etc. Circulating photo processing solutions including fix and developer. Recirculating through electroplating filters. Circulating and transferring alkaline solutions.

OPERATING INSTRUCTIONS

1. **INSTALLATION** — Pump may be mounted in any position. The rotation of the pump shaft determines the location of the pump's intake and discharge ports. Refer to dimensional drawing. Before starting, turn the pump shaft in the direction of the operating rotation.
2. **DRIVE** — Belt or Direct with flexible coupling. **DIRECT DRIVE** — Clearance should be left between drive shaft and pump shaft when installing coupling. Always mount pump and align drive shaft before tightening the coupling set screw.

*Viton is a trademark of E. I. Du Pont de Nemours and Company.

ITT JABSCO

3. SPEEDS—100 RPM to the maximum shown in the performance table. For longer pump life, operate at lowest possible speeds.
4. SELF-PRIMING—Primes at low or high speeds. For vertical dry suction lift of 6 feet, a minimum of 800 RPM is required. Pump will produce suction lifts up to 20 feet when wetted. BE SURE SUCTION LINES ARE AIRTIGHT OR PUMP WILL NOT SELF-PRIME.
5. DISCHARGE LINE—When transferring liquids further than 25 feet, use 1/2" or larger discharge line.
6. RUNNING DRY—Unit depends on liquid pumped for lubrication. DO NOT RUN DRY FOR MORE THAN 30 SECONDS. Lack of liquid will severely damage the impeller.
7. NOTICE—If pumping light fraction petroleum derivatives, solvents, thinners, highly concentrated or organic acids, consult Jabsco Chemical Resistance Table (which is available upon request from ITT Jabsco) for proper body materials and impeller compounds. If corrosive fluids are handled, pump life will be prolonged if pump is flushed with water after each use or after each work day.
8. PRESSURES—For continuous operation, pressure should not exceed 15 PSI.
9. TEMPERATURE — Neoprene 45° — 180° F (7°—82° C), Nitrile 50°—180° F (10°—82° C), Viton 60°—180° F (15°—82° C).
10. SPARE PARTS—To avoid costly shut downs, keep a JABSCO Service Kit on hand.

EXPLODED VIEW

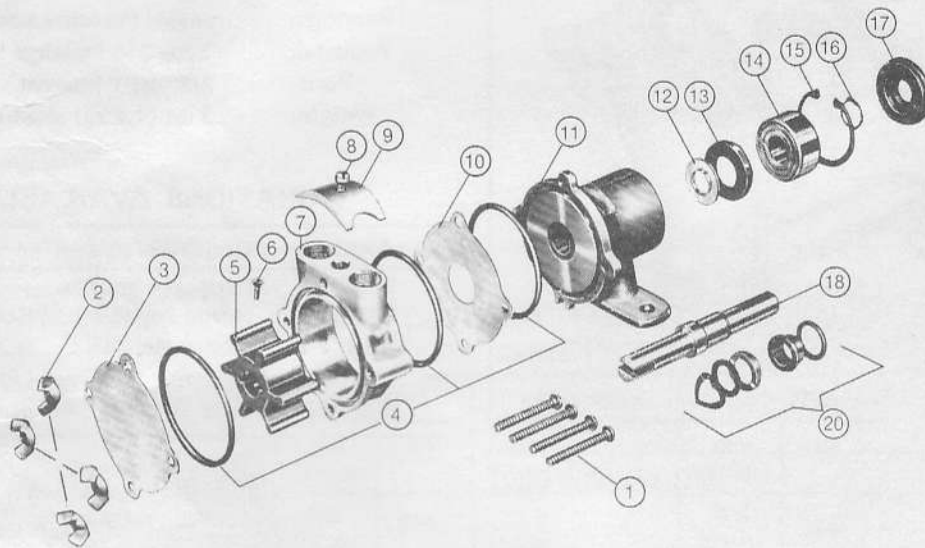

PARTS LIST

KEY	DESCRIPTION	PART NO.	QTY. REQ.	KEY	DESCRIPTION	PART NO.	QTY. REQ.
1	Bolt (End Cover)	91093-0010	4	13	Bearing Seal (Inboard)	918-0000	1
2	Wing Nuts (End Cover)	91107-0010	4	14	Ball Bearing	92600-0070	1
3	End Cover	12061-0000	1	15	Retaining Ring (Brg. Hsg.)	18714-0000	1
4	*O-Ring Standard Viton	92000-0410 92000-0770	3	16	Retaining Ring (Brg. to Shaft)	18715-0000	1
5	*Impeller Neoprene Nitrile Viton	1133-0001 1133-0003 3398-0004	1	17	Bearing Seal	915-0000	1
6	Screw (Impeller)	91029-0070	1	18	Shaft	868-0000	1
7	Body	864-0000	1	19	Key (Not Shown)	11847-0010	1
8	Screw (Cam)	91041-0010	1	20	*Seal Assembly Mechanical Lip (Std.) Lip (Viton)	1177-0000 6456-0000 6456-0010	1
9	Cam	900-0000	1	Not Shown	Service Kit-Mech. Seal, Neo.	90012-0001	
10	Wearplate	891-0000	1		Service Kit-Lip Seal, Neo.	90012-0021	
11	Bearing Housing	869-0000	1		Service Kit-Viton Lip Seal	90012-0034	
12	Slinger	879-0000	1		Service Kit-Nitrile, Mech. Seal	90012-0003	

*Parts supplied in Service Kit.

SERVICE INSTRUCTIONS

DISASSEMBLY

CAUTION: PUMPS WHICH HAVE HANDLED CORROSIVE, CAUSTIC OR TOXIC FLUIDS SHOULD BE DRAINED AND COMPLETELY FLUSHED PRIOR TO SERVICING. FAILURE TO DO SO MAY CAUSE INJURY.

1. Remove wing nuts and end cover.
2. Remove through bolts, body and wearplate.
3. Remove O-rings from body and pedestal.
4. Remove impeller from body or shaft.
5. Loosen cam screw and remove cam. Clean off sealant.
6. Remove Marcel washers from shaft.
7. Using hooked wire, remove seal assembly, seal seat and seal seat O-ring.
8. Using extreme care not to mar the pedestal bore, insert screwdriver between O D of outboard bearing seal and pedestal bore and pry out the seal.
9. Remove pedestal retaining ring.
10. Pressing on impeller drive end of shaft, remove shaft and bearing assembly from pedestal. NOTE: Slinger will drop from drain area.
11. Using extreme care not to mar the pedestal bore, insert screwdriver between O D of inboard bearing seal and pedestal bore and pry out the seal.
12. Remove shaft retaining ring.
13. Supporting bearing inner race and pressing on pump drive end of shaft, remove bearing from shaft.

NOTE: Inspect all parts for wear or damage and replace as necessary.

ASSEMBLY

1. Lubricate I D of bearing seal and install in pedestal with lip facing away from bearing.
2. Supporting inner race of bearing, press keyway end of shaft through bearing.
3. Install shaft retaining ring.
4. Place slinger in drain area on top of seal boss and insert slotted end of shaft through bearing bore and slinger until bearing contacts the pedestal.
5. Pressing on outer race of bearing, press shaft and bearing assembly into pedestal.
6. Install pedestal retaining ring with flat side toward the bearing.
7. Lubricate I D of outboard bearing seal and install in pedestal with lip facing away from bearing.
8. Seal Assembly
Mechanical Seal:
 - a. Install seal seat and seal seat O-ring. (Moisten O-ring with water and install with rotary motion, and assemble in pedestal seal bore insuring it is all the way into the seal cavity.)
 - b. Install ferrule and ferrule O-ring assembly with O-ring against the seal seat.
 - c. Install Marcel washers over shaft and down against rubber washer cemented to ferrule assembly.Lip Seal:
 - a. Install O-ring in seal bore against the shoulder.
 - b. Lubricate lip of seal with petroleum jelly and install in seal bore with lip facing outward.
 - c. Install retaining ring.
9. Apply thin coat of sealant to screw threads and top of cam. Install cam in body with cam screw.
10. Install bolts through pedestal from pump drive end.
11. Install O-ring in pedestal O-ring groove.
12. Install wearplate aligning holes with bolts.
13. Install impeller drive screw in impeller and align screw with slot in shaft, slide impeller over shaft and down against the wearplate.
14. Lubricate impeller bore of body with petroleum jelly, install O-rings in O-ring grooves and aligning holes with bolts, install over impeller and down against the wearplate.
15. Install end cover and secure with wing nuts.

**DIMENSIONAL DRAWING
INCHES (MILLIMETRES)**

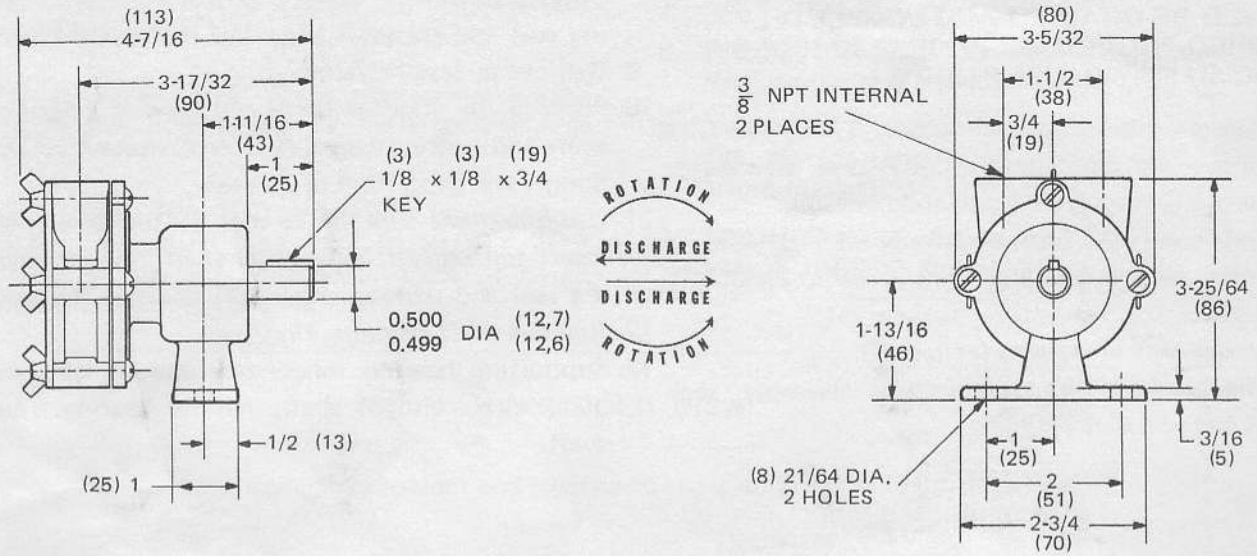

**HEAD CAPACITY TABLE
NEOPRENE IMPELLER**

TOTAL HEAD		500 RPM		1160 RPM		1750 RPM	
PSI (kg/sq.cm)	ft. of water (metre)	GPM (L/min)	HP	GPM (L/min)	HP	GPM (L/min)	HP
4.3 (0,3)	10 (3,0)	1.3 (4,9)	1/20	3.9 (14,8)	1/6	5.8 (22,0)	1/4
8.7 (0,6)	20 (6,1)	0.6 (2,3)	1/20	2.9 (11,0)	1/6	5.0 (18,9)	1/4
13.0 (0,9)	30 (9,1)			1.6 (6,1)	1/4	3.6 (13,6)	1/4

Head capacity values for Nitrile and Viton impellers are approximately 10% less. Do not exceed 15 PSI for continuous operation.

NOTE: Progressively longer life may be expected as operating pressures and speeds are reduced. Capacitor type motor recommended. Table shows approximate head-flow for new pump in U.S. gallons per minute.

THE PRODUCTS DESCRIBED HEREIN ARE SUBJECT TO
THE JABSCO ONE YEAR LIMITED WARRANTY, WHICH
IS AVAILABLE FOR YOUR INSPECTION UPON REQUEST.

ITT JABSCO

A Unit of ITT Corporation
1485 Dale Way, P.O. Box 2158
Costa Mesa, CA 92628-2158
Telephone: (714) 545-8251