

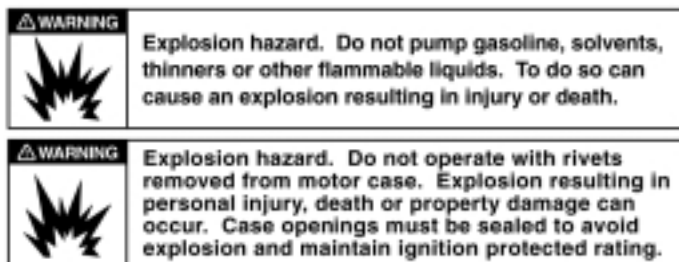

Model 45740-0000

115 Vac ROTARY VANE PUMP FEATURES

Body:	Bronze
Rotor:	Vectra*
Vanes:	Ryton**
Seal:	Lip type, Nitrile
Motor:	1/8 HP, 115 Vac-60 Hz T.E.N.V. 3450 RPM with Thermal Overload Protection and 6' Cord
Ports:	1 Inch External Hose Barb 1/2 Inch Internal Pipe Threads
Height:	5-3/4"
Length:	9-3/4"
Width:	5-5/8"
Weight:	14-1/2 lbs.



APPLICATION

The Jabsco rotary vane pump is ideal for pumping light oil or transferring diesel fuel. The rotor and vanes are not affected by petroleum products. It is self-priming with a suction lift of up to five feet and can pump against a discharge head of up to twenty feet. The motor is rated for continuous duty in applications with a total system head no greater than twenty feet and when pumping liquids with a similar viscosity to diesel fuel. When pumping light oils, the duty cycle should be no longer than thirty minutes.

INSTALLATION

The 115 Vac vane pump can be used as a portable pump or mounted permanently in pumping system. It can be mounted on any flat surface. However, it is advisable to mount it so the motor shaft remains horizontal. The pump head may be rotated on the motor 180° to accommodate plumbing connections as needed or to change the direction of flow.

PLUMBING CONNECTIONS

Pump ports have external 1" hose barb and internal 1/2" pipe threads. Use hose that does not kink when bent and with sufficient wall thickness to prevent collapse when

* Vectra is a registered trademark of Celanese Corporation

** Ruton is a registered trademark of Phillips Chemical Company



Model: 45740-0000

used on suction side of pump. Hoses should be routed so that some fluid will be retained in pump body to wet the rotor and vanes.

Wetting the rotor and vanes aids in priming. Use a strainer on the intake hose if trash or solids are present in the fluid being pumped. Diesel fuel and used oil may contain debris or contaminants which require the use of a fine mesh screen strainer. ALL HOSES MUST HAVE AIRTIGHT CONNECTIONS TO ENABLE FAST PRIMING.

PERFORMANCE DATA

PSI	TOTAL HEAD		CAPACITY	
	FEET	METRES	GPM	I/MIN
2.1	5	1,5	8.5	32
4.3	10	3,0	8.2	31
8.7	20	6,1	1.4	5,3
13.0	30	9,1	7.8	30

Table shows approximate Head-Flow for new pump pumping diesel fuel. If pumping water, flow rates are reduced approximately 20%.

NOTICE: Do not exceed above performance parameters or pump damage may occur.

OPERATION

Rotary Vane pumps must NOT be run dry, as the pumped liquid is the lubricant for the rotor and vanes. Observe the outlet and shut off pump as soon as liquid stops flowing.

The pump cannot run against a closed outlet as encountered when using a garden hose type shut-off nozzle. Pressure for normal operation should not exceed 20 feet of head (8.7 psi). Excessive pressures will cause motor to overheat tripping the thermal overload protector.

Temperature of pumped liquid may range from 45°–165° F (7°–74° C). When pumping engine oil, run engine long enough to heat oil to about 150°F (66° C).

**DIMENSIONAL
DRAWING**

Inches (Millimetres)

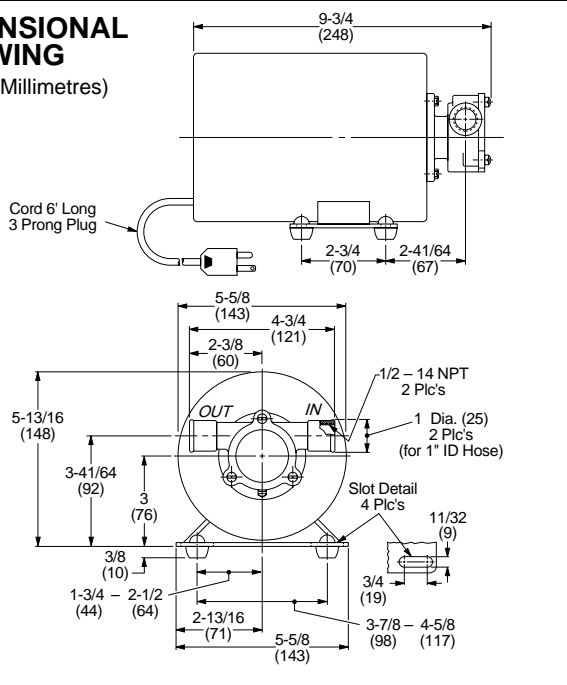
**WARNING**

Explosion hazard. Do not pump volatile liquids with a flash point below 100°F (38°C). Doing so can cause an explosion or fire resulting in injury or death.

NOTE: Diesel fuel has a flash point of 100°-190° F (43°-88° C).

DISASSEMBLY

1. Remove end cover screws, end cover and O-ring.
2. Withdraw rotor and vanes.
3. Loosen and remove two slotted hex screws, which attach body to motor.
4. Tap body lightly between ports and remove body from motor.
5. Press seal from the rotor side of the body out of the seal bore.

ASSEMBLY

1. Press seal from the motor side of the body into the seal bore with lip pointing toward the rotor bore.
2. Lubricate motor shaft and install body on motor.
3. Aligning flat in rotor with flat on motor shaft, install rotor. Install vanes in vane slots of rotor.
4. Install O-ring, end cover and end cover screws.

MAINTENANCE

Periodic cleaning of rotor and vanes will ensure proper pump performance and extend rotor/vane life.

In most applications, pump vanes should last about 250 hours and the rotor should last about 500 hours. Timely replacement of vanes and rotor will maintain maximum performance. The seal should be expected to last about 500 hours in most applications.

Frequent cleaning of intake strainer (when used) will minimize intake suction and prolong pump life.

If pump is to be in freezing temperatures, drain by loosening end cover screws.

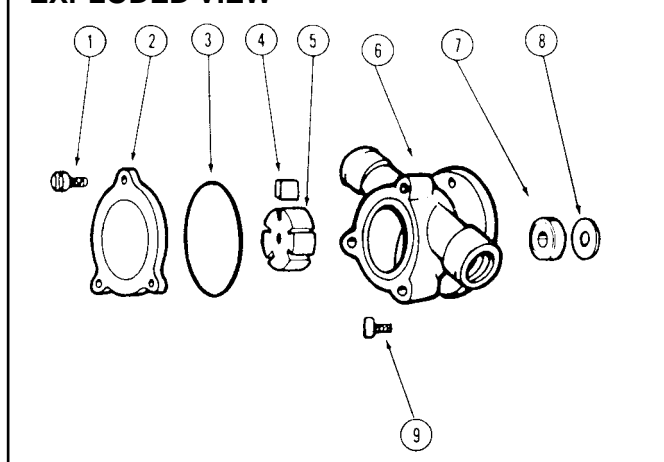
EXPLODED VIEW**PARTS LIST**

KEY	DESCRIPTION	PART NUMBER	QTY.
1	Screw Kit (4/kit)	91004-0090	1
2	End Cover*	18753-0070	1
3	O-Ring*	18753-0071	1
4	Vanes (set of 5)*	18753-0072	1
5	Rotor*	18753-0073	1
6	Body	18753-0135	1
7	Seal*	1040-0000	1
8	Slinger	6342-0000	1
9	Screw Kit (2/kit)	98019-0020	1
	Motor (not shown)	18753-0082	1
	Service Kit	90200-0000	

* Parts contained in Service Kit.

Jabsco



ITT Industries
Engineered for life



PumpAgents.com - buy pumps and parts online

THE PRODUCTS DESCRIBED HEREIN ARE SUBJECT TO THE JABSCO ONE YEAR LIMITED WARRANTY, WHICH IS AVAILABLE FOR YOUR INSPECTION UPON REQUEST.

For technical advice or service please take your pump into your local pump service center.
To order pump or parts or for pricing please go to the following links :

[Jabsco Pumps Home >>](#)

[Jabsco Pumps stock list >>](#)