



# Model 36800-Series 36900-Series

## ELECTRIC WATER SYSTEM PUMPS

### Automatic Multi-Outlet

#### FEATURES

- Self-Priming
- Diaphragm Design Allows Dry Running
- Built-in Discharge Check Valve
- Quiet Operation
- Built-in Hydraulic Pulsation Dampener
- Large Vibration Absorbing Pads
- Ports Available with Barb or Threads
- Meets USCG Electrical Standards

#### SPECIFICATIONS

Open Flow	U.S. GPM	Litres/min	Imp. GPM
36800-Series:	3.3	12,5	2.75
36900-Series:	4.2	15,9	3.5
<b>Cut-in Pressure (Nominal):</b>	20 psi (1.4 bar)		
<b>Cut-off Pressure (Nominal):</b>	40 psi (2.7 bar)		
<b>Vert. Dry Suction Life:</b>	5 Feet (1,52 m)		
<b>Ports:</b>	Slip on 1/2" to 5/8" ID hose		
<b>Approx. Ship. Weight</b>			
36800-Series:	11 lb (5,0 kg)		
36900-Series:	12 lb (5,4 kg)		

#### DIMENSIONAL DRAWING

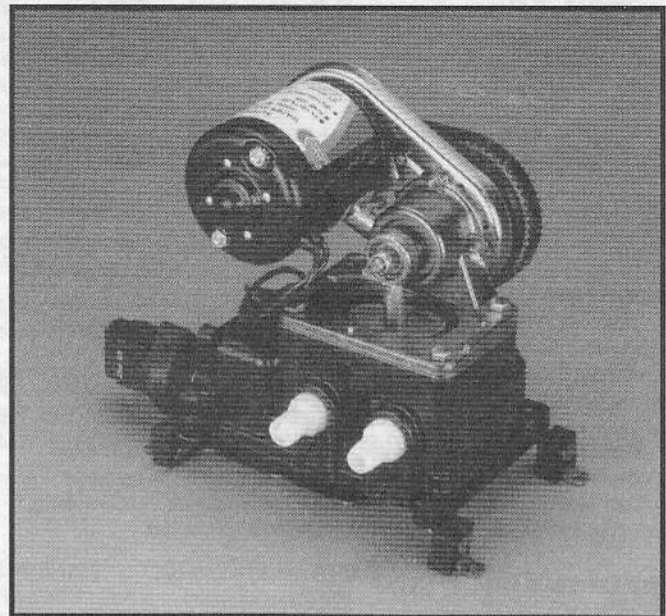
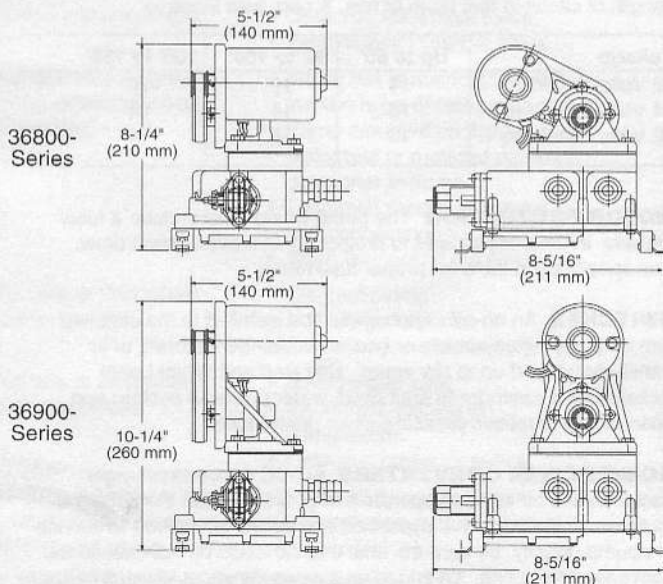

Model 36800-Series, 36900-Series

#### APPLICATIONS

Jabsco automatic water system pumps are designed for self contained recreational vehicles and pleasure boats with multiple outlet water systems. The systems are automatic – when a faucet is opened, the pump instantly begins operation to provide a constant flow from tank to faucet. Closing the faucet automatically discontinues pump operation. Model 36800 is suited for up to five outlet distribution systems. Model 36900 is recommended for large distribution systems where duty requires simultaneous operation for multiple faucets.

#### STANDARD MODELS

##### 36800-Series – Automatic Water System

Model	Voltage	Nom. AMP Draw	Pressure		FUSE/BREAKER*
			Cut-in psi (bar)	Cut-out psi (bar)	
36800-1000	12 Vdc	6.0	20 (1.4)	40 (2.7)	8 amp
36800-0200	12 Vdc	6.0	10 (0.7)	20 (1.4)	8 amp
36800-1010	24 Vdc	3.0	20 (1.4)	40 (2.7)	4 amp
36800-0210	24 Vdc	3.0	10 (0.7)	20 (1.4)	4 amp

##### 36900-Series – Automatic Water System

Model	Voltage	Nom. AMP Draw	Pressure		FUSE/BREAKER*
			Cut-in psi (bar)	Cut-out psi (bar)	
36900-1000	12 Vdc	7.5	20 (1.4)	40 (2.7)	15 amp
36900-0200	12 Vdc	7.5	10 (0.7)	20 (1.4)	15 amp
36900-1010	24 Vdc	3.8	20 (1.4)	40 (2.7)	5 amp
36900-0210	24 Vdc	3.8	10 (0.7)	20 (1.4)	5 amp

\* Customer supplied, not included with pump.

Jabsco



U.S.A.  
ITT Jabsco  
1485 Dale Way, P.O. Box 2158  
Costa Mesa, CA 92628-2158

UNITED KINGDOM  
ITT Jabsco  
Bingley Road, Hoddesdon  
Hertfordshire EN11 0BU

CANADA  
ITT Fluid Products  
55 Royal Road  
Guelph, Ontario N1H 1T1

THE PRODUCTS DESCRIBED HEREIN ARE SUBJECT TO THE JABSCO ONE YEAR LIMITED WARRANTY, WHICH IS AVAILABLE FOR YOUR INSPECTION UPON REQUEST.

JAPAN  
NHK Jabsco Company Ltd.  
3-21-10, Shin-Yokohama  
Kohoku-Ku, Yokohama, 222

GERMANY  
MINTEC GmbH  
Oststrasse 28  
22844 Norderstedt

## INSTALLATION

### PLUMBING

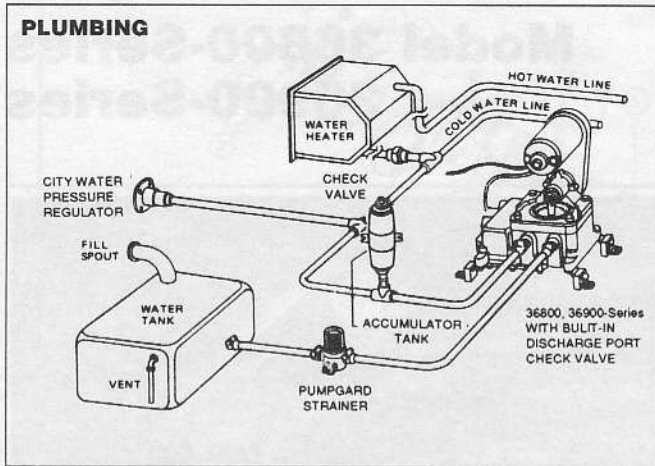

**MOUNTING** Jabsco diaphragm pumps are self-priming. They may be located above or below the fresh water tank. The pump is equipped with vibration pads which are most effective when the pump is mounted upright on a solid surface. Selection of a cool, dry ventilated location will generally extend pump life.

**PLUMBING** To minimize water pressure drop, the size of water supply line should not be less than sizes shown in table below. Valves, elbows, etc. used should be the same size as pipe or tubing. Use gate valves only. Fresh water tank must be vented.

### MINIMUM PIPING SIZE

Supply Line Length	Tubing ID	Pipe Size
Less than 48"	1/2"	3/8"
48" or more	5/8"	1/2"

**PRESSURE REGULATOR** It is recommended that systems having a connection for a city water entry be equipped with a pressure regulating check valve set at approximately 35 psi. This valve automatically regulates the incoming water pressure to avoid damage to pump and plumbing from excessive pressures. Models 44410-Series (Permanent Flush Mount) and 44410-1010 (in-line Hose Type) pressure regulating valves are recommended for this purpose.

**CHECK VALVES** A built-in port check valve protects the pump from the unregulated high pressure sometimes encountered in city water hookups. However, an additional check valve may be installed at the cold water inlet of the water heater to minimize heat transfer to the cold water line and protect the system in case of water heater relief valve failure. Jabsco offers qualified in-line check valves, Models 34344-0000, 35027-0000 and 35195-0000.

**SUCTION STRAINER** A Pumpgard No. 36400-0000 (strainer/filter) is recommended, installed between the pump and fresh water tank. It helps prevent valve clogging caused by foreign material entering the pump.

**WATER PURIFIER** Many water purifiers cause excessive restriction to flow, especially when element is in use for some time. When used at the main distribution line, it causes the pump to cycle on and off rapidly. To minimize cycling, use an accumulator tank between pump and purifier, or install purifier to feed a single outlet for drinking-water only.

**ACCUMULATOR TANK** The use of an accumulator tank (Jabsco Model 30573-0000, 12573-2000 or 18810-0000), although not required, is recommended for a more effective water distribution system. It eliminates "water hammer," stores pressures to allow a limited use of water without restarting pump (desirable at night-time), assures a constant, even stream of water at faucets farthest from pump and prolongs pump life by cutting down rapid start/stop operation.

### WIRING

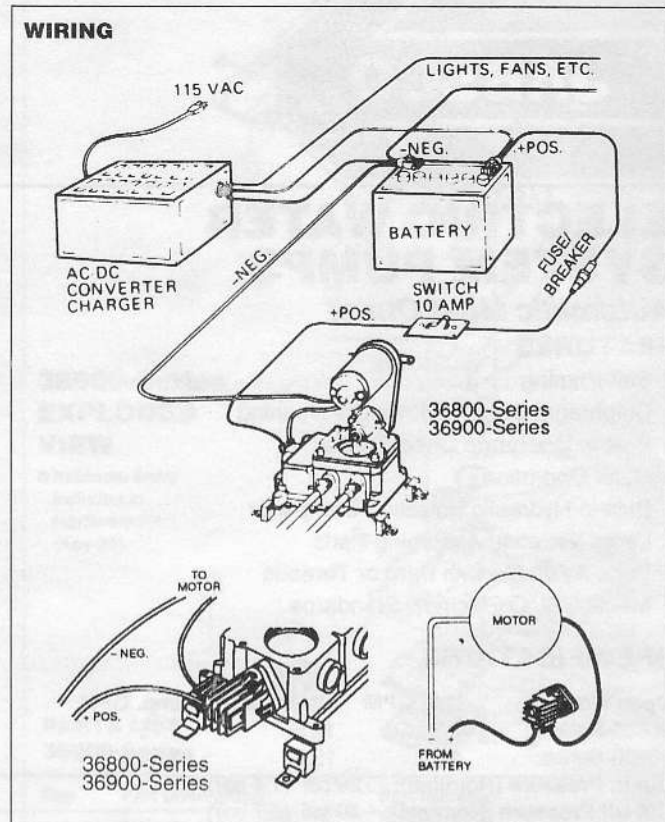

**WIRING** Pump should be wired in a circuit independent of all other accessories according to the wiring diagram.

### WIRE SIZE CHART (A.W.G. - COPPER)

Length of circuit in feet (sum of pos. & neg. wire lengths)

Voltage	Up to 80'	80' to 100'	100' to 150'
12 Volts Two Wire	14	12	10
24 Volts Two Wire	16	14	14
32 Volts Two Wire	16	16	14

**MOTOR PROTECTION** The pump wiring must include a fuse/breaker in the positive lead to protect against overcurrent draw. See specification table for proper fuse rating.

**SWITCHES** An on-off switch should be installed in the circuit to turn off pump when vehicle or boat is unattended, stored, or in transit, or hooked up to city water. Use Red and White Label included as a reminder to shut down water pressure system and open faucet to relieve pressure when unattended.

**AC-DC POWER CONVERTERS** AC-DC converter/charger packs should be wired to operate pump directly from the battery at all times. If the battery is bypassed and converter is used to service the pump directly, be sure the total electric loads do not exceed the converter amp rating. Overloading the converter could result in low-voltage condition at the pump.

**VOLTAGE CHECK** After installation, check the voltage at the pump motor. Voltage should be checked when pump is operating along with all the inside electrical fixtures. Full voltage must be available at the pump motor at all times.

## OPERATION

- Check level of water in tank. Be sure valves are open and strainers and aerators are clean.
- Open all faucets, hot and cold.
- Turn on power to pump.
- Close each faucet when it starts to deliver a steady stream of water (close cold water first).
- Observe the pump. Check to be sure pump stops soon after all faucets are closed.
- Pump is now ready for automatic operation. It will start when a faucet is opened and stop when the faucet is closed.
- Turn off power to pump and open faucet to relieve system pressure prior to city water or dockside hook-up and when unattended.

## MAINTENANCE

**WINTER STORAGE** Jabsco pumps, with its unique pulsation dampener, will withstand frozen water without damage provided the system is not under pressure prior to freezing. To prevent accidental damage, the entire water system should be protected from freezing during winter storage. This requires complete draining, using the following directions and/or vehicle manufacturer's instructions:

1. Open all faucets and drains and allow pump to empty water tanks and intake line. Run the pump dry for 1 to 2 minutes before turning off.
2. With all drains open, blow air through city water entry. Allow time for water heater to empty.
3. Disconnect discharge and intake hoses from the pump. Start the pump and allow to run until all water is expelled from unit. (Running dry will not harm the pump).
4. Reconnect the hoses, close the drains and leave faucets open. The water distribution system is now dry and ready for winter storage.

An alternate method is to use potable water system anti-freeze solution. Follow directions of anti-freeze manufacturer.

**⚠ DANGER** DO NOT USE AUTOMOTIVE TYPE ANTI-FREEZE. IT IS POISONOUS. USE OF THIS TYPE ANTI-FREEZE WILL CAUSE SERIOUS INTERNAL INJURY OR DEATH.

## SERVICE

### TROUBLESHOOTING

#### Problem

Pump operates but no water flows through faucet.

#### Causes

- Low water level in tank.
- Water lines are clogged.
- Kink in water hose.
- Air leak suction.
- Dirty or hard-to-open in-line check valve.
- Defective pump valve.

Pump cycles on and off when faucets are closed.

- Water leak in plumbing.
- Defective toilet flush valve.
- Internal leak in output valve.

Pump operates roughly and has excessive noise and vibration.

- Intake line is restricted, kink in suction hose or fittings too small.
- Pump mounted on flimsy board.
- Deformed or ruptured pulsation dampener in pump.
- Loosened screws at pulleys and connecting rod.
- Worn connecting rod bearing.

Pump fails to start when faucet is opened.

- Clogged piping.
- No voltage to pump.
- Defective pressure switch.

Pump fails to stop when faucets are closed.

- Empty water tank.
- Insufficient voltage to pump motor.
- Defective pressure switch.

**NOTICE:** Before servicing pump, turn off power and open faucets to relieve pressure in water distribution system. Failure to do so could cause water to spray in cabin.

### VALVES ASSEMBLY REPLACEMENT

1. Remove motor and four jack shaft assembly tie down screws. Lift jack shaft assembly to expose valves.
2. Lift valves from pockets. Clean all foreign materials from valves and seats. Inspect rubber flappers for cuts.
3. Reinstall valves into same pockets, being sure rubber valve with small hole is UP on intake and rubber valve without the small hole is DOWN on discharge.  
NOTE: Do not use valve with small hole in rubber on discharge side of pump or pump will operate incorrectly.
4. Replace motor, do not overtighten belt.

### DIAPHRAGM & CONNECTING ROD REPLACEMENT

1. Remove motor and four jack shaft assembly tie down screws, then lift jack shaft and attached diaphragm assembly from pump base.
2. Expose diaphragm by removing two diaphragm retainer screws and detaching retainer.
3. Remove diaphragm screw to separate diaphragm, plates and washer/spacer from connecting rod. Inspect diaphragm for cuts and ruptures.
4. Remove locking nut to separate connecting rod from jack shaft.
5. When reassembling, be sure to align diaphragm and connecting rod so that rod slips straight onto jack shaft and diaphragm rests squarely on diaphragm retainer.
6. Replace motor, do not overtighten belt.

### PULSATION DAMPENERS REPLACEMENT

1. Remove nine screws from bottom plate and three screws from small bottom plate. Mark bottom of small plate for proper reassembly.
2. Pull out rubber pulsation dampeners from base. Inspect for excessive deformation, ruptures and cuts.
3. When installing new large pulsation dampener, check that its metal screw sleeve-guide is positioned between center hole and screw-way in the base. Make sure that flanges of both pulsation dampeners are well-seated to effect a proper water and air seal.

### SWITCH REPLACEMENT - PROCEDURE A

Direct replacement of switch with threaded stem directly into pump body.

1. Disconnect power leads from switch and remove switch from pump.
2. Moisten rubber side of washer with water. Thread washer onto switch threads with metallic side of washer facing switch. Apply a thin film of sealing compound to the replacement switch threads. Keep compound clear of passage-way hole.
3. Screw replacement switch into pump base/body until snug.
4. Reconnect switch power leads.

### 36800-Series EXPLODED VIEW

● Indicates items included in Hardware Kit (Key 21).

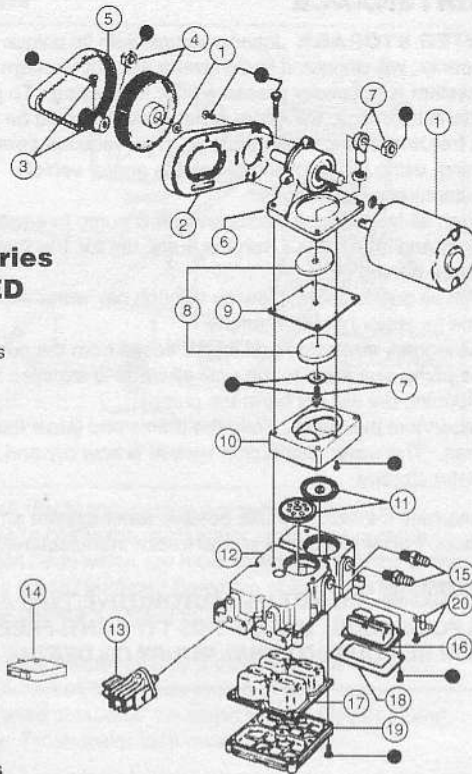

### PARTS LIST 36800-Series

Key	Part Description	Part Number	Qty
1	Motor Kit 12 Vdc.	30200-0000	1
1	Motor Kit 24 Vdc	30200-0010	
1	Motor Kit 32 Vdc	30200-0020	
2	Motor Mount	34628-0000	1
3	Small Pulley	37169-0000	1
4	Large Pulley	37170-0001	1
5	Belt	30021-0000*	1
6	Jack Shaft Assembly	35506-0001 - See Note 5	1
7	Connecting Rod Assembly	37173-0001 - See Note 5	1
8	Diaphragm Plate	35503-0000	2
9	Diaphragm	30015-0000*	1
10	Retainer	35497-0000	1
11	Valve Set (Inlet & Outlet)	30004-0000†	1 Set
12	Base Assembly†	35625-1100 †	1
13	Pressure Switch	37121-0010 - See Note 3 37121-0000 - See Note 2 44814-1000 - See Note 1	1
14	Micro Switch only	18753-0141	1
15	Ports (Inlet & Outlet) Barb	37176-0000† - See Note 4	1 Set
16	Small Pulsation Dampener	37177-0000†	1
17	Pulsation Dampener	37178-0000†	1
18	Small Bottom Plate	35628-0000†	1
19	Bottom Plate	35623-0000†	1
20	Vibration Pad Kit	37180-0000†	1 Set
21	Hardware Kit	37165-0001	1 Set
	Service Kit *	30122-0000	

### 36900-Series EXPLODED VIEW

● Indicates items included in Hardware Kit (Key 21).

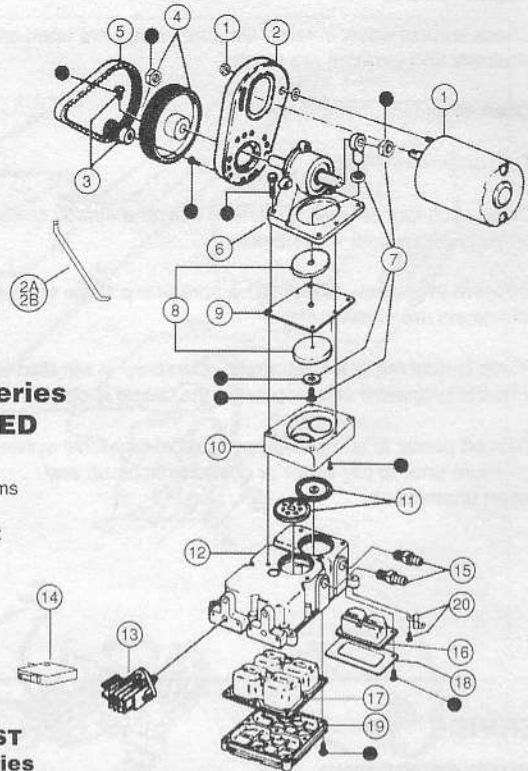

### PARTS LIST 36900-Series

Key	Part Description	Part Number	Qty
1	Motor Kit 12 Vdc	30200-0000	1
1	Motor Kit 24 Vdc	30200-0010	
1	Motor Kit 32 Vdc	30200-0020	
2	Motor Mount	34628-0000	1
2A	Brace (Left)	35256-0010	1
2B	Brace (right)	35256-0020	1
3	Small Pulley	37169-0000	1
4	Large Pulley	37170-0001	1
5	Belt	30021-0000*	1
6	Jack Shaft Assembly	35690-0001 - See Note 5	1
7	Connecting Rod Assembly	37173-0001 - See Note 5	1
8	Diaphragm Plate	35212-0000	2
9	Diaphragm	30016-0000*	1
10	Retainer	35173-0000	1
11	Valve Set (Inlet & Outlet)	30004-0000†	1 Set
12	Base Assembly†	35625-1100 †	1
13	Pressure Switch	37121-0010 - See Note 3 37121-0000 - See Note 2 44814-1000 - See Note 1	1
14	Micro Switch only	18753-0141	1
15	Ports (Inlet & Outlet) Barb	37176-0000† - See Note 4	1 Set
16	Small Pulsation Dampener	37177-0000†	1
17	Pulsation Dampener	37178-0000†	1
18	Small Bottom Plate	35628-0000†	1
19	Bottom Plate	35623-0000†	1
20	Vibration Pad Kit	37180-0000†	1 Set
21	Hardware Kit	37165-0001	1 Set
	Service Kit *	30121-0000	

\* Indicates Parts Contained in Service Kit. † Indicates Parts Supplied with Base Assembly.

### MOTOR REPLACEMENT

1. Remove two motor nuts to separate motor.
2. Loosen set screw to remove small pulley from motor shaft.
3. When reassembling, adjust belt tension so belt between pulleys can be depressed 1/4" after motor nuts are tightened. Do not overtighten belt.

### NOTE 1

Low Pressure Switch 10(0.7) to 20(1.4) psi

### NOTE 2

Includes Switch and Conversion Kit to Mount New Style Switch Onto Older Style-J and -0000 Pumps.

### NOTE 3

Replacement Switch only for -1000 Series Pumps. Meets USCG Electrical Standards.

### NOTE 4

1/2" Threaded Outlet Port 37050-0001  
1/2" Threaded Inlet Port 37050-0000

### NOTE 5

Jack shaft assembly kit, with part number ending in -0001 includes new style connecting rod (37173-0001) with a 5/16" diameter hole and two (2) locknuts. Previous model pumps use a connecting rod (37173-000) with a 1/4" diameter hole and a bolt.