



## Model 34739-Series

### FLANGEMOUNT 3" BLOWER

#### FEATURES

- Tough Reinforced Plastic Housing
- Mount to Any Flat Surface
- Slip-On Inlet Ducting Connection
- Efficient High Volume Air Flow
- Low-Current Draw
- Corrosion-Resistant Materials Throughout
- N.M.M.A. Type Accepted
- DC Models Comply with USCG Electrical Regulations of Title 33, Chapter I, Part 183; Subpart I and ISO 8846 MARINE for Ignition Protection
- DC Models Comply with ISO 9097 Marine
- DC Models Conform with EN 50081-1 for Suppression of Electromagnetic Interference

#### SPECIFICATIONS

Model	Air Flow	Voltage	Amps	Fuse Size	Weight lb(kg)
34739-0010	150 CFM (4.0 m <sup>3</sup> /min.)	12 Vdc	6.5	10A	5 (2.3)
34739-0020	150 CFM (4.2 m <sup>3</sup> /min.)	24 Vdc	3.3	5A	5 (2.3)
34739-0031	150 CFM (4.0m <sup>3</sup> /min.)	115 Vdc	0.8	1.25A 125V	5 (2.3)

**WIRING FOR DC MODELS:** Use stranded copper wire. For lengths up to 25 feet (7.6m) from power source: Use 12 gauge wire for 12 Volt and 14 gauge wire for 24 Volt. Use larger wire for longer lengths. Use a 10 amp rated on-off switch in positive side of circuit (Model 44960-0003). Circuit must be protected with a fuse. Suggested fuse sizes are listed in the specifications table.

**WIRING FOR AC MODEL:** Use 16 gauge stranded copper wire for lengths up to 100 feet from power source. Connect the grounded, unswitched conductor (white) to the white motor lead. Connect the undergrounded, switched conductor (black) to the black motor lead. This conductor should include, at the power source, a 1.25 amp 125 Volt fuse. The green motor lead must be connected to the AC circuit ground.

#### INSTALLATION

**INSTALLATIONS MUST MEET APPLICABLE SECTIONS OF TITLE 33, PART 183; SUBPART K, USCG VENTILATION REGULATIONS.**

**MOUNTING:** Mount blower on flat bulkhead surface in highest part of compartment free from spray or deck wash. Cut 2-3/4" hole in bulkhead and secure blower with washers and No. 10 screws.



Model 34739-Series

**(NOTICE:** Tighten screws evenly to avoid flange damage). Use outlet collar No. 34856-0000 to connect ducting to discharge vent. Use a suitable discharge fitting so that static pressure of blower will not be affected by change in wind direction. Route inlet ducting with as few bends as possible to lower 1/3 of bilge compartment where vapors are likely to accumulate. Be sure ducting is positioned below top of engine stringers but not so low as to become submerged in bilge water. Locate pickup to take advantage of natural air flow direction. Flexible ducting No. 34959-0100 is easy to cut and install.

**NOTICE:** Blower should be mounted away from extreme heat (more than 130°F) to prevent distortion of blower wheel or housing.

For an exposed inlet, ventilator intake screen No. 34764-0000 provides a safe and attractive protected inlet. **NOTE:** This blower may also be mounted with inlet through bulkhead, using intake collar No. 34943-0000.

Jabsco blowers are primarily intended for intermittent duty cycles such as evacuating fuel vapors from bilge areas. If desired, they also may be used for other general air circulation applications with longer duty cycles. However, when doing so, it should be noted that the maximum motor life is approximately 1000 hours. Therefore, the blower should only be used for applications if this length of service is acceptable.

**OPERATION:** See following warning placard statement:



The "WARNING" placard supplied with blower must be mounted adjacent to engine ignition switches (all Locations) to comply with Title 33, Part 1834; Subpart K, USCG Ventilation Regulations.\*

\*Additional warning placards are available from factory by requesting form 43003-0418.

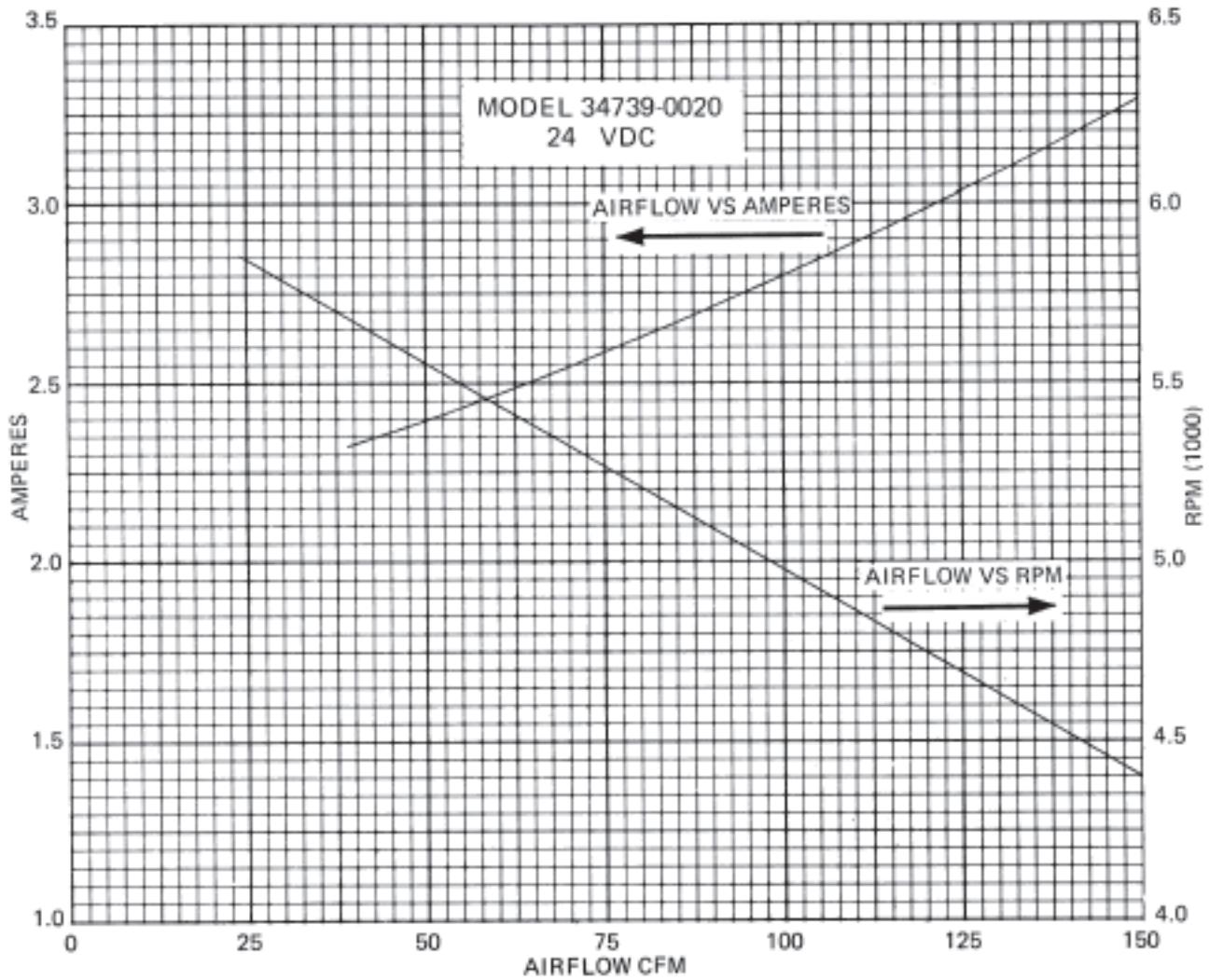
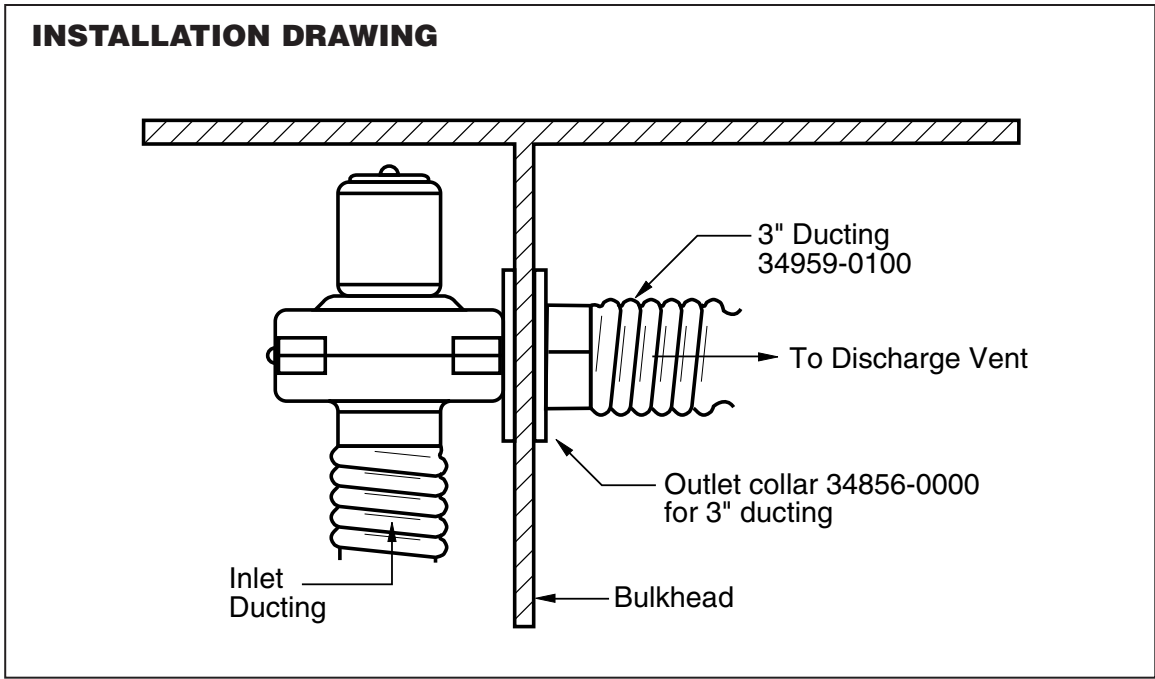

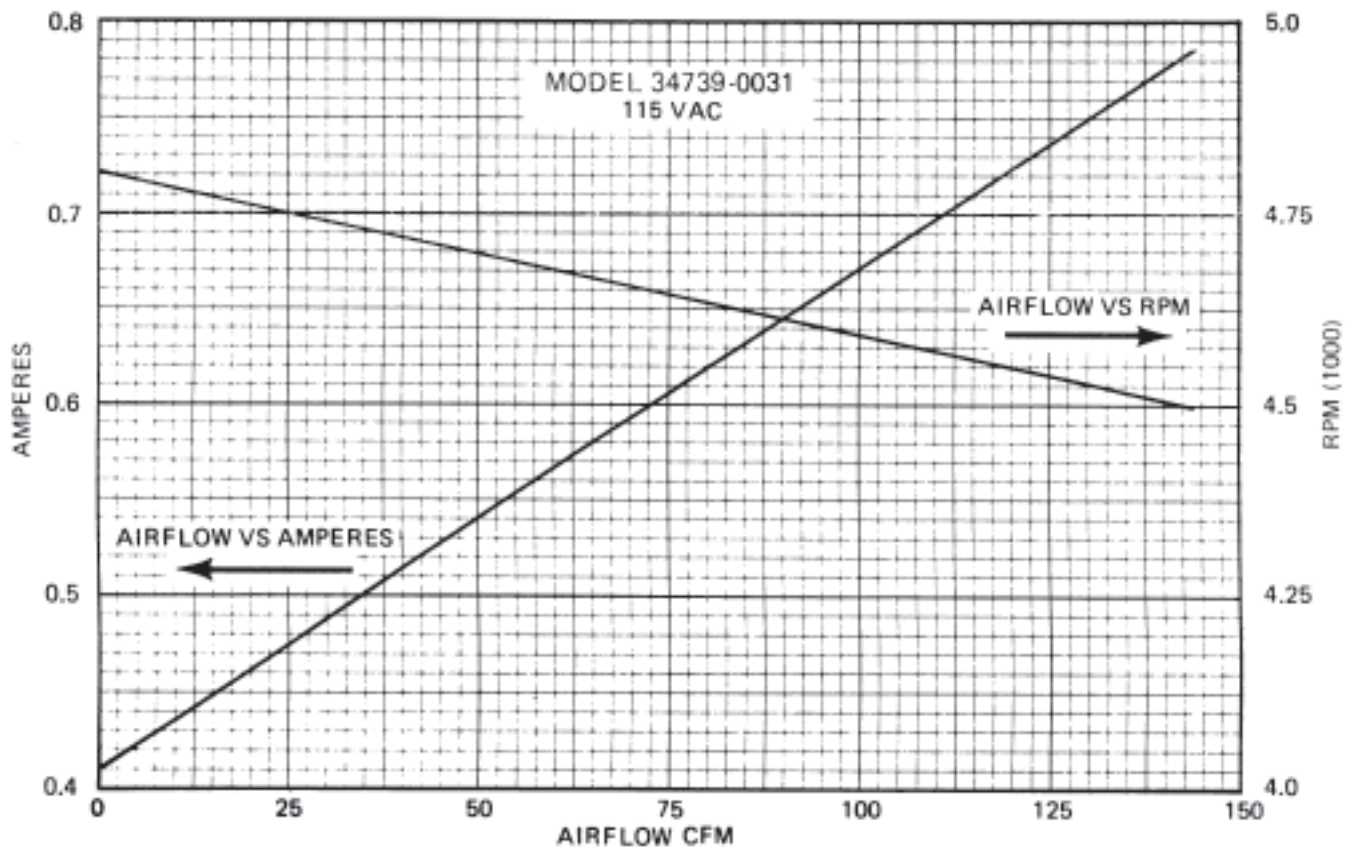
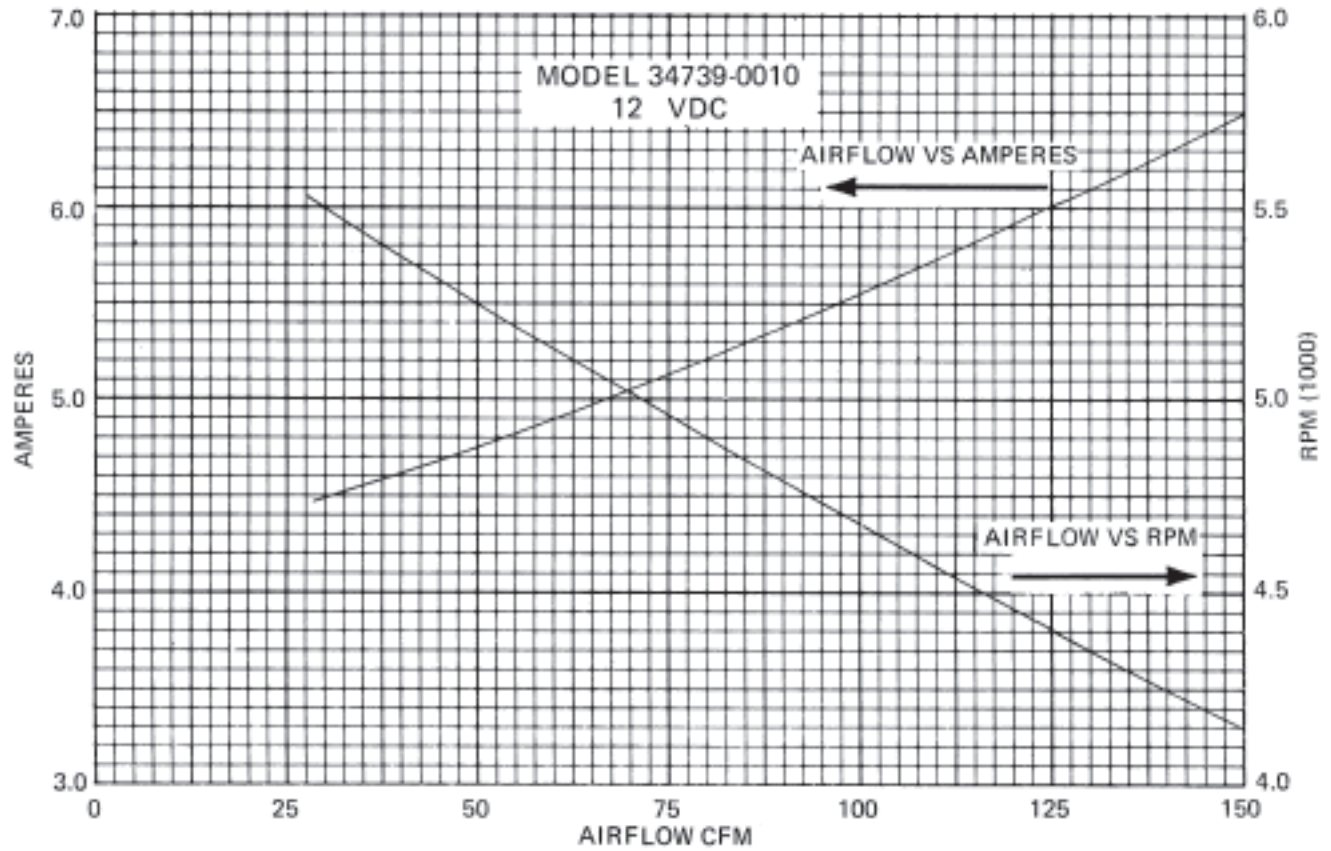

**PARTS LIST**

Key	Description	Qty.	Part Number
1	Motor Kit	1	
	12 VDC		30200-0000
	24 VDC		30200-0010
	32 VDC		30200-0020
	115 VDC		30200-0050
2	Blower Housing	1	35744-0000
3	Blower Wheel	1	34742-0000
4	Blower Housing	1	35775-0000
5	Screw 8 x 5/8 SS Self Tapping Pan Head	5	35508-0000

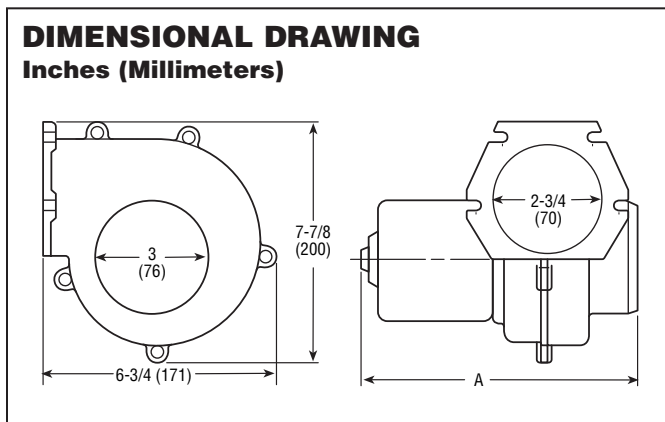
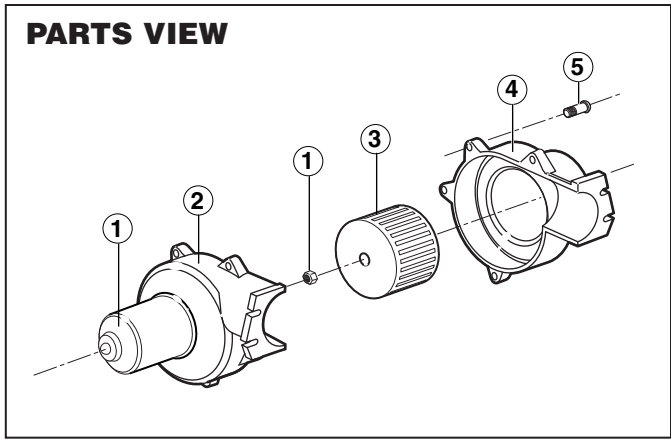

Model	Dimension A
34739-0010	7-7/8" (200)
34739-0020	7-7/8" (200)
34739-0031	8-3/8" (213)

**MARINE SWITCH PANELS**

These rocker switch panels are available in an attractive black textured finish. Select between two models with or without illumination. All lighted models are complete with silicon seal boot.

44960-0002 and 44960-0003 include durable stick-on labels for all popular screws.

Model	# Position	Elec. Rating
44960-0002	2 (on, off lighted)	10 amps/12 Vdc
44960-0003	2 (on, off unlighted)	10 amps.6-32 Vdc 10 amps/110 Vdc

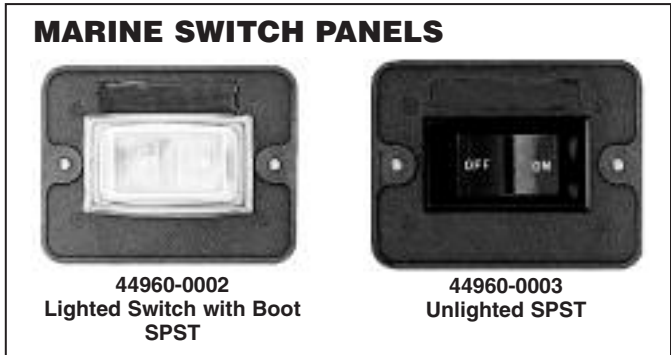

For more information  
visit us online at [www.jabsco.com](http://www.jabsco.com)