



Models 31750-Series 3.7 GPM
31755-Series 4.5 GPM

SENSOR-MAX VSD WATER SYSTEM

FEATURES

- Variable Speed Control
- Solid State Pressure Sensor
- Nearly Silent Operation / No Cycling
- Operates on 12V DC or 24V DC
- Controls Pressure by Changing Motor Speed
- Speeds Up As Demand Increases
- Self-priming / Runs Dry
- No Accumulator Tank Needed
- CSA Listed / EN ISO 8846 Marine / C.E. Certified
- Protected under U.S. Patent #6,607,360
- Includes Inlet Strainer

SPECIFICATIONS

- Motor: Permanent magnet, double ball bearing armature. Electronic speed control built into rear endball.
- Pump: Four chamber positive displacement diaphragm design. Self-priming up to 10 feet suction lift. Pump able to run dry without damage. Removable port adapters.



Models 31750 & 31755

Model Number	Dimensions - Inches (mm)			Weight lb. (kg)
	Height	Width	Length	
31750-0000	3.75 (95)	6.3 (160)	9.0 (221)	4.3 (2)
31755-0000	3.75 (95)	6.3 (160)	10.3 (252)	6.3 (3)

Model Number	Voltage	Amp Draw (24V)	Max Fuse	Flow GPM (LPM)	Sensor Pressure	Cut-Out Pressure	Inlet Strainer
31750-0000	12-24V DC	8.0 (4.0)	15A	3.7 (13.5)	25 psi (1.7 bar)	35 psi (2.8 bar)	Yes
31755-0000	12-24V DC	12.0 (6.0)	15A	4.5 (16.3)	30 psi (2.1 bar)	40 psi (2.8 bar)	Yes

OPERATION

Mount the pump in a dry, ventilated location. The inlet strainer must be installed between the fresh water supply and the pump inlet port. The supply tank should be at least half full prior to initial operation.

NOTE: The VSD electronics require a battery installed in the DC power supply when using an AC to DC converter or battery charging system.

IMPORTANT: Polarity of electrical connections is very important. Insure that the RED (+) motor lead is

connected to a fused positive DC circuit. The BLACK (-) motor lead must be connected to the negative DC circuit. In the event that polarity is reversed, in-line fuse must be replaced.

To prime the plumbing system, open all the faucets and turn on the power to the pump. Shut off each faucet as it begins to run free of air. As the last faucet is closed the pump will slow down and shut off.

QUICK EASY INSTALLATION

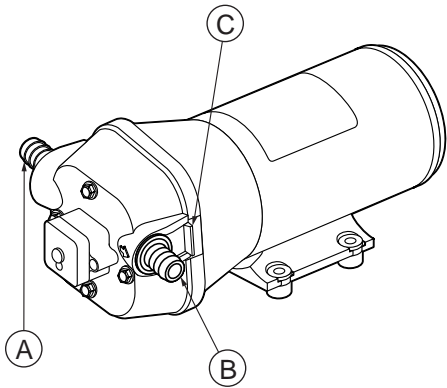

INSTALLATION LAYOUT

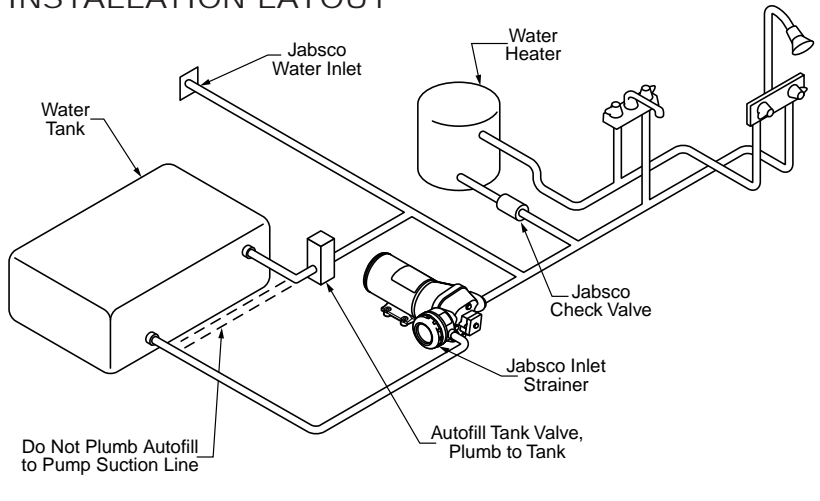

INSTALLATION

STEP 1

Remove the shipping plugs from the pump ports. Some water from factory testing may spill out.

STEP 2

Install strainer on inlet A and port adapter on outlet B. Firmly push slide clips C forward to lock strainer and port adapter in place. Install port adapter to strainer inlet (not shown) and firmly push slide clip forward to lock port adapter.

STEP 3

Push the 4 rubber grommets into base plate mounting holes.

STEP 4

Mount pump horizontally, or vertically with the pump head lower than the motor. Any plumbing leak should not drip on the motor.

STEP 5

3/4" ID hose may be used (preferably braided or reinforced) to isolate pump from plumbing system. 1/2" ID hose may be used on 3.7 GPM model. Use hose clamps on hose barb connector and strainer if applicable.

STEP 6 (OPTION)

Install the 40 mesh in-line strainer in an accessible location between the supply and the pump inlet A.

WIRING DIAGRAM

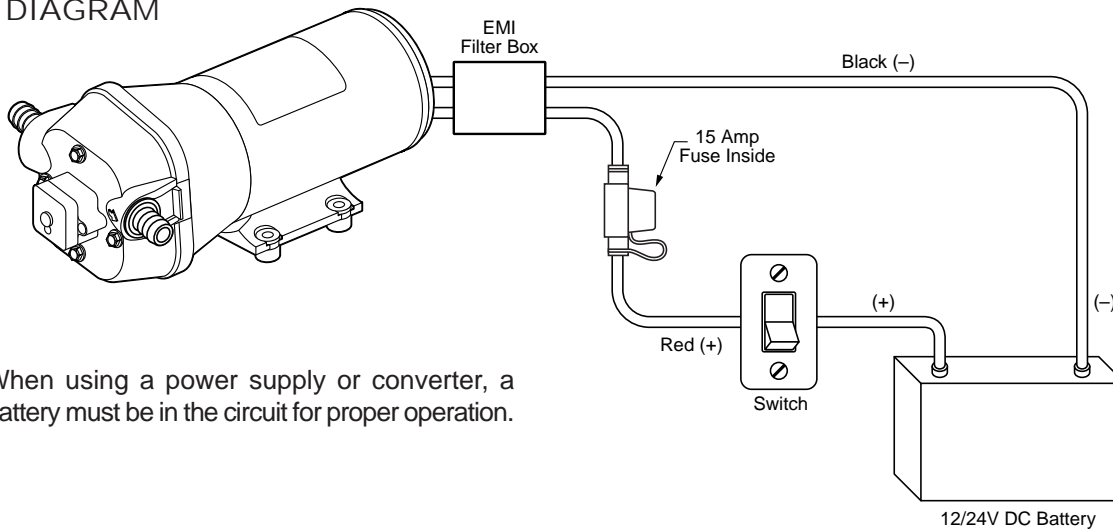

NOTE: When using a power supply or converter, a battery must be in the circuit for proper operation.

WIRING

The Automatic Variable Speed Motor Driven Pumps will operate in either a 12 or 24V DC battery system. The unique electronics adjust the voltage and current to the motor as needed.

STEP 1

Use 14 AWG stranded wire to 15 feet, 12 AWG to 30 feet from distribution panel or power source.

STEP 2

Install a 15 amp rated on-off switch on the positive (+) lead from the power source.

STEP 3

Use a 15A fuse breaker in the circuit at the distribution panel.

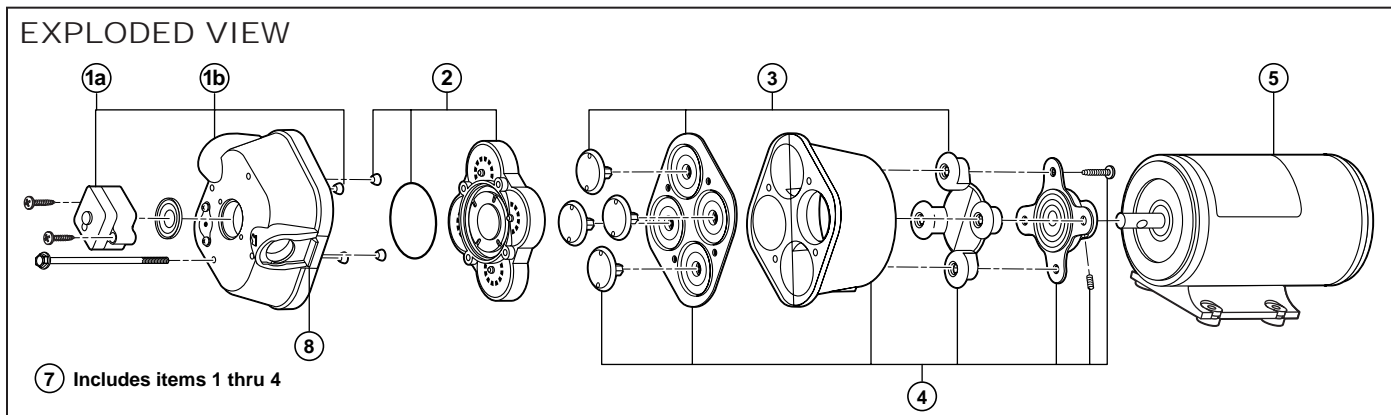

PARTS LIST

Key	Description	Model #31750 Part Number	Model #31755 Part Number
0	Service Kit*	18920-9053	18920-9053
1	Upper Housing with Sensor Housing	18910-4027	18910-4028
2	Check Valve Assembly	18911-7030	18911-7030
3	Diaphragm Assembly (includes screws)	18912-3040	18912-3040
4	Lower Housing Assembly	18915-9002	18915-9002
5	Motors with Sensor	18919-0128	18919-0127
7	Pump Head Assembly	18914-6037	18914-6038
8	Side Clips (pair)	30648-1000	30648-1000

* Service Kit includes #2, #3, #8 and drive cam assembly.

DISASSEMBLE

Pressure Sensor

1. Remove cover (1a) and lift up clip to unplug the sensor (not shown). Remove sensor housing.

Upper Housing

2. Loosen but do not remove the four pump head screws and carefully remove the upper housing assembly (1b).
3. Inspect the B/F valve in center behind sensor for debris.
4. Change the four ferrules sealing the screws.

Check Valve Assembly

5. Inspect the valve flappers for debris and resilience.
6. Replace if necessary.

Lower Housing, Diaphragm, Motor

7. Remove mounting feet to expose notches. Rotate the lower housing (4) so notch opening exposes set screw that holds bearing housing to motor shaft.
8. Loosen the set screw with an 1/8" Allen wrench inserted through the notch opening. Finally, slide lower housing (4) off motor shaft.
9. Remove four piston screws from cam bearing assembly using a Phillips screw driver and pull apart cam bearing assembly from inner pistons.

Motor Cont'd

10. Test motor by carefully connecting red wire to positive (+) and black wire to negative ground (-) of a 12 or 24V DC battery. Motor will run full speed and slow as sensor is brought closer to magnet's south pole. Replace if necessary.

REASSEMBLE

Motor

1. Assemble lower housing assembly (4) to motor. (Follow steps 4 to 10)

Diaphragm

2. Diaphragm (3) and lower housing (4) are assembled in this way:

- Four black inner piston facing stem up on a flat surface, diaphragm flat side up with piston stems through diaphragm.
- White outer piston must be folded to insert into lower housing, flat side up.
- Hex stem of inner pistons must align with hex holes in outer pistons.
- Outer pistons must be aligned with alignment slots on the cam bearing assembly.
- Drive each Phillips head screw partially tight, carefully center each piston in its quadrant, and then tighten the screws securely (18 in. lbs. torque).

Lower Housing

3. Attach lower housing to motor shaft by aligning indentation in shaft with set screw. Set screw must align with the shaft indentation or major damage, poor performance, or high amp draw may result.

Upper Housing, Check Valves

4. View the inside of the upper housing (1) and seat the four ferrules in the pump head screw recesses.
5. Carefully seat the O-ring in the check valve assembly (O-ring must not slip out of the check valve recess).
6. Install check valve assembly into upper housing, pressing firmly. Start the four pump head screws, turning by hand through the ferrule seals, then push through about 1 1/2".
7. Assembly on to lower housing (4), align four screws to motor by rotating lower housing if necessary to align feet.
8. Tighten pump head screws evenly to a water-tight 30 in. lbs. torque.

Pressure Sensor

9. Place sensor housing (1a) and sealing disk against upper housing (1b), insert screws and take care not to cross thread or strip out threads in upper housing.
10. Slide the sensor under the clip on the sensor housing and install the cover.

TROUBLESHOOTING



BEFORE SERVICING PUMP, TURN OFF POWER TO PUMP AND DRAIN SYSTEM!

Problem

Solution

Failure to prime-motor operates, but no pump discharge

- Debris in pump
- Defective check valve assembly
- Air leak in intake line
- Restricted intake or discharge line
- Punctured diaphragm (pump leaks)
- Crack in pump housing (pump leaks)
- Empty water supply tank

- Remove upper housing and clean
- Replace check valve assembly
- Tighten all clamps, inspect plumbing
- Remove lines and inspect
- Replace lower housing assembly
- Replace housing or pump head
- Refill or turn power off to pump

Motor fails to run

- Pump circuit has no power
- Loose or corroded wiring connection
- Blown fuse or open breaker
- Open thermal protector (motor shell hot)
- Defective motor, drive control or pressure sensor

- Check wiring, fuse or breaker
- Inspect wire connections
- Replace or reset
- Wait 20 to 30 minutes for auto reset
- Contact factory, 1-978-281-0440

Pump fails to turn off after all fixtures are closes

- Empty water supply tank
- Air trapped in pump
- Debris in pump
- Defective check valve assembly
- No battery in circuit
- Punctured diaphragm (pump leaks)
- Discharge line leak

- Refill
- Open faucet closest to pump
- Remove upper housing and inspect
- Replace check valve assembly
- Install battery
- Replace lower housing assembly
- Inspect plumbing and fixtures for leaks

Low flow or pressure

- Debris in inlet strainer
- Water filter needs charging
- Undersize plumbing or long runs
- Defective motor, drive control or pressure sensor

- Remove cover and clean screen
- Replace filter cartridge
- Increase plumbing ID
- Contact factory, 1-978-281-0440

ACCESSORIES

Quick Connect Port System

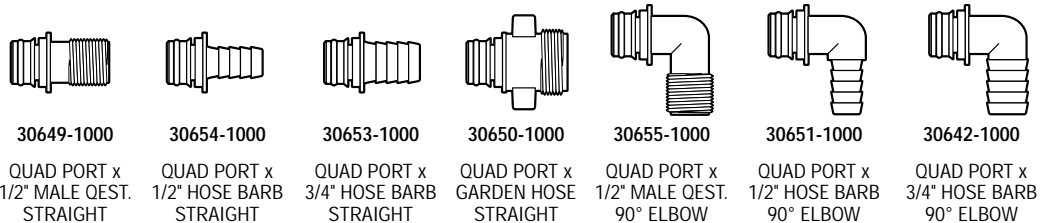

STRAINERS

Pump Series	Strainer Number	Inlet	Outlet	Screen
31750-0000	46400-0012	1/2 Barb	Snap-in Port	40 Mesh
	46400-0021	1/2 Barb	1/2 Barb	40 Mesh
	46400-0004	1/2 M Quest	1/2 M Quest	40 Mesh
	46400-0014*	1/2 M Quest	Snap-in Port	40 Mesh
	46400-9500*	Female Snap-in Port	Snap-in Port	40 Mesh
31755-0000	46400-0000	3/4 Barb	3/4 Barb	40 Mesh
	46400-0004	1/2 M Quest	1/2 M Quest	40 Mesh
	46400-0014*	1/2 M Quest	Snap-in Port	40 Mesh
	46400-9500*	Female Snap-in Port	Snap-in Port	40 Mesh

*Included with pump

Jabsco



PumpAgents.com - buy pumps and parts online

THE PRODUCTS DESCRIBED HEREIN ARE SUBJECT TO THE JABSCO THREE YEAR LIMITED WARRANTY, WHICH IS AVAILABLE UPON REQUEST.

For technical advice or service please take your pump into your local pump service center.
To order pump or parts or for pricing please go to the following links :

[Jabsco Pumps Home >>](#)

[Jabsco Pumps stock list >>](#)