

**JABSCO**

a xylem brand

**SELF-PRIMING PUMPS**

**FEATURES**

- Pump Type:** Pedestal Pump
- Body:** Epoxy Plastic
- Impeller:** Neoprene, Nitrile, Viton\* or EPDM
- Shaft Seal:** Mechanical, Carbon-on-Ceramic, or Tungsten Carbide; Nitrile or Viton
- Ports:** 1" NPT External
- Shaft:** Epoxy Plastic Covered Stainless Steel
- Weight:** 7.0 lb (3.2 kg) Approx.

**VARIATIONS AVAILABLE**

MODEL NO.	DESCRIPTION
<b>30520-1001</b>	Standard Pressure, Neoprene Impeller, Carbon Seal
<b>30520-1003</b>	Standard Pressure, Nitrile Impeller, Carbon Seal
<b>30520-1004</b>	Standard Pressure, Viton Impeller, Carbon Seal
<b>30520-1011</b>	High Pressure, Neoprene Impeller, Carbon Seal
<b>30520-1013</b>	High Pressure, Nitrile Impeller, Carbon Seal
<b>30520-1014</b>	High Pressure, Viton Impeller, Carbon Seal
<b>30520-1101</b>	Standard Pressure, Neoprene Impeller, Tungsten Carbide Seal
<b>30520-1103</b>	Standard Pressure, Nitrile Impeller, Tungsten Carbide Seal
<b>30520-1104</b>	Standard Pressure, Viton Impeller, Tungsten Carbide Seal
<b>30520-1111</b>	High Pressure, Neoprene Impeller, Tungsten Carbide Seal
<b>30520-1113</b>	High Pressure, Nitrile Impeller,



Tungsten Carbide Seal

**30520-1114**

High Pressure, Viton Impeller, Tungsten Carbide Seal

**APPLICATIONS**

<p><b>WARNING</b></p>	<p><b>Explosion hazard. Do not pump gasoline, solvents, thinners or other flammable liquids. To do so can cause an explosion resulting in injury or death.</b></p>
-----------------------	--

**INDUSTRIAL:** Circulating and transferring corrosive liquids. Returning spilled liquids to process, transferring foaming solutions with entrained air, such as soaps and detergents. Sampling and pilot plant installations. Handles pure solutions, acids, alkalies, photo chemicals, dyes, detergents, waxes, gels, solutions with suspended solids and emulsions.

**METAL PLATING:** Filtration of plating solutions. Filling and emptying vats. Adding chemicals for pH balance.

**PHARMACEUTICAL:** Processing lab solutions, medicines, lotions and preparations. Filtering pharmaceutical solutions.

**AGRICULTURAL:** Transferring liquid fertilizers, herbicides and pesticides.

**OPERATING INSTRUCTIONS**

1. **INSTALLATION** – Pump may be mounted in any position. The rotation of the pump shaft determines the location of the pump's intake and discharge ports. (Refer to dimensional drawing.) Pump is normally assembled at factory for clockwise rotation (looking at end cover). If counter clockwise rotation

<p><b>WARNING</b></p>	<p><b>Injury hazard. Exposed pulleys and belts can cause injury. Install shield around pulleys and belts. Stay clear while machinery is operating.</b></p>
-----------------------	--

\* Viton is a trademark of E.I. Du Pont de Nemours and Company.

is desired, follow steps 1 and 2 of disassembly and step 9 of assembly instructions to change direction of impeller blade deflection under cam.

**2. DRIVE** – Belt or direct with flexible coupling.

Belt Drive: Over tight belt load will reduce pump bearing life.

Direct Drive: Clearance should be left between drive shaft and pump shaft when installing coupling. Always mount and align pump and drive shaft before tightening the coupling set screw. If pulley or coupling must be pressed on shaft, remove end cover and impeller to support shaft from impeller end during press operation. Do not hammer pulley or coupling on shaft; this may damage bearing or seal.

**OPERATING INSTRUCTIONS** (Cont.)

Capacitor start motor is required to overcome starting torque of impeller.

**3. SPEEDS** – 100 RPM to the maximum shown in the performance curves. For longer pump life, operate at lowest possible speeds. Lower speeds are required for viscous liquids. Consult the factory for proper speed and horsepower requirements.

**4. SELF-PRIMING** – Primes at low or high speeds. For vertical dry suction lift of 10 feet (neoprene/nitrile/Viton) – 7 feet (EPDM), a minimum of 860 RPM is required. Pump will produce suction lift up to 22 feet when wet. **BE SURE SUCTION LINES ARE AIRTIGHT OR PUMP WILL NOT SELF-PRIME.**

**5. DISCHARGE** – When transferring liquids further than 25 feet, use one size larger discharge line than discharge port size.

**6. RUNNING DRY** – Unit depends on liquid pumped for lubrication. **DO NOT RUN DRY** for more than 30 seconds. Lack of liquid will damage the impeller.

**7. CHEMICAL COMPATIBILITY** – Consult the Chemical Resistance Guide in the JABSCO Industrial Pump Catalog (available upon request from factory) or factory for proper body materials and impeller compounds. If corrosive fluids are handled, pump life will be prolonged if pump is flushed with a neutralizing solution after each use or after each work day. A Tungsten Carbide Seal variation is available for pumping liquids that contain abrasives or are highly corrosive.

**8. PRESSURES** – Consult Performance Curves for maximum recommended pressures for pumps in continuous operation. If pressures exceed those shown, consult the factory.

**9. TEMPERATURES** – The operating temperature limits of the pump depend on the impeller compound. The following ranges apply: Neoprene - 45° to 180° F (7° to 82° C), Nitrile - 50° to 180° F (10° to 82° C), Viton - 60° to 180°F (15° to 82°C), EPDM - 45° to 185°F (7° to 85°C).

**10. IMPELLER TORQUE** – The torque required to initiate rotation of a new impeller in a dry pump body is:

Standard Pressure Impeller (14281-Series):

Forward = 4.8 pounds force-feet

Reverse = 11.2 pounds force-feet

High Pressure Impeller (8890-Series):

Forward = 7.9 pounds force-feet

Reverse = 16.3 pounds force-feet

These values may vary slightly due to impeller compounding, blade set, and body material of construction. Consult factory for more information.

**11. SPARE PARTS** – To avoid costly shutdowns, keep a spare JABSCO impeller, seal and O-ring set on hand.

**SERVICE INSTRUCTIONS**

**DISASSEMBLY**

1. Remove the four end cover screws. Remove end cover and O-ring.
2. Remove the four screws holding the body to the bearing housing flange. Slide body, complete with impeller and wearplate, from pedestal and shaft assembly.
3. Remove mechanical seal by inserting two screwdrivers behind seal collar, and gently lever collar and seal assembly forward on shaft. Use extreme care not to mar shaft surface. Remove seal seat and rubber cup.
4. From the drive end of the bearing housing, pry out bearing seal by inserting a screwdriver blade between OD of the seal and housing. Remove retaining ring. Very carefully withdraw shaft and bearing assembly.
5. Remove inner bearing seal and retaining ring.
6. To remove bearings from shaft an arbor press is required. If an arbor press is not available then a bearing extractor may be used. Supporting inner race of bearing, apply a steady pressure on shaft until bearing slides free. Repeat this procedure to remove second bearing.

**ASSEMBLY**

1. To replace bearing on shaft. Support ball bearing on its inner race and locate shaft onto bearing. Apply a steady pressure to the shaft until bearing locates against shoulder on shaft. Repeat for second bearing.
2. Fit retaining ring and bearing seal into impeller end of bearing housing. Spring on bearing seal to face outwards.
3. Apply bearing grease around and between bearings, filling cavity between bearings two thirds full. Smear grease on shaft where bearing seal locates. Push shaft and bearing assembly into bearing housing.
4. Replace retaining ring and outer bearing seal with spring facing outwards.
5. Replace mechanical seal by sliding spacer onto shaft up to locating shoulder, then smear shaft with light lubricating oil. Push on seal gently until it engages with spacer. Fit rubber cup and seal seat into wearplate.
6. Insert impeller in pump body, fit O-ring in each end of

**EXPLODED VIEW**

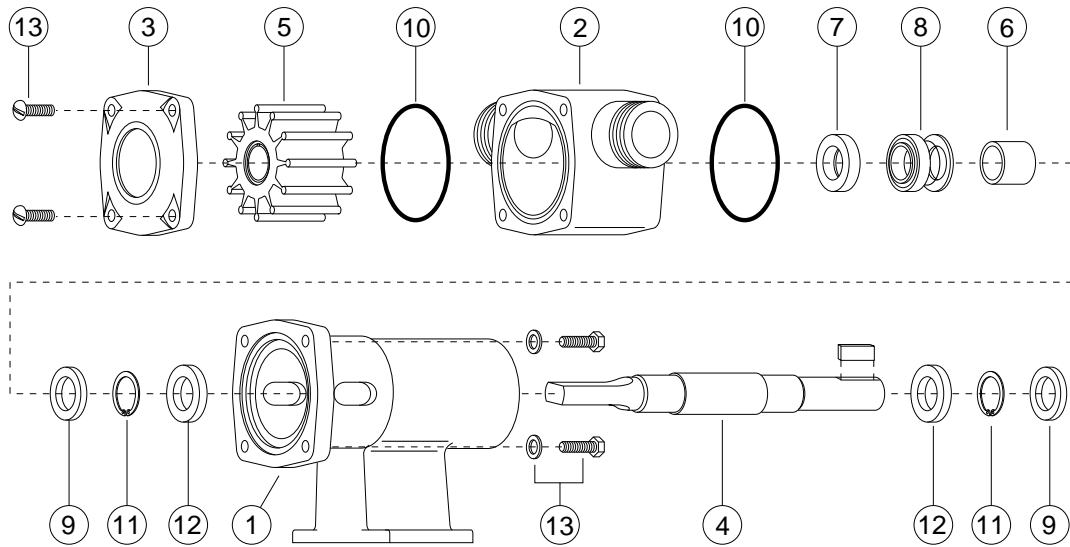

**PARTS LIST**

Key	Description	Qty.	Part Number
1	Bearing Housing	1	18753-0184
2	Body	1	18753-0190
3	End Cover	1	18753-0196
4	Shaft	1	18753-0206
5	Impeller:	1	
	Standard Pressure – Neoprene		14282-0001
	Standard Pressure – Nitrile		14282-0003
	Standard Pressure – Viton		14282-0004
	Standard Pressure – EPDM		8981-0002
	High Pressure – Neoprene		8840-0005
	High Pressure – Nitrile		8840-0006
	High Pressure – Viton		8840-0004
	High Pressure – EPDM		8840-0002
6	Spacer:	1	18753-0225
7	Seal Seat:	1	
	Nitrile		18753-0235
	Ceramic Viton		18753-0236
8	Seal Mech.:	1	
	Carbon – Nitrile		18753-0245
	Carbon – Viton		18753-0246
	Tungsten Carbide – Nitrile		18753-0247
	Tungsten Carbide – Viton		18753-0248
9	Bearing Seal	2	18753-0258
10	O-Ring:	2	
	Nitrile		18753-0263
	Viton		18753-0264
11	Retaining Ring	2	18753-0270
12	Bearing	2	18753-0274
13	Screw Kit:	1	18753-0283
	consists of		
	Screws, Hex Hd. M6 x 20mm (4)		
	Screws, Pan Hd. M6 x 20mm (4)		
	Washers, Flat M6 (4)		

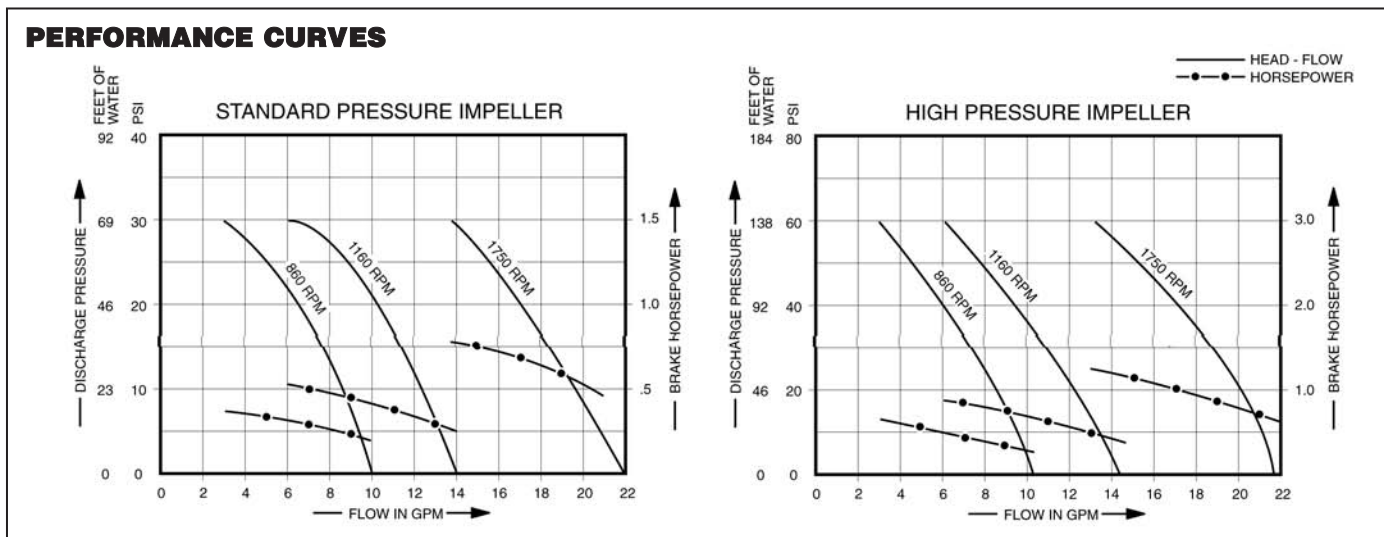
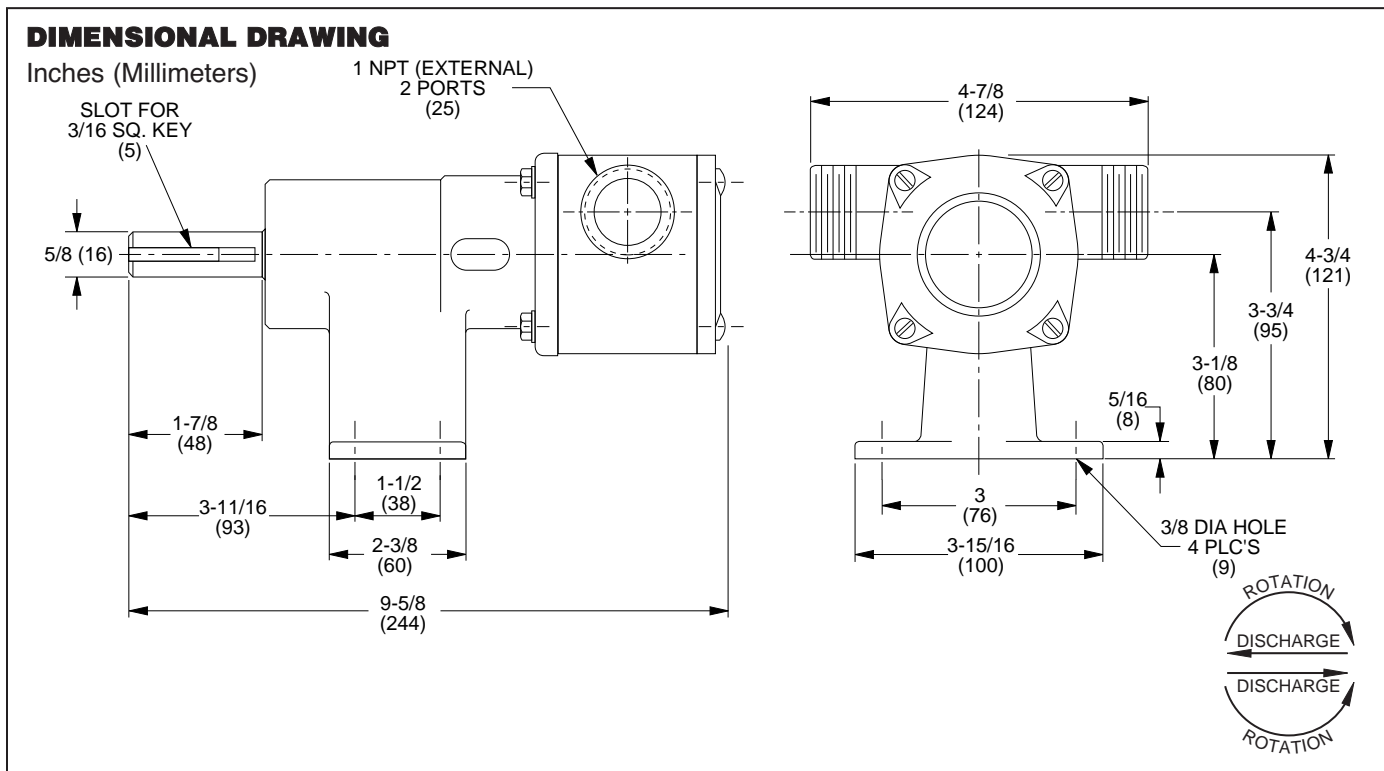

NOTE: Curves show approximate head-flow for new pumps with neoprene impeller pumping water. Capacities should be reduced approximately 10% with nitrile standard pressure impellers and approximately 15% for high pressure Viton and EPDM impellers.

Consult factory for specific performance information.

THE PRODUCTS DESCRIBED HEREIN ARE SUBJECT TO THE JABSCO ONE YEAR LIMITED WARRANTY, WHICH IS AVAILABLE FOR YOUR INSPECTION UPON REQUEST.

www.xylemflowcontrol.com

Jabscop, 100 Cummings Center, Ste. 535-N, Beverly, MA 01915  
Tel: +1 978 281 0440 Fax: +1 978 283 2619

Jabscop, Bingley Road, Hoddesdon, Hertfordshire, EN11 0BU  
Tel: +44 (0) 1992 450 145 Fax: +44 (0) 1992 467 132

NHK Jabscop Co Ltd, 3-21-10, Shin - Yokohama Kohoku-ku, Yokohama 222  
Tel: +81 (0) 45 475 8906 Fax: +81 (0) 45 475 8908

Jabscop GmbH, Oststraße 28, 22844 Norderstedt  
Tel: +49 (0) 40 53 53 73 0 Fax: +49 (0) 49 53 53 73 11

Jabscop Italia, s.r.l., Via Tommaseo, 6, 20059 Vimercate, Milano  
Tel: +39 039 685 2323 Fax: +39 039 666 307

USA

UK

JAPAN

GERMANY

ITALY



a xylem brand