

**JABSCO® PUMPS**  
 Self-Priming Pumps

**MODELS: 2187-0321 32VoltsD.C.**  
**2187-110 1110Volts D.C.**

11810

Product Data

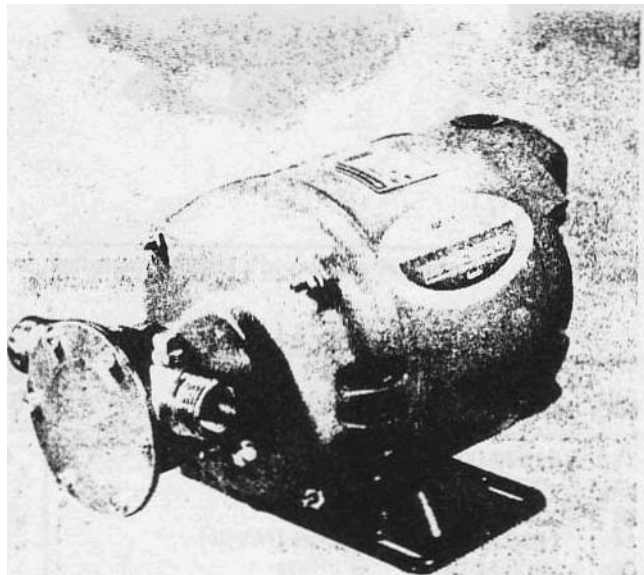

Model: 2187-0321

DESIGN FEATURES

- Body: Bronze
- Impeller: **Jabsco Nitrile** Compound
- Wearplate: Replaceable
- Shaft Seal: Rotary Type Carbon Face  
Replaceable Seal Seat
- Ports: **3/4" Garden Hose**  
Thread and **1/2" Internal Pipe** Thread
- Weight: 38 lb. (Approximately) 117,3 Kg)
- Motor: **1/4 H. P. 1725 RPM**  
32 Volt **D.C.:** 6.0 AMP;  
110 Volt D.C.: 2.8 AMP Open Flow

APPLICATIONS

Ideal for bilge pumping, Bait **tank**, Wash downs; and General Marine Service

HEAD CAPACITY TABLE

Lbs. per sq. in.	Kg per sq. em.	TOTAL HEAD		1725 RPM	
		Fl. of Water	Met" s of Water	GPM	Liters per sec.
4.3	.3	10	3	9.5	.6
8.7	.6	20	6.1	7.6	.48
13.0	.9	30	9.1	6.0	.38
17.3	1,2	40	12.2	4,2	,26

OPERATING INSTRUCTIONS

1. **INSTALLATION**- Pump may be mounted in any position without loss of efficiency; however, it is suggested that the pump head be down if vertical mounting is desired. The rotation of the motor shaft determines the location of the pump's intake and discharge ports. Refer to Dimensional Drawing.
2. **DRIVE**-Direct.
3. **SELF-PRIMING**-Pump will produce a suction lift approaching 15 feet when dry, and a lift up to 22 feet when primed. BE SURE SUCTION LINES ARE Airtight or pump will not self-prime.
4. **RUNNING DRY**-Unit depends on liquid pumped for lubrication. DO NOT RUN DRY for more than 30 seconds. Lack of liquid will burn the impeller.
5. **CAUTION**-Do not pump solvents, thinners, highly concentrated or organic acids. It corrosive fluids must be handled, pump life will be prolonged if flushed with water after each use or after each work day. MOTOR IS NOT EXPLOSION PROOF.
6. **PRESSURES**-For continuous operation, pressure should not exceed 20 PSI for either the 2187-0321 or 2187-1101.
7. **TEMPERATURE**-Impeller supplied in pump is recommended for liquid temperatures of 50° - 180° F.
8. **SPARE PARTS**- To avoid costly shut downs, keep a Jabsco Service Kit on hand.

**JABSCO PRODUCTS**



Marine and Recreation Components Division  
 International Telephone and Telegraph Corporation  
 1485 Dale Way, Costa Mesa, California 92626

Telephone: (714) 545-8251

EXPLODED VIEW

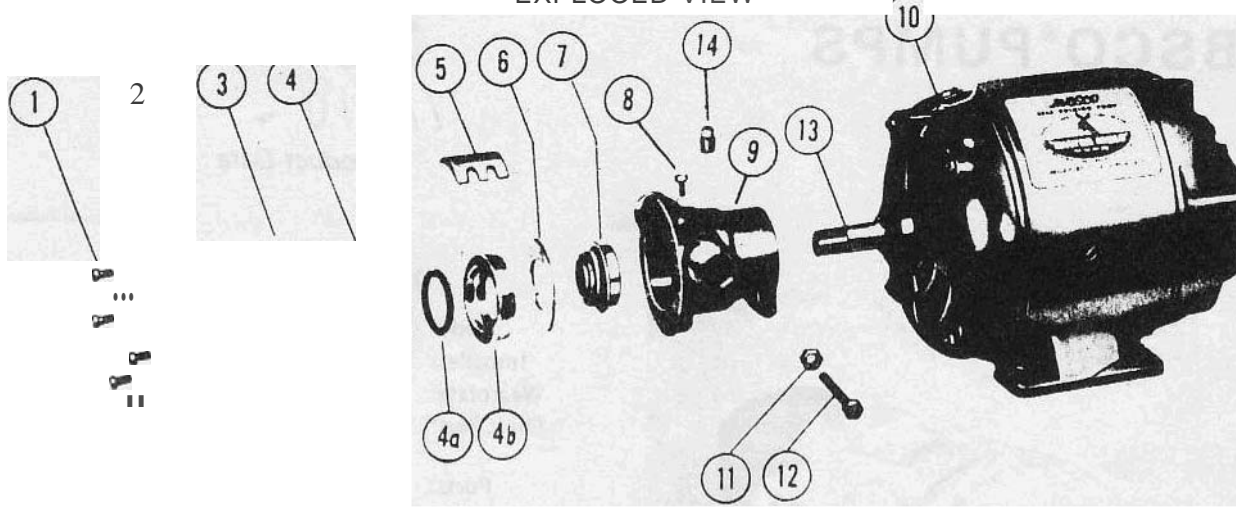

Insist on **genuine Jabsco** parts - made only by Jabsco Products ITT - the original and world's leading manufacturer of **self-priming flexible** neoprene impeller pumps.

SERVICE INSTRUCTIONS

DISASSEMBLY

1. Remove end cover screws, gasket, and end cover.
2. Withdraw impeller and seal seat assembly.
3. Loosen cam screw and remove cam. Clean off Permatex. Remove wearplate with screwdriver or hooked wire.
4. Loosen nut at body clamp. Remove body from motor spud.
5. Press seal out of body towards impeller bore.
6. Split slinger along shaft keyway and remove.

ASSEMBLY

1. Install slinger and position  $\frac{1}{4}$ " from boss.
2. Permatex I. D. of seal case. Use  $\frac{1}{2}$ " pipe size short nipple to press seal in body seal bore.
3. **Install** wearplate, aligning slot with dowel pin.
4. Permatex top of cam and cam screw threads. Install cam and secure with cam screw. making sure cam is flush with end cover surface.
5. **Install** body on motor. Tighten nut at clamp, just tight enough to prevent body from turning. Do not over-tighten or motor bearings **will** be **damaged**.
6. Lubricate impeller bore with grease.
7. Lubricate shaft O. D. with grease, align ding in impeller with keyway in shaft and install impeller and seal seat assembly. Caution: The polished seal seat of the **impeller** assembly must be handled carefully to avoid scratching.
8. Install gasket, end cover, and end cover screws.

PARTS LIST

KEY	NEW PART NUMBER	DESCRIPTION	QTY. REQ.
1	91003-0010	Screws (End <b>Cover</b> )	6
2	2236-0000	End Cover	1
3	• 2241-0000	Gasket	1
4	• 2232-0003	Impeller (Nitrile)	1
4,	9200(.0120	"O" Ring	1
4b	3023-0000	Seal Seat	1
5	490-0000	C,m	1
6	2235-0000	Wearplate	1
7	92700-0020	Seal	1
8	91003-0010	Screw (Cam)	1
9	223Q.0000	Body	1
10	93004-0570	Motor, 32 volts, D.C.	1
	93004-0450	MOlor, 110 volts, D.C.	1
11	91105-0030	Nut	1
12	91095-0090	Bolt	1
13	2398-0000	Slinger	1
14	9265(.0070	Plug (for vacuum switch hole)	1
	4008-0003	Complete Pump Head	1
	90018-0003	Service Kit (Not Shown)	1

•Parts contained in Service Kit.  
2232-0001 Neoprene Impeller available upon request from factory.

DIMENSIONAL DRAWING

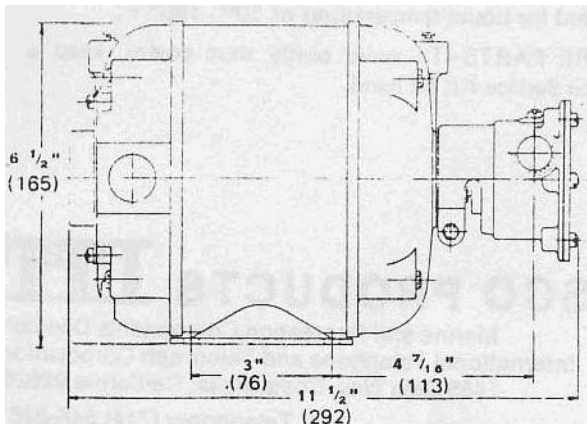

(millimeter equivalent)

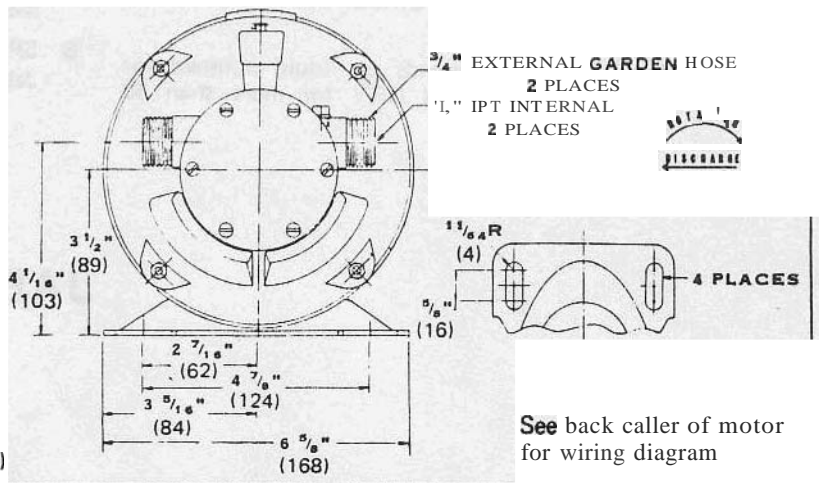

See back caller of motor for wiring diagram

---

For technical advice or service please take your pump into your local pump service center.  
To order pump or parts or for pricing please go to the following links :

[Jabsco Pumps Home >>](#)

[Jabsco Pumps stock list >>](#)