

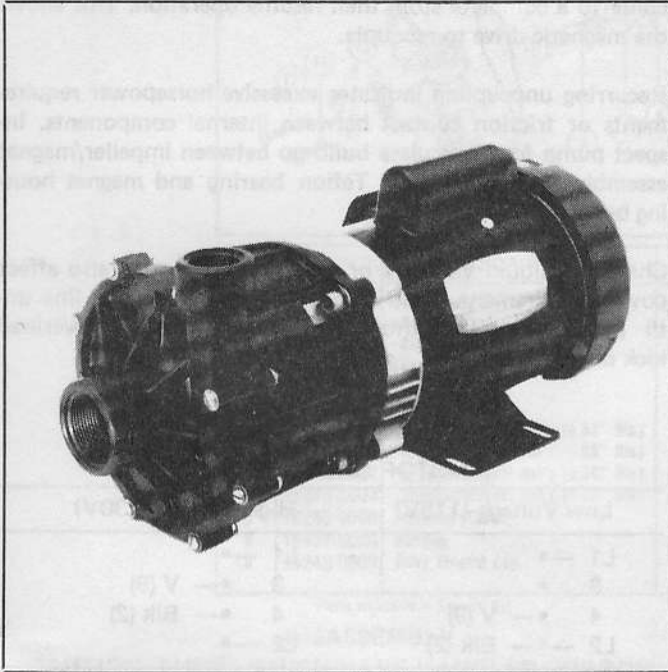

# Model 18630-SERIES

Model 18630-SERIES



## Seal-less Magnetic Drive Centrifugal Pumps

### FEATURES

**Pump Material:** Glass-filled epoxy plastic suitable for temperatures to 200° F (93°C)

**Impeller Design:** Enclosed 4.50" Dia. - 1 ½ hp  
 4.35" Dia. - 1 hp  
 4.00" Dia. - ¾ hp  
 3.50" Dia. - ½ hp

**Magnetic Drive:** Magnets enclosed in a molded epoxy cup. Minimum decoupling torque is 40 in. lbs.

**Ports:** Suction 1 ½" NPT Internal  
 Discharge 1" NPT Internal

**Motors:** Totally enclosed fan cooled, NEMA 56J C-face, 115/230 Vac, Single Phase, 60 Hz, 3450 RPM, Ball Bearing, Class B Insulation, Thermal Overload Protected.

**Weight:**

1 ½ hp TEFC	41.5 lbs (18,8 kgs)
1 hp TEFC	34.5 lbs (15,6 kgs)
¾ hp TEFC	34.5 lbs (15,6 kgs)
½ hp TEFC	31.5 lbs (14,3 kgs)



### STANDARD MODELS

IMPELLER SIZE	MOTOR HP	MOTOR PUMP UNIT
4.50" Dia.	1 ½	18630-0007
4.35" Dia.	1	18630-0001
4.00" Dia.	¾	18630-0003
3.50" Dia.	½	18630-0005

### APPLICATIONS

Seal-less magnetic drive centrifugal motor pump units are designed to handle corrosive liquids without concern for selection of exotic mechanical shaft seal materials or leakage of expensive or dangerous fluids between shaft and housing.

Highly corrosive chemicals or caustic solutions compatible with glass-filled epoxy plastic may be transferred or circulated. All parts in contact with fluid are glass-filled epoxy plastic, Ryton\*, ceramic or graphite filled Teflon\*. A Viton\* O-ring gasket is also used.

Chemicals such as alcohols, benzene, hexane, chlorinated hydrocarbons, ether compounds, fatty acids, hydrochloric acid, phosphoric acid, tannic acid, carbolic acid, sodium hydroxide, sodium nitrate, potassium hydroxide, ammonium hydroxide, toluene, trichloroethylene, lacquers, etc., may be

handled. For a more complete list of liquids compatible with epoxy plastic, consult the Jabsco Chemical Resistance Table (available upon request from ITT Jabsco) or contact the factory.

Typical applications include transfer, circulation or filtration of photo chemicals, etching solutions, plating baths, laboratory systems, processing, transfer and application of agricultural chemicals, fume scrubbing, circulation, and exotic metal recovery processes.

**WARNING: THE TEFC MOTOR IS NOT SUITABLE FOR ENVIRONMENTS WHERE FLAMMABLE VAPORS ARE PRESENT. IF USED, EXPLOSION MAY RESULT.**

Ryton\* is a trademark of Phillips Petroleum Company.

Teflon\* and Viton\* are trademarks of E. I. Du Pont de Nemours and Company.

**INSTALLATION**

**LOCATION** — Pumps with TEFC motors must be mounted in the horizontal position. Volute body may be removed and rotated to any one of eight different port positions to simplify piping. It is prudent, however, to install body and piping to eliminate possibility of air pockets in either the suction or discharge passages. **THIS PUMP WILL NOT SELF-PRIME!** If the pump is to be mounted above the liquid level, provisions must be made prior to starting pump to assure that the suction line and pump cavity are flooded.

To prevent cavitation and obtain maximum service life, it is important that suction line is free of restrictions and sharp bends. Factory application engineering assistance is available.

**WARNING: EXCESSIVE PRESSURE MAY CAUSE PUMP HOUSING FAILURE. SEVERE PERSONAL INJURY OR DEATH MAY OCCUR. DO NOT ALLOW OUTLET PRESSURES TO EXCEED 40 psi (2,8 kg/cm<sup>2</sup>).**

**PLUMBING** — All piping to the pump must be supported independent of the pump. Keep suction and discharge piping as free of elbows and bends as possible. To assure optimum performance, piping to suction port should be the same size as suction port and be straight for a minimum length of 12" without elbows or reducers.

**NOTICE:** Use only plastic fittings in the suction and discharge ports. Use Teflon tape or Loctite PST\* pipe sealant to seal threads. Do not overtighten. Damage to pump may result if disregarded.

Suction line must be airtight to maintain prime. A flap type foot valve at the suction intake or a check valve in the discharge line may be installed to retain liquid in a system during shut-down. Auxiliary priming and drain lines may be installed by drilling and tapping the surfaces provided on the volute face (see dimensional drawing).

**WIRING** — Consult the motor wiring connection diagram below or motor label for 115 Vac or 230 Vac motor connection.

**OPERATION** — Pump must be primed to begin pumping operation. Do not operate pump dry.

If pumping action ceases during normal operation and the motor continues to run, uncoupling of magnetic drive has occurred. Disconnect power to the motor, let pump motor come to a complete stop, then resume operation. This allows the magnetic drive to recouple.

Recurring uncoupling indicates excessive horsepower requirements or friction contact between internal components. Inspect pump for particulate build up between impeller/magnet assembly inside diameter, Teflon bearing and magnet housing boss.

Change in liquid viscosity or specific gravity may also affect power requirement. Restrict flow through discharge line until pump operates without uncoupling or motor overload kick out occurring.

**MOTOR CONNECTIONS**

Low Voltage (115V)	High Voltage (230V)
L1 —•	L1 —•
3 •	3 •— V (9)
4 •— V (9)	4 •— Blk (2)
L2 —•— Blk (2)	L2 —•

**DIMENSIONAL DRAWING  
INCHES (MILLIMETRES)**

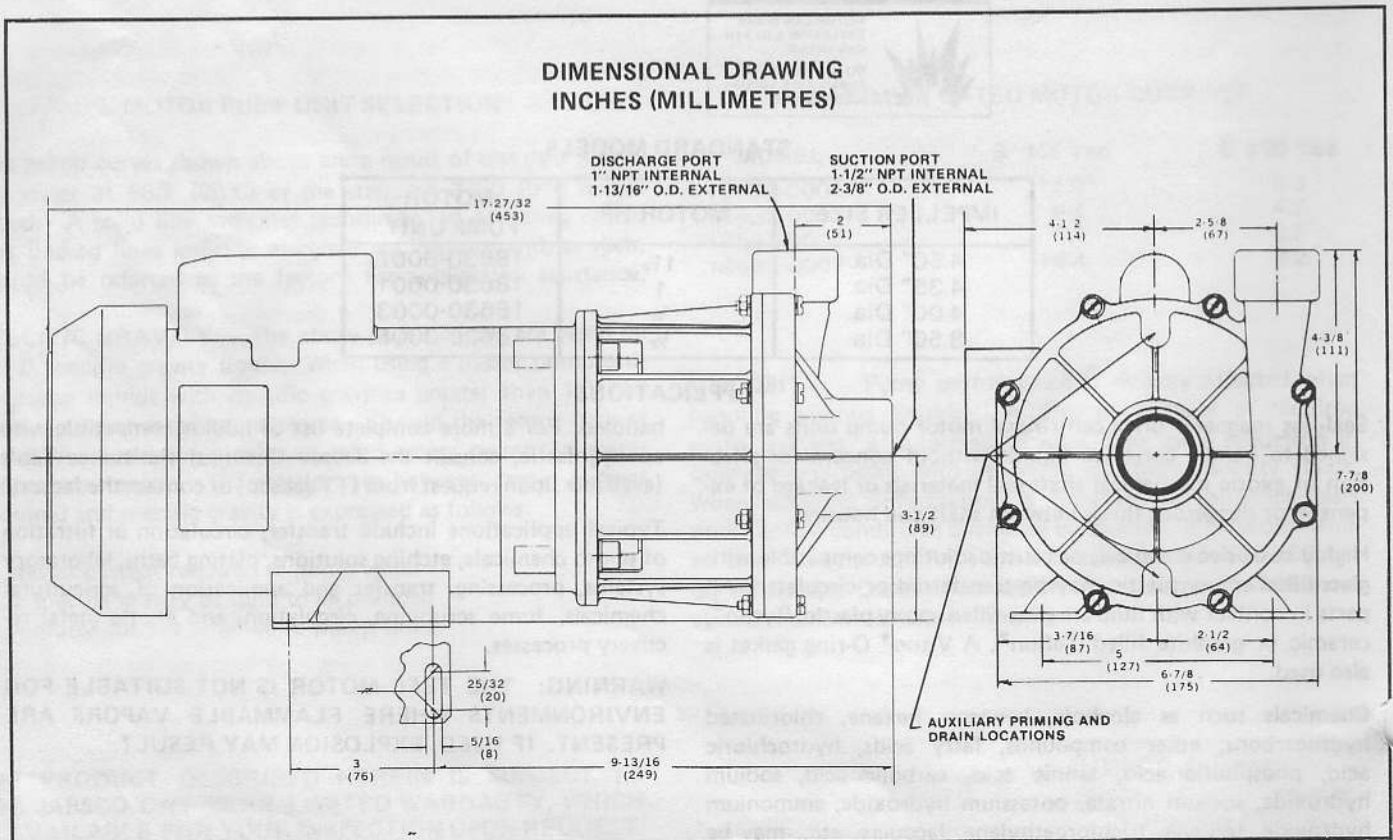

Loctite PST\* is a trademark of Loctite Corporation.

---

For technical advice or service please take your pump into your local pump service center.  
To order pump or parts or for pricing please go to the following links :

[Jabsco Pumps Home >>](#)

[Jabsco Pumps stock list >>](#)