

JABSCO® PRODUCTS

Seal-less Magnetic Drive Centrifugal Pumps

MODEL 18230-Series

Motor Pump Units

PRODUCT DATA

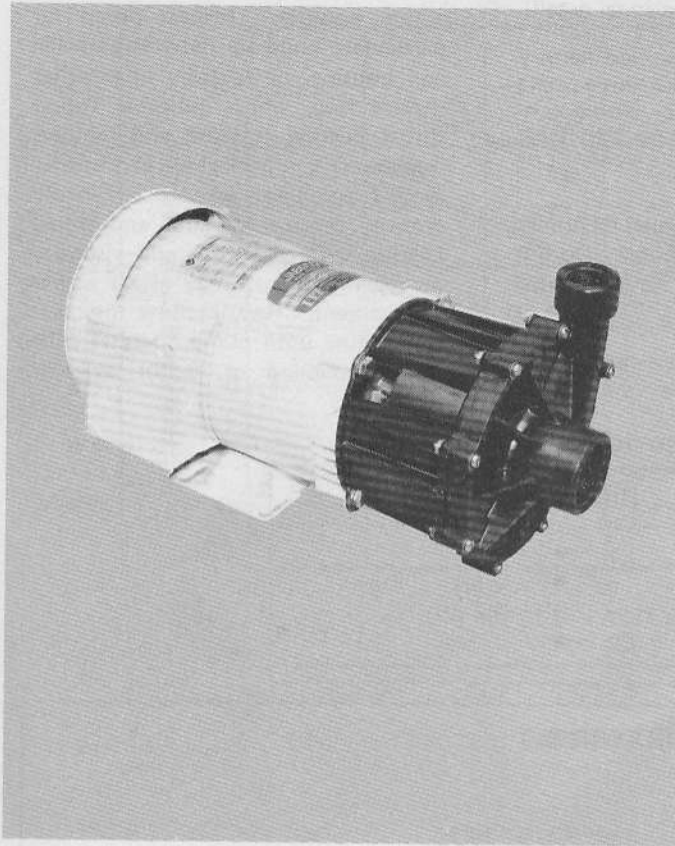

DESIGN FEATURES

CORROSION RESISTANT

Pump Material: Glass Filled Epoxy Plastic Suitable for Temperatures to 200° F. (93° C)

Impeller Design: Enclosed 4.35" Dia. — 1 HP
4.0 Dia. — ¾ HP
3.5 Dia. — ½ HP

SEAL-LESS

Magnetic Drive: Magnets enclosed in a molded epoxy cup. No Contact With Liquid Being Pumped

Ports: Suction 1½" NPT Internal
Discharge 1" NPT Internal

Motors: Open Drip Proof or T.E.F.C.
NEMA "C" Face, 115/208/
230 VAC

Single Phase, 60 Cycle, 3450 RPM
Ball Bearing, Class B Insulation
Thermal Overload Protected. Wired for 115 VAC and Supplied With 6 foot Cord With 3 Prong Plug.

Weight:

1 HP	Open	32.5 lbs. (14.7 Kgs)
	TEFC	34.5 lbs. (15.6 Kgs)
¾ HP	Open	32.5 lbs. (14.7 Kgs)
	TEFC	34.5 lbs. (15.6 Kgs)
½ HP	Open	29.5 lbs. (13.4 Kgs)
	TEFC	31.5 lbs. (14.3 Kgs)

MODEL 18230-SERIES

STANDARD MODELS

Impeller Size	Motor HP	MOTOR TYPE	
		OPEN	TEFC
4.35	1	18230-0000	18230-0001
4.00	¾	18230-0002	18230-0003
3.50	½	18230-0004	18230-0005

APPLICATIONS

Seal-less magnetic drive motor pump units are designed to handle corrosive liquids without concern of selection of exotic mechanical shaft seal materials or leakage of expensive or dangerous fluids between shaft and housing.

Highly corrosive chemicals or caustic solutions compatible with glass filled epoxy plastic may be transferred or circulated. All parts in contact with fluid are glass filled epoxy plastic or graphite filled teflon.

Chemicals such as Alcohols, Benzene, Hexane, Chlorinated hydrocarbons, Ether compounds, Fatty acids, Hydrochloric acid, Phosphoric acid, Hydrofluoric acid, Tannic acid, Carboic

acid, Sodium hydroxide, Sodium nitrate, Potassium hydroxide, Ammonium hydroxide, Toluene, Trichloroethylene, Laquers, etc... may be handled. For a more complete list of liquids compatible with epoxy plastic, consult the Jabsco Chemical Resistance Table or the factory.

INDUSTRIAL AND OEM

Transfer, circulation or filtration of photo chemicals, etching solutions, plating baths, laboratory systems, processing, transfer and application of agricultural chemicals, fume scrubbing, circulation, and exotic metal recovery processes are typical applications.

INSTALLATION

LOCATION — Pumps with TEFC motors may be mounted in any position. Pumps with open drip-proof motors should be suitably mounted to prevent moisture from entering motor. Volute may be removed and rotated to any one of eight different port positions to simplify piping. If the pump is to be mounted above the liquid level, provisions must be made to assure that the suction line and, pump cavity is flooded before starting pump.

JABSCO PRODUCTS ITT

INSTALLATION (Cont'd)

THIS PUMP WILL NOT SELF PRIME!
To prevent cavitation and obtain maximum service life, it is important that suction line is free of restrictions and sharp bends. Factory application engineering assistance is available.

NOTE: For inlet pressure over 20 PSI, consult the factory for assistance.

PLUMBING — All piping to the pump must be supported independently of the pump. **CAUTION:** Use only plastic fittings in the suction and discharge ports. Keep suction and discharge lines as free of elbows and bends as possible. To assure optimum performance, suction port line should be straight for a minimum length of 12" without elbow or reducers.

Suction line must be air tight to maintain prime. A flap type foot valve at the suction intake or a check valve in the discharge line may be installed to retain liquid in system during shut-down. An auxiliary prime line may be installed by drilling and tapping boss on volute face (see dimensional detail).

WIRING — Pump motors are factory wired with a 115 VAC three-prong plug. Consult the motor wiring connection diagram below for 230 VAC motor connection.

OPERATION — Pump must be primed to begin pumping operation. Do not operate pump dry for extended periods.

If pumping action ceases during normal operation and the motor con-

tinues to run, disconnect power to the motor. Let pump motor come to a complete stop, then resume operation, this allows the magnet to "recouple".

Recurring uncoupling indicate excessive horsepower requirements or friction contact between impeller and volute housing. Inspect pump for particulate build up between impeller and housing, or scuffing of impeller shroud face, which indicates Teflon thrust bearing is worn and requires replacement. Check track on impeller shroud for wear groove. If badly grooved replace impeller and thrust bearing. Change in liquid viscosity or specific gravity may affect power requirement. Restrict flow thru discharge line until pump operates without uncoupling or motor overload kick out.

MOTOR CONNECTIONS

LOW VOLTAGE (115V)	HIGH VOLTAGE (230V)
L1 ●	L1 ●
3 ●	● V (9)
4 ● V (9)	● Blk (2)
L2 ● Blk (2)	L2 ●

DIMENSIONAL DRAWING

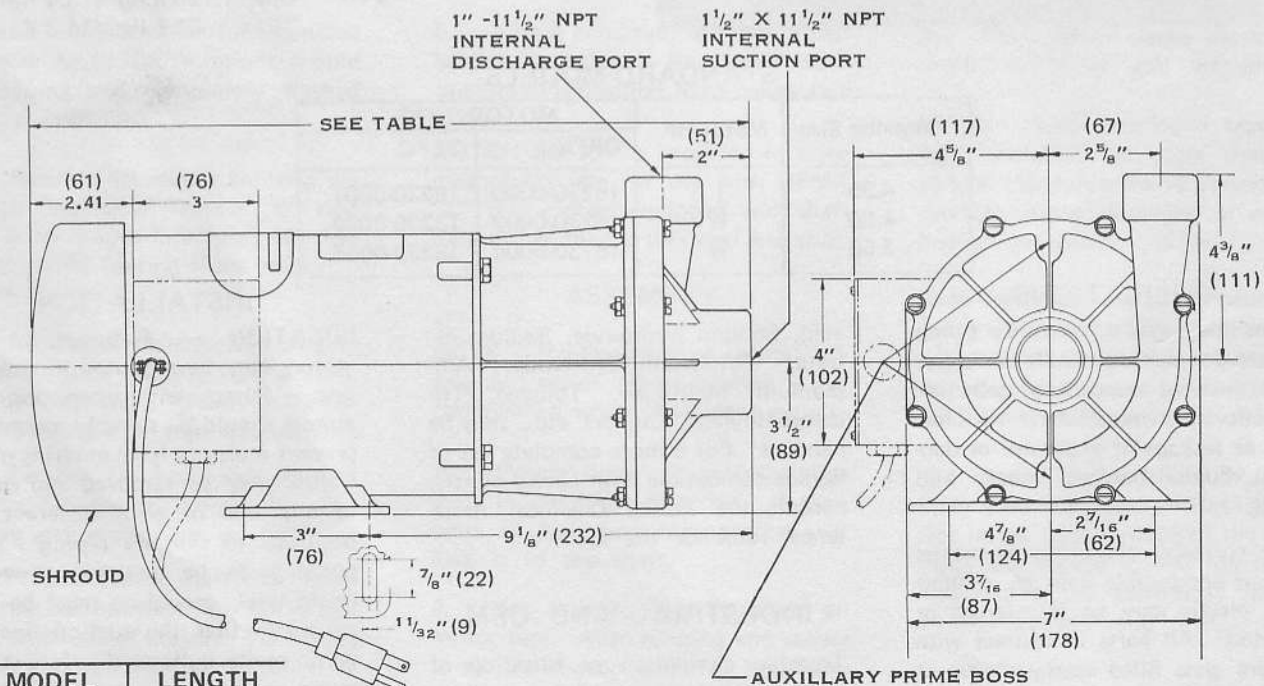

(Millimeter Equivalent)

For technical advice or service please take your pump into your local pump service center.
To order pump or parts or for pricing please go to the following links :

[Jabsco Pumps Home >>](#)

[Jabsco Pumps stock list >>](#)