

JABSCO® PUMPS

Self-Priming Pumps



MODELS 1673-0001 (Lip Seal) 1673-9001 (Face Seal)

PRODUCT DATA

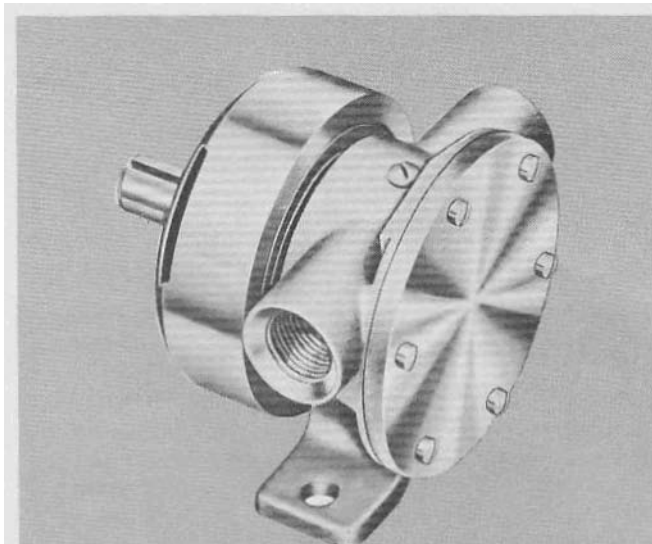

Other JABSCO models are also available in bronze, plastic, cast iron and stainless steel. JABSCQ Pureflo pumps are also available for **sanitary** applications.

DESIGN FEATURES

| | |
|-------------|--|
| Body: | Bronze |
| Impeller: | Neoprene, Nitrile or Polyurethane |
| Shaft: | Brass with Face Seal Stainless Steel with Lip Seal |
| Bearings: | Shielded Ball Bearing |
| Shaft seal: | Mechanical Face Seal or Lip Seal |
| Ports: | ½" NPT |
| Weight: | 4¼ lbs. (2 kg.) approx. |

VARIATIONS AVAILABLE

| MODEL | VARIATIONS INCORPORATED |
|-----------|---|
| 1673-9051 | Half Thickness Cam-Face Seal (Where reduced capacity is required with a fixed speed) |
| 1673-9003 | Nitrile Impeller-Face Seal (Oil Resistant) |
| 1673-0003 | Nitrile Impeller-Lip Seal (011 Resistant) |
| 1673-0007 | Polyurethane Impeller-Lip Seal (Handles certain dry cleaning solutions, chlorinated glues and refrigeration coil cleaners) |

APPLICATIONS & OPERATING INSTRUCTIONS

MARINE: Pumping bilges, Wash-downs, Circulating water in bait tanks, Utility dock side pump, Engine cooling.

INDUSTRIAL: Circulating and transferring, Velocity-mixing, Pumping machine tool coolants, Return **spill**, Sump drainage, Chemicals, Pharmaceuticals, Soap, Liquors, Ink, Dyes, Alcohol, Various acids, Tanning liquors, Glycerine, Brine, etc.

FARMING: Pumping water for stock, Pumping water from shallow wells and cisterns. Pumping liquid ballast into tractor tires.

PLUMBING & HOME EMERGENCY USE: Pumping out flooded basements, Cesspools, Sumps, Water heaters and water closets, Drains and sinks, Draining fishponds and pools.

1. **INSTALLATION**-Pump may be mounted in any position. Intake and discharge ports are deter-

mined by the direction of shaft rotation (refer to Dimensional Drawing). Before installing, turn the pump shaft in the direction of the operating rotation.

2. **DRIVE**-Belt or Direct with flexible coupling.

CAUTION: Do not press a pulley or coupling on the shaft without supporting the shaft to prevent movement of the shaft into the impeller bore.

Belt Drive-Overtight belt load will reduce pump bearing life.

Direct Drive- Clearance should be left between drive shaft and pump shaft when installing coupling. Always mount and align pump and drive shaft before tightening the coupling set screw.

3. **SPEEDS**-100 RPM to the maximum shown in the performance

table. Consult the factory for operation at speeds above those shown. For longer pump life, operate at lowest possible speeds.

4. **SELF-PRIMING**-Primes at low or high speeds. For vertical dry suction lift of 10 feet (3m) a minimum of 800 RPM is required. Pump will produce suction lift up to 22 feet (6m) when welled. **BE SURE SUCTION LINES ARE AIRTIGHT OR PUMP WILL NOT SELF-PRIME.**

5. **RUNNING DRY**-Unit depends on liquid pumped for lubrication. **DO NOT RUN DRY** for more than 30 seconds. Lack of liquid will burn the impeller.

6. **CAUTION**- If pumping **light** fraction petroleum derivatives, solvents, thinners, highly concentrated or organic acids, consult Jabsco "Chemical Resistant

(continued)

JABSCO PRODUCTS



Form 43000-0077 Rev. 8-76

OPERATING INSTRUCTIONS (Cant.)

Table" for proper body materials and impeller compounds. If corrosive fluids are handled, pump life will be prolonged. if flushed with water after each use or after each work day.

7. PRESSURES- Consult Head Capacity Table for recommended maximum for continuous operation. If pressures exceed those shown, consult the factory.

8. TEMPERATURES-

Neoprene 4So-180oF (7°-82°CI
Nitrile 50°-180°F (10°-82°C)
Polyurethane 45°-120°F (70-49°CI
9. FREEZING WEATHER-Drain unit by loosening end cover. The following anti-freeze compounds can be used without any adverse effects to the neoprene impeller: Atlas "Permaguard", DuPont "Zarex" and "Telar", Dow Chemical "Oowguard" and Olin Mathison "Pyro Permanent". Most Methyl alcohol

(methanol) based anti-freeze can be used with neoprene. DO NOT USE PETROLEUM BASED ANTI-FREEZE COMPOUNDS OR RUST INHIBITORS.

10. GASKET-Use a standard pump part. Thicker gasket will reduce priming ability. A thinner gasket will cause the impeller to bind. Standard gasket is .010" thick.

11. SPARE PARTS-To avoid costly shut downs, keep-a JABSCO Service Kit on hand.

EXPLODED VIEW

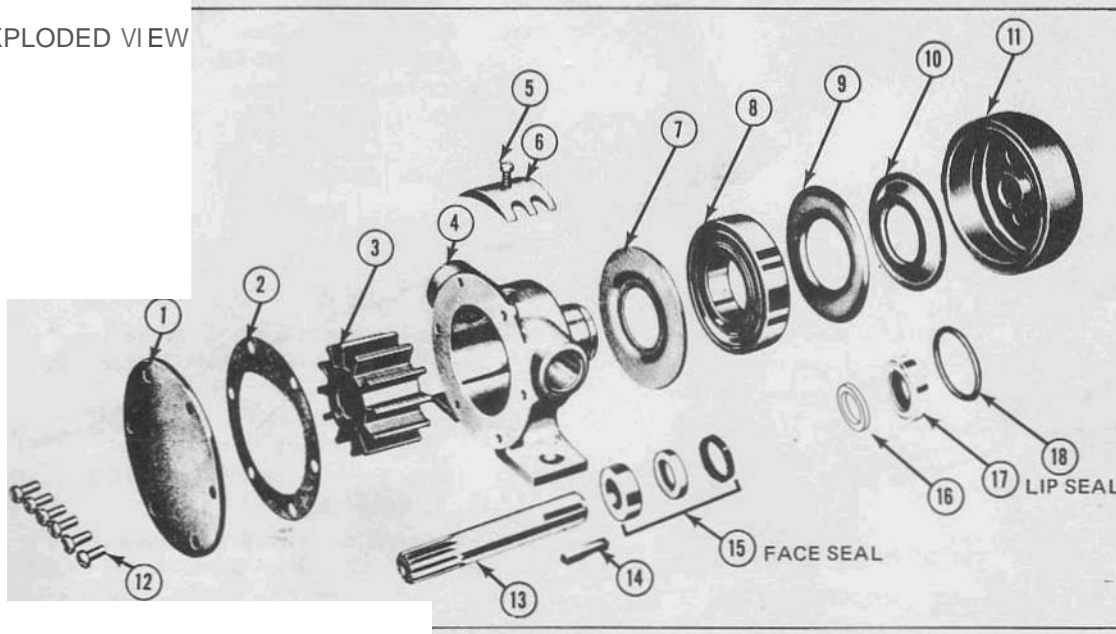

PARTS LIST

| KEY | DESCRIPTION | 1673-9001 | 1673-0001 | QTY. |
|-----|-------------------------|----------------------------------|---------------------------------|------|
| | | Face SuI versions PART NUMBER | Lip Sui ve. ions PART NUMBER | |
| 1 | End Cover Standard | 1743-9000 | 1743-0000 | 1 |
| | Nitrile version | 1743-9370 | 1743-0370 | |
| | Polyurethane version | - | 1743-0860 | |
| | Half-Cam version | 1743-9050 | - | |
| 2 | Gasket Standard | 1835-0000 | 1835-0000 | 1 |
| | Half-Cam version | 2436-0000 | - | |
| 3 | Impeller Neoprene | 1210-0001 | 1210-0001 | 1 |
| | Nitrile | 1210-0003 | 1210-0003 | |
| | Polyurethane | - | 1210-0007 | |
| 4 | Key | 9094-0000 | 9094-0000 | 1 |
| 5 | Screw (Cam) Standard | 91003-0010 | 91003-0010 | 1 |
| | Half-Cam version | 91003-0090 | - | |
| 7 | Cam-Standard Plastic | 490-0000 | 490-0000 | 1 |
| | Optional B.u. | 490-000 | 490-0004 | |
| | Half-Cam-Brass | 2434-0000 | - | |
| 8 | Bearing Shield | 3078-0000 | 3078-0000 | 1 |
| 9 | Ball Bearing | 92600-0330 | 92600-0330 | 1 |
| | Rotating Shield | 1161-0000 | 1161-0000 | 1 |
| 10 | Stationary Silnge. | 1554-0000 | 1554-0000 | 1 |
| 11 | Bearing Housing | 1740-0000 | 1740-0000 | 1 |
| 12 | Screw (End Cover) | 91003-0010 | 91003-0010 | 1 |
| 13 | Shaft | 1737-0410 | 1737-0240 | 1 |
| 14 | Key | 9215-0010 | 9215-0010 | 1 |
| 15 | Face Seal | 96080-0080 | - | 1 |
| 16 | Spacer | - | 3166-0000 | 1 |
| 17 | Lip Seal | - | 92700-0060 | 1 |
| 18 | 1" O' Ring | - | 92000-0210 | 1 |
| | Service Kit | | | |
| | Neoprene | 90119-0001 | 90015-0001 | |
| | Nitrile Impelle. | 90119-0003 | 90015-0003 | |
| | Polyurethane Impeller | - | 90015-0007 | |

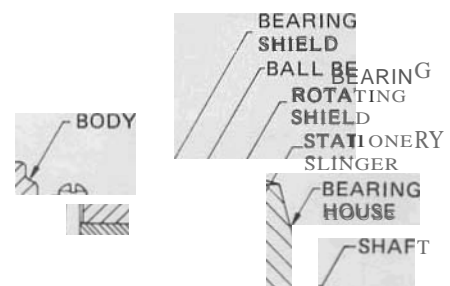

Cross Section to show relative position of bearing and slinger parts

*Pin" supplied In Service Kit

FOI Models prior to Feb. 25, 1964

SERVICE INSTRUCTIONS

DISASSEMBLY

TO CHANGE IMPELLER, FOLLOW STEPS 1 & 2.

1. Remove end cover screws, end cover and gasket.
2. Remove impeller by grasping hub with water pump pliers.
3. Loosen cam screw and remove cam (clean off Permatex).
4. Remove key from shaft.
5. Remove bearing housing from bearing (requires arbor press, gear puller and hand torch) by heating housing uniformly to 325°F. Housing will expand and may be lifted off of the bearing.
6. Supporting bearing housing on internal hub, press shaft

TO CHANGE SEAL, FOLLOW STEPS 1, 2, 5, 7 & 11.

7. Face seal version only: Remove seal seat assembly from shaft.
 - a. Remove stationary slinger and rotating shield.
9. Remove bearing from body with gear puller.
10. Remove bearing shield from body.
11. Remove seal assembly from seal bore by pressing from bearing end toward impeller bore.

Note: Inspect all parts for wear or damage and replace if necessary.

ASSEMBLY

TO INSTALL NEW IMPELLER, FOLLOW STEPS 8 & 9.

1. With bearing shield between bearing and body, press bearing on body. Press on inner race of bearing. (Ref. cross section.)
2. Install rotating shield against bearing and press stationary slinger on body. (Ref. cross section.)
3. Press shaft into bearing housing. Support housing and press keyway end through shall hole in bearing housing.

Note: When installing shaft into a used bearing housing always use the knurled replacement shaft available (::1737-0410 or #1737-0240.)
4. Heat bearing housing and shaft assembly uniformly to 325°F. and install over bearing and body assembly.

Note: Housing **will** shrink immediately upon contact with bearing, therefore, it must be positioned ("bollomed") quickly.
5. Install seal assembly on shaft against bearing hous-

TO INSTALL NEW SEAL. FOLLOW STEPS 4, 5, 6, 8 & 9.

- ing hub (gasket toward hub). Lubricate gasket with water 10 facilitate assembly. (Model 1673-9001)
6. Install seal assembly into seal bore (as applicable: Lip of lip seal facing impeller bore, or carbon face of face seal toward seal seat). Use care to press on outer most edge of seal case face 10 prevent damage to seal. Seal must be flush with back surface of Impeller bore to insure proper sealing, for face seal version. Lip seal may be positioned in seal bore to clear worn area of shaft.
7. Permatex screw threads and **top** side of cam and install in body **with** cam screw.
 - a. Lubricate impeller bore with a light coat of Marfak 2HD grease or equivalent and start impeller into bore with a rotary motion **in** the intended direction of rotation until splines engage, then pUsh into bore.
9. Install gasket and end cover and secure with end cover screws.

DIMENSIONAL DRAWING

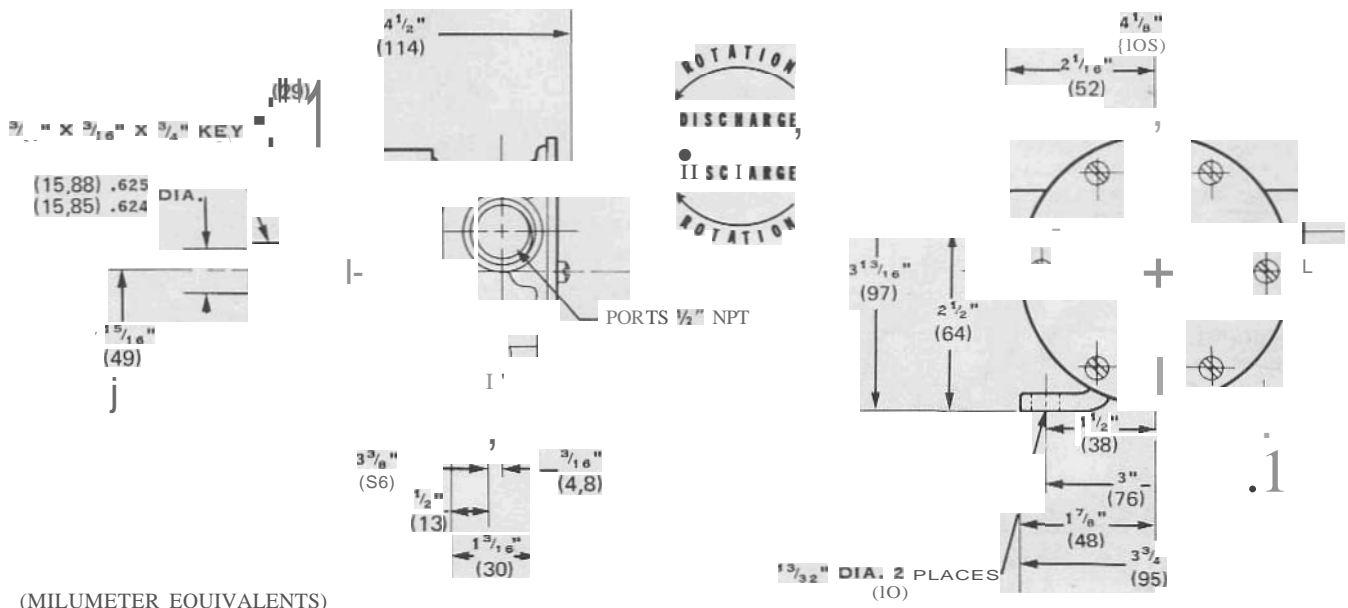

HEAD CAPACITY TABLES

16730001 & 1673 9001 NEOPRENE

| TOTAL HEAD | | 500 RPM | | 1160 RPM | | 1750 RPM | | 2100 RPM | | 2450 RPM | | 2150 R | | 3000 M | | 3600 RPM | |
|------------|--------------|---------|-----|----------|-----|----------|-----|----------|-----|----------|-----|---------|-----|---------|-----|----------|-----|
| P.S.I. | Ft. of Water | GPM | HP | GPM | HP | GPM | HP | GPM | HP | GPM | HP | GPM | HP | GPM | HP | GPM | HP |
| (kg/sq cm) | (meter) | (l/min) | | (l/min) | | (l/min) | | (l/min) | | (l/min) | | (l/min) | | (l/min) | | (l/min) | |
| 4.3 | 10 | 3.0 | 1/6 | 7.6 | 1/4 | 11.0 | 1/4 | 13.0 | 1/3 | 15.2 | 1/2 | 16.7 | 1/2 | 18.0 | 1/2 | 19.6 | 3/4 |
| (.3) | (3) | (11.3) | | (28.7) | | (41.6) | | (49.2) | | (57.5) | | (63.2) | | (68.1) | | (74.2) | |
| 8.7 | 20 | 1.8 | 1/6 | 6.4 | 1/4 | 10.0 | 1/4 | 11.5 | 1/3 | 13.7 | 1/2 | 15.4 | 1/2 | 17.0 | 1/2 | 18.8 | 3/4 |
| (.6) | (6) | (6.8) | | (24.2) | | (37.8) | | (43.5) | | (51.8) | | (55.3) | | (64.3) | | (71.1) | |
| 13.0 | 30 | | | 4.8 | 1/4 | 8.5 | 1/3 | 10.0 | 1/2 | 12.0 | 1/2 | 13.6 | 3/4 | 15.3 | 3/4 | 17.5 | 3/4 |
| (.9) | (9) | | | (18.2) | | (32.2) | | (37.8) | | (45.4) | | (51.5) | | (59.9) | | (66.2) | |
| 17.3 | 40 | | | 3.3 | 1/4 | 6.7 | 1/3 | 8.5 | 1/2 | 10.4 | 1/2 | 12.0 | 3/4 | 13.5 | 3/4 | 16.0 | 1 |
| (1.2) | (12) | | | (12.5) | | (25.3) | | (32.2) | | (39.3) | | (45.4) | | (51.1) | | (60.5) | |
| 21.6 | 50 | | | | | 5.0 | 1/2 | 6.7 | 1/2 | 8.5 | 1/2 | 10.0 | 3/4 | 11.8 | 3/4 | 14.5 | 1 |
| (1.5) | (15) | | | | | (118.9) | | (25.3) | | (32.2) | | (31.8) | | (44.6) | | (54.9) | |
| 26.0 | 60 | | | | | | | 5.0 | 1/2 | 7.0 | 3/4 | 8.3 | 3/4 | 10.0 | 3/4 | 13.0 | 1 |
| (1.8) | (18) | | | | | | | (18.9) | | (26.5) | | (31.4) | | (31.5) | | (49.2) | |
| 30.3 | 70 | | | | | | | | | | | 6.5 | 3/4 | 8.0 | 1 | 11.0 | 1 |
| (2.1) | (21) | | | | | | | | | | | (24.6) | | (30.3) | | (41.5) | |

1673-0003 & 1673-9003 NITRILE

| TOTAL HEAD | | 500 RPM | | 1160 RPM | | 1760 RPM | | 2100 RPM | | 2450 RPM | | 2750 RPM | | 3000 RPM | | 3600 RPM | |
|------------|--------------|---------|-----|----------|-----|----------|-----|----------|-----|----------|-----|----------|-----|----------|-----|----------|-----|
| P.S.I. | Ft. of Water | GPM | HP | GPM | HP | GPM | HP | GPM | HP | GPM | HP | GPM | HP | GPM | HP | GPM | HP |
| (kg/sq cm) | (meter) | (l/min) | | (l/min) | | (l/min) | | (l/min) | | (l/min) | | (l/min) | | (l/min) | | (l/min) | |
| 4.3 | 10 | 2.2 | 1/8 | 5.8 | 1/6 | 9.5 | 1/4 | 11.5 | 1/3 | 13.3 | 1/2 | 15.0 | 1/2 | 16.0 | 1/2 | 18.2 | 3/4 |
| (.3) | (3) | (8.3) | | (21.9) | | (35.9) | | (43.5) | | (50.3) | | (56.1) | | (60.5) | | (68.9) | |
| 8.7 | 20 | | | 4.3 | 1/6 | 7.6 | 1/3 | 9.1 | 1/3 | 11.4 | 1/2 | 13.0 | 1/2 | 14.4 | 1/2 | 17.0 | 3/4 |
| (.6) | (6) | | | (16.3) | | (28.7) | | (35.6) | | (43.1) | | (49.2) | | (54.5) | | (64.3) | |
| 13.0 | 30 | | | 2.5 | 1/6 | 6.0 | 1/3 | 7.4 | 1/2 | 9.3 | 1/2 | 11.0 | 1/2 | 12.6 | 3/4 | 15.3 | 3/4 |
| (.9) | (9) | | | (9.4) | | (22.7) | | (28.0) | | (35.2) | | (41.6) | | (47.7) | | (57.9) | |
| 17.3 | 40 | | | | | 1.2 | 1/2 | 1.6 | 1/2 | 2.5 | 1/2 | 3.2 | 3/4 | 4.0 | 3/4 | 5.8 | 1 |
| (1.2) | (12) | | | | | (15.9) | | (21.2) | | (28.4) | | (34.8) | | (40.9) | | (51.5) | |
| 21.6 | 50 | | | | | | | 3.9 | 1/2 | 5.7 | 3/4 | 7.2 | 3/4 | 9.0 | 3/4 | 11.7 | 1 |
| (1.5) | (15) | | | | | | | (14.7) | | (21.6) | | (27.2) | | (34.0) | | (42.3) | |
| 26.0 | 60 | | | | | | | | | 5.5 | 3/4 | 7.2 | 3/4 | 9.0 | 3/4 | 12.3 | 1 |
| (1.8) | (18) | | | | | | | | | (20.8) | | (26.9) | | (33.0) | | (41.7) | |

16739061 HALF CAM NEOPRENE

| TOTAL HEAD | | 500 RPM | | 1160 RPM | | 1750 RPM | | 2100 RPM | | 2450 RPM | | 2750 RPM | | 3000 RPM | | 3600 RPM | |
|------------|--------------|---------|-----|----------|-----|----------|-----|----------|-----|----------|-----|----------|-----|----------|-----|----------|-----|
| P.S.I. | Ft. of Water | GPM | HP | GPM | HP | GPM | HP | GPM | HP | GPM | HP | GPM | HP | GPM | HP | GPM | HP |
| (kg/sq cm) | (meter) | (l/min) | | (l/min) | | (l/min) | | (l/min) | | (l/min) | | (l/min) | | (l/min) | | (l/min) | |
| 4.3 | 10 | 1.6 | 1/6 | 4.1 | 1/6 | 6.3 | 1/4 | 7.7 | 1/3 | 9.0 | 1/3 | 10.1 | 1/2 | 11.0 | 1/2 | 13.1 | 3/4 |
| (.3) | (3) | (6.1) | | (15.5) | | (23.8) | | (29.1) | | (34.0) | | (38.2) | | (41.6) | | (49.6) | |
| 8.7 | 20 | 1.2 | 1/6 | 3.6 | 1/6 | 5.8 | 1/4 | 7.0 | 1/3 | 8.1 | 1/2 | 9.5 | 1/2 | 10.2 | 1/2 | 12.3 | 3/4 |
| (.6) | (6) | (4.5) | | (13.6) | | (22.0) | | (26.5) | | (31.8) | | (35.9) | | (38.6) | | (46.5) | |
| 13.0 | 30 | | | 3.1 | 1/6 | 5.0 | 1/3 | 6.2 | 1/3 | 7.6 | 1/2 | 8.6 | 1/2 | 9.4 | 3/4 | 11.3 | 3/4 |
| (.9) | (9) | | | (11.7) | | (18.8) | | (23.4) | | (28.7) | | (32.5) | | (35.6) | | (42.8) | |
| 17.3 | 40 | | | 2.4 | 1/6 | 1.1 | 1/3 | 1.5 | 1/2 | 2.3 | 1/2 | 3.0 | 3/4 | 3.8 | 3/4 | 5.3 | 1 |
| (1.2) | (12) | | | (9.1) | | (15.5) | | (20.0) | | (25.3) | | (29.1) | | (31.8) | | (39.0) | |
| 21.6 | 50 | | | | | 3.1 | 1/3 | 1.2 | 1/2 | 1.7 | 1/2 | 2.3 | 3/4 | 2.9 | 3/4 | 4.2 | 1 |
| (1.5) | (15) | | | | | (11.7) | | (15.9) | | (21.5) | | (25.3) | | (28.0) | | (34.8) | |
| 26.0 | 60 | | | | | | | | | 1.5 | 1/2 | 2.0 | 3/4 | 2.6 | 3/4 | 3.6 | 1 |
| (1.8) | (18) | | | | | | | | | (11.0) | | (14.2) | | (17.3) | | (21.6) | |

16730007 POLYURETHANE

| TOTAL HEAD | | 500 RPM | | 1160 RPM | | 1750 RPM | |
|------------|--------------|---------|-----|----------|-----|----------|-----|
| P.S.I. | Ft. of Water | GPM | HP | GPM | HP | GPM | HP |
| (kg/sq cm) | (meter) | (l/min) | | (l/min) | | (l/min) | |
| 4.3 | 10 | 3.2 | 1/4 | 7.9 | 1/3 | 11.8 | 1/2 |
| (.3) | (3) | (12.1) | | (29.9) | | (44.6) | |
| 8.7 | 20 | 3.0 | 1/4 | 7.7 | 1/3 | 11.6 | 1/2 |
| (.6) | (6) | (11.3) | | (29.1) | | (43.9) | |
| 13.0 | 30 | 2.5 | 1/4 | 7.3 | 1/2 | 11.0 | 1/2 |
| (.9) | (9) | (9.4) | | (27.6) | | (41.6) | |
| 17.3 | 40 | 1.8 | 1/4 | 6.5 | 1/2 | 10.0 | 3/4 |
| (1.2) | (12) | (6.8) | | (24.6) | | (37.8) | |
| 21.6 | 50 | | | 5.4 | 1/2 | 8 | 3/4 |
| (1.5) | (15) | | | (20.4) | | (33.3) | |
| 26.0 | 60 | | | 4.2 | 1/2 | 7.5 | 3/4 |
| (1.8) | (18) | | | (15.9) | | (28.4) | |
| 30.3 | 70 | | | | | 6.1 | 3/4 |
| (2.1) | (21) | | | | | (23.1) | |

NOTE: Progressively longer life may be expected as operating pressures and speeds are reduced. Factory Application Engineering assistance suggested for operation in light shaded area and recommended for heavy shaded area. Capacitor type motor recommended. Table shows approximate Head-Flow for new pump in U.S. gallons (and liters) per minute.

JABSCO PRODUCTS 

Marine and Recreation Components Division
International Telephone and Telegraph Corporation
1485 Dale Way, Costa Mesa, California 92626

Telephone: (714) 545-6251

For technical advice or service please take your pump into your local pump service center.
To order pump or parts or for pricing please go to the following links :

[Jabsco Pumps Home >>](#)

[Jabsco Pumps stock list >>](#)