

Models **16400-SERIES** **16410-SERIES**

DRUM PUMPS

FEATURES

Tube: Polypropylene or Stainless Steel
Impeller: Centrifugal Type, Tetzl
Shaft: Carpenter 20 Cb-3 or 316 58
Seal: Sealless with Viton* Vapor Barrier
Port: 1 inch Dia. Slip-on Hose Discharge
Weight: 2.8lbs. (1,3kgs.) average for 16400-series
 7.5lbs. (3,4kgs.) average for 16410-series

VARIATIONS AVAILABLE

MODEL NO.	DESCRIPTION
16400-0270	2' (68cm) long, polypropylene
-0350	35-1/2" (90cm) long, polypropylene
-0470	4' (9cm) long, polypropylene
16410-0270	27" (68cm) long, stainless steel
-0350	35-1/2" (90cm) long, stainless steel
-0470	47" (119cm) long, stainless steel

Models 16400-SERIES 16410-SERIES

APPLICATIONS

Designed for emptying containers, carboys, drums and vats. Easily handles the most corrosive of liquids. **WARNING: WHEN PRODUCT IS USED IN AREAS WHERE FLAMMABLE LIQUIDS OR VAPORS ARE PRESENT, APPROPRIATE EXPLOSION PROOF MOTOR OR AIR MOTOR MUST BE USED. If WARNING IS IGNORED, EXPLOSION AND DEATH MAY OCCUR.**

Refer to Chemical Resistance Table in the JABSCO Industrial Catalog (form 43001-0075) for assistance in selecting the most suitable pump material. The catalog is available upon request from the ITT JABSCO factory.

OPERATING INSTRUCTIONS

- General** - When operating the JABSCO drum pump protective clothing, gloves, and safety glasses should be worn. All standard safety practices should be followed.
- Installation** - Pump may be mounted through bung hole in drums, on side of vats and tanks, and through top of carboys. Barrel Adaptors are available to hold pump in stationary or rigid position. When inserting drum pump into barrel, vat or drum slowly lower pump into container to avoid spills. Correct pump length should be selected for container with which pump is to be used.
- Drive** - An electric motor (16420-series) and an air motor (16440-series) are available to drive the drum pump. Both readily fit on the drive end of the pump. Refer to the motor data sheets for details (forms 43000-0468 and 43000-0469).
- Running Dry** - Unit has been designed for limited run dry capability. Do not run dry for more than 30 minutes. Lack of liquid will eventually damage bearings and other pump parts.
- Discharge Line** - A 1" dia. barbed hose fitting has been provided on the drum pump. A tightly secured hose clamp must be used to hold the discharge hose on the discharge fitting. It is recommended that smooth bore hose of a material compatible with the fluid pumped be used as a discharge hose. Adequately secure discharge end of hose to prevent hose from whipping when pump is started.
- NOTICE** - When corrosive fluids are handled, pump life will be prolonged if pump is flushed with water after each use or after each work day. For further information, consult JABSCO Chemical Resistance Table (available upon request from ITT JABSCO) or factory.
- Pressures** - The drum pump is designed to operate in containers open to the atmosphere, therefore maximum inlet pressure is atmospheric pressure (0 psig, 0 bar). For higher inlet pressure applications consult factory.
- Temperatures** - Polypropylene pumps are suitable for service at 32° - 130°F (0 - 55°C). stainless steel pumps 32° - 200°F (0 - 93°C).
- Storage** - When not in use store drum pump on wall bracket with impeller end in down position to allow fluid drainage.

10. **Static Charge** - Certain fluids when pumped create a static charge. When handling these fluids a ground wire must be used to discharge any static charge. WARNING: POTENTIAL STATIC ELECTRIC CHARGE. EXTREME CARE SHOULD BE TAKEN WHEN USING AIR MOTOR IN AN AREA WHERE FLAMMABLE VAPORS ARE PRESENT. A GROUND WIRE MUST BE USED TO DISCHARGE ANY ACCUMULATED STATIC CHARGE. IF WARNING IS IGNORED EXPLOSION AND DEATH MAY OCCUR. One end of ground wire should be damped to the pump bearing housing and the other end clamped to the metal drum or a grounded object.
11. Row Regulation - In applications such as filling small containers where low flow rates are required to avoid splashing of liquid an adjustable nozzle is available.
12. Dirt and Abrasive Particles - It is strongly recommended that when pumping any materials containing dirt or abrasive particles a strainer be used. Strainers are available as an option.
13. Performance Limits - A maximum specific gravity of 1.8 or viscosity of 3500 ssu (750 cp) is the recommended limit for normal use. Contact factory for further information.
14. Spare Parts - Use JABSCO service parts for replacement and repair.

SERVICE INSTRUCTIONS

CAUTION: CHEMICAL HAZARD. PUMPS WHICH HAVE HANDLED CORROSIVE, CAUSTIC OR TOXIC FLUIDS SHOULD BE DRAINED AND COMPLETELY FLUSHED PRIOR TO SERVICING. FAILURE TO DO SO MAY CAUSE INJURY.

Disassembly

1. Unscrew and remove impeller housing.
2. Insert a screwdriver through the drive coupling into the slot provided on the bearing shaft. While preventing the bearing shaft from rotating with the screwdriver, use the four pegs on the bottom of the impeller housing as a wrench and unscrew and remove the impeller sub-assembly. This is a right-hand thread connection as are all connections on the JABSCO drum pump.
3. Unscrew and remove the conversion chamber.
4. Unscrew and remove the outer tube.
5. Slide the tube support off of the inner tube.
6. Remove the shaft extension by inserting a screwdriver through the drive coupling into the slot on the bearing shaft and rotating the bearing shaft counterclockwise while holding shaft extension.
7. Unscrew and remove the inner tube from the discharge port housing.
8. Gently pull the insert tube from the inner tube.
9. Unscrew and remove the discharge port housing.
10. Remove the retaining ring from the mounting ring by inserting screwdriver in one of the four slots provided and pry outward.
11. Slip mounting ring from bearing housing.
12. Remove motor coupling from bearing shaft by inserting screwdriver into slot of bearing shaft and rotating coupling counterclockwise.
13. Remove bearing retaining ring from bearing housing.
14. Pull bearing shaft and bearings from bearing housing.
15. Press bearings off shaft.



Assembly

1. Press bearings on bearing shaft.
2. Insert bearing shaft and bearings into bearing housing.
3. Install bearing retaining into bearing housing.
4. Screw molar coupling onto bearing shaft while holding shaft from rotating with screwdriver in the slot provided. This is a right-hand thread connection as are all connections on the JABSCO drum pump.
5. Slip mounting ring on bearing housing.
6. Insert retaining ring into mounting ring.
7. Screw discharge port housing to bearing housing taking care that lip seal is positioned correctly on bearing shaft, and not damaged during assembly.
8. Install insert tube into inner tube.
9. Screw inner tube to discharge port housing.
10. Slide shaft extension up center of insert tube and screw into bearing shaft by turning bearing shaft with screwdriver while holding shaft extension.
11. Slide tube support about half way up the inner tube.
12. Screw outer tube into discharge port housing.
13. Screw the conversion chamber to the outer tube.
14. Insert impeller sub-assembly through conversion chamber into shaft extension and tighten using the four pegs on the impeller housing as a wrench while holding shaft from rotating with a screwdriver in the slot provided.
15. Screw impeller housing to conversion chamber.
Do not operate pump without impeller housing installed.



16400-SERIES & 16410-SERIES EXPLODED VIEW

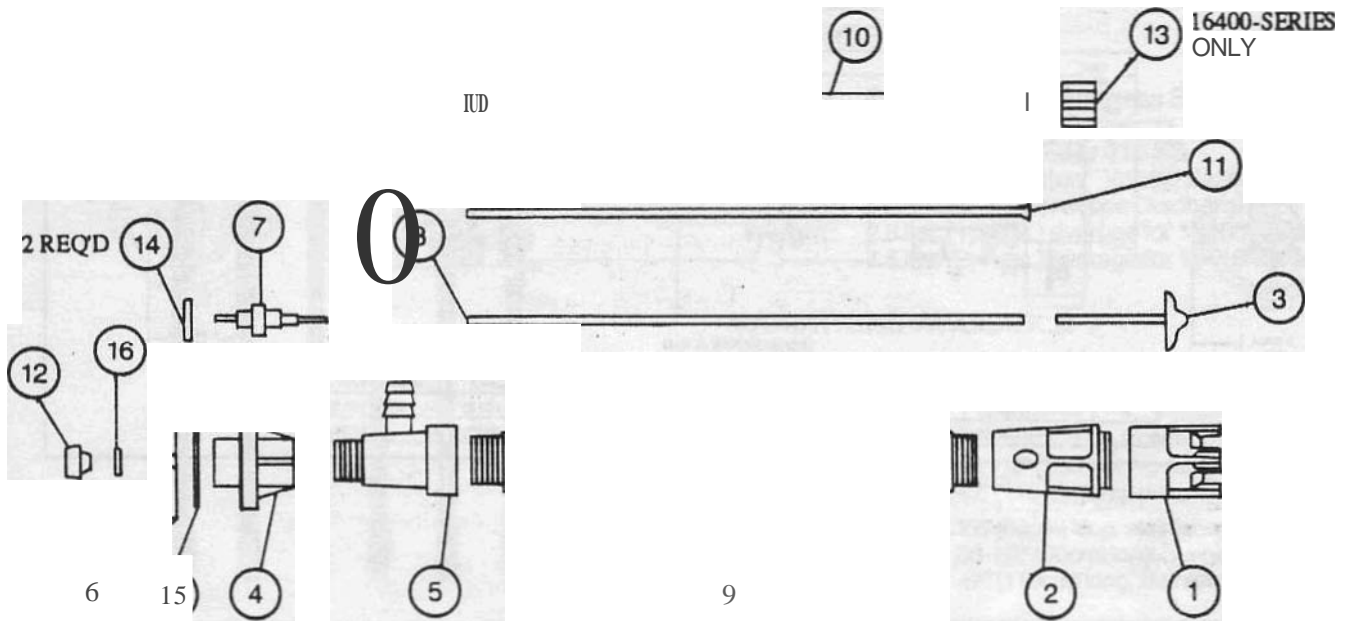

PARTS LIST

KEY	DESCRIPTION	QTY. REQD	MODEL 16400-0270	MODEL 16400-0350	MODEL 16400-0470	MODEL 16410-0270	MODEL 16410-0350	MODEL 16410-0470
1	Impeller Housing	1	16406-0000	16406-0000	16406-0000	16406-0001	16406-0001	16406-0001
2	Conversion Chamber	1	43990-0007	43990-0007	43990-0007	43990-0008	43990-0008	43990-0008
3	Impeller Sub-Assembly	1	43990-0003	43990-0003	43990-0003	43990-0004	43990-0004	43990-0004
4	Bearing Housing	1	16403-0010	16403-0010	16403-0010	16403-0010	16403-0010	16403-0010
5	Discharge Pump Housing	1	16503-0000	16503-0000	16503-0000	16503-0001	16503-0001	16503-0001
6	Mounting Ring	1	16409-0000	16409-0000	16409-0000	16409-0000	16409-0000	16409-0000
7	Bearing Shaft	1	16468-0000	16468-0000	16468-0000	16468-0002	16468-0002	16468-0002
8	Shaft Extension	1	16418-0000	16418-0001	16418-0002	16418-0006	16418-0007	16418-0008
9	Outer Tube	1	16465-0000	16465-0001	16465-0002	16461-0000	16461-0001	16461-0002
10	Inner Tube	1	16464-0000	16464-0001	16464-0002	16462-0000	16462-0001	16462-0002
11	Insert Tube	1	16463-0000	16463-0001	16463-0002	16463-0000	16463-0001	16463-0002
12	Dove Coupling	1	16500-0000	16500-0000	16500-0000	16500-0000	16500-0000	16500-0000
13	Tube Support	1	16466-0000	16466-0000	16466-0000	-	-	-
14	Bearing	2	18753-0182	18753-0182	18753-0182	18753-0182	18753-0182	18753-0182
15	Retaining Ring	1	91701-4433	91701-4433	91701-4433	91701-4433	91701-4433	91701-4433
16	Retaining Ring	1	91701-4434	91701-4434	91701-4434	91701-4434	91701-4434	91701-4434

DIMENSION DRAWING INCHES (MILUMETRES)

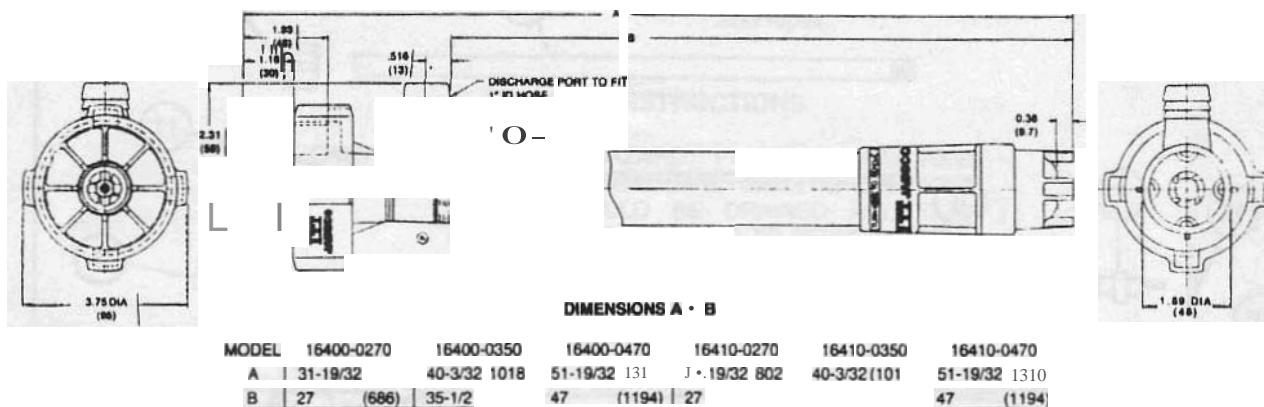

PERFORMANCE TABLES

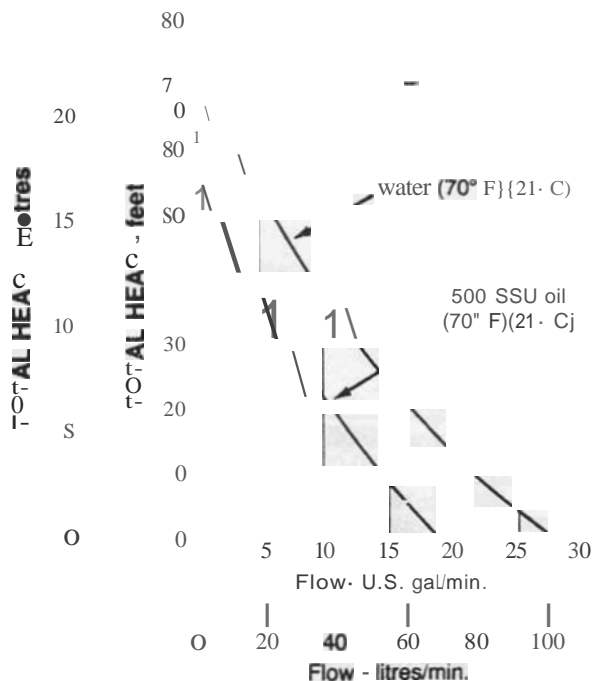

Pump tube with electric motor.

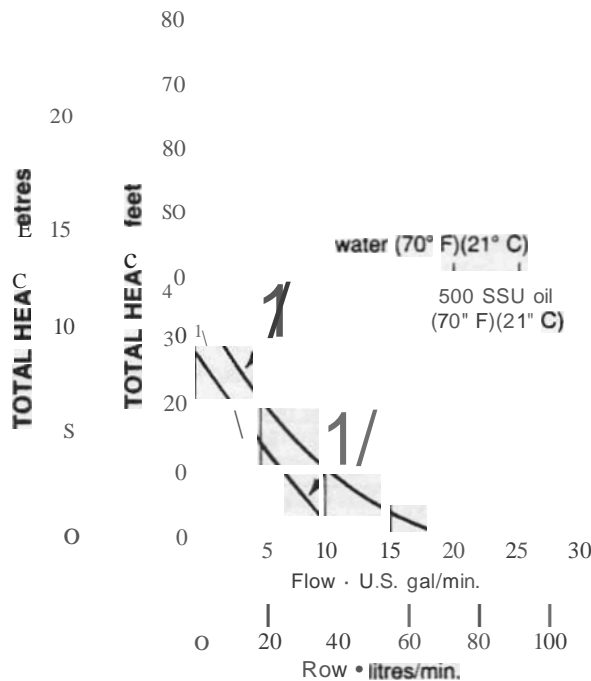

Pump tube with air motor operating at 80 psi (5.5 bar) Inlet air pressure to motor.

THE PRODUCTS DESCRIBED HEREIN ARE SUBJECT TO THE JABSCO ONE YEAR LIMITED WARRANTY, WHICH IS AVAILABLE FOR YOUR INSPECTION UPON REQUEST.

ITT JABSCO

A Unit of In Corporation

4800 Dale Way, P.O. Box 2158

For technical advice or service please take your pump into your local pump service center.
To order pump or parts or for pricing please go to the following links :

[Jabsco Pumps Home >>](#)

[Jabsco Pumps stock list >>](#)