

# MODEL 15210 Series 15230 Series 15250 Series 15270 Series

## JABSCO® PUMPS

Pureflo® Sanitary

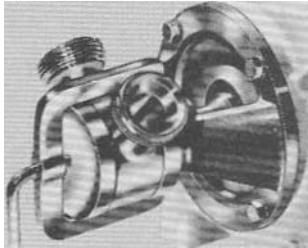

### DESIGN FEATURES

- Body: Type 316 **Stainless Steel**
- Impeller: **Jabsc** Neoprene Compound
- Seal: Sanitary Mechanical-Carbon Face
- Ports: 15210-0665 } **1½" Acme** Sanitary  
 15230-0665 } Threads, Ground Seat
- 15250-0665 } **2" Acme** **Sanitary**  
 15270-0665 } Threads, Ground Selt
- Motor: Model **15210-0665** Sinituy **¾ HP**  
 T.E.N.V., 1150 RPM,  
**3-Phase**, 220/440V B.II  
**Bearing, Shaft-Type**  
 303 **Stainless StHI**
- Model 15210-2665 Open Drip Proof **¾ HP**  
 115/230V Single Phlse  
 1750 RPM Shift-Type  
 303 **Stainless Steel**
- Model 15230-0665 Sanitary **2 HP**, 1750  
**RPM**, **3 - Ph1Se**,  
 220/440V., Bill  
 Bearing, Shift-Type  
**303 Stainless Steel**
- Model 15250-0665 **Sanitary** - **3 HP**, 1160  
 RPM, **3.Ph1S1**,  
 220/440V., Bill **Bear-**  
**ing, Shift-Type** 303  
**Stainless Steel**
- Model 15270-0655 **Sanitary** - **3 HP**, 1160  
 RPM, **3-Phase** 220/440  
 V., Ball Beering, Shaft-  
 Type 303 **Stinless**  
**Steel**

Pureflo® Motor Pump Units

### VARIATIONS AVAILABLE

Old Model Number Standard	Old # Suffi	10 GPM Single	15 GPM	25 GPM	38 GPM	74 GPM
Standard Neoprene Impeller & Clean In Place Ports	II	S10-1M5	S10-MS	S25-M5	S38-M5	1 1" IIS
High Pressure Neoprene Impeller & Acme Ports	II	15210-2665	15210-0665	15230-0665	15250-0665	15270-0655
High Pressure Neoprene Impeller & CIP Ports	II	15210-2765	15210-0765	15230-0765	15250-0765	15270-0755
High Pressure Neoprene Impeller & Acme Ports	II	15210-2675	15210-0675	15230-0675	15250-0675	
Nitrile Impeller & Acme Port	●	15210-2775	15210-0775	15230-0775	15250-0775	
Nitrile Impell. & CIP Ports	●1N	15210-2663	15210-0663	15230-0663		
	●1N	15210-2763	15210-0763	15230-0763		

NOTE: Sanitary **Nitrile Impellers** are available in the models shown above to handle food products having **high** oil content.

Weight: Model 15210-0665 54 lbs. (approx.)  
 Model 15210-2665 95 lbs. (approx.)  
 Model 15230-0665 54 lbs. (approx.)  
 Model 15250-0665 110 lbs. (approx.)  
 Model 15270-0665 123 lbs. (approx.)

### APPLICATIONS AND OPERATING INSTRUCTIONS

Some of the many diverse products handled by Jabsc Pureflo pumps include: DAIRY PROCESSING: Butternilk, Condensed Milk, Cream, Milk, Eggs, Whey and other assorted dairy products. FOOD PROCESSING: Sugar Liquors, Brines, Calsup, Chocolate, Ghlze, Gelatin, Halley, Jams, Jellies, Mayonnaise, Molasses, Mustard, Pickle Relish, Vinegar, Water, Yeast Slurries. BEVERAGE PROCESSING: Alcohols, Beers, Brewery Slop, Cider, Distillery Wort, Extracts, Flavors, Juices, Mash, Soft Drinks, Wines. MISCELLANEOUS: Chemicals, Cosmetics, Pharmaceuticals. Jabsc Pureflo Malar rump Units will pump fluids to the viscosity range of 500 SSU. Fluids with a higher viscosity

range should be handled with a Pedestal Mount Pureno Pump operating at reduced speeds.

1. INSTALLATION - Pump may be mounted in any position. Pump head rotates 360° to permit desired port location. Intake and discharge ports are determined by the direction of shaft rotation. looking at end cover with clockwise rotation, inlet port is on horizontal right, with left port vertical.
2. SELF-PRIMING - Pump will produce 15 feet of vertical suction lift when dry and 22 feet of lift when wetted. INTAKE LINES MUST BE AIR-TIGHT to prevent product foaming and assure self-priming.

3. RUNNING DRY - The impeller is lubricated by the product being pumped. DO NOT RUN DRY for more than 30 seconds. Lack of liquid may damage the impeller.
4. TEMPERATURES - 40°-150°F. Contact factory for impeller recommendation on applications outside this range. Other impeller compounds are available which may be utilized for certain applications at higher or lower temperatures.
5. PRESSURES - Consult performance chart. When operating pressures approach the upper recommended ranges for standard pressure impellers, it is ordinarily desirable to use a high pressure model to increase impeller life.

EXPLODED VIEW

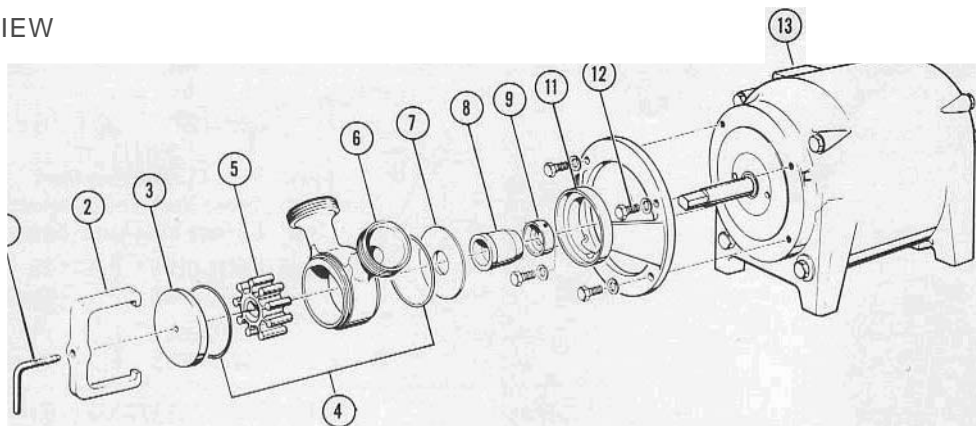

1521 0-Series

KEY	DESCRIPTION	PART NUMBER	S.i.1 No. 10-AJ 140a thru 10-AJ1551		Se.i.1 No. 10-1216 thru IQ-Jt3120 10-41 th., 10-41 9		QTY
			6-72 & Subsequent	IQ-A41 thru 10-A99 3-70 thru 5-72	Se.i.1 No. 10-1216 thru IQ-Jt3120 10-41 th., 10-41 9	Se.i.1 No. 10-11 thru 10-1215	
1	Clamp Screw	10408-0010	10408-0010				1
2	Clamp	12695-0000	12695-0000	<b>12534-0000</b>		98018-0020	1
3	End Cover	10435-0001	10435-0001	9268-0000		8253-0000	1
4*	O Ring (Body)	<b>92000-0290</b>	92000 0290	92000-0720		92000,0650	2
5*	Neoprene Imp (Std.1)	7614-0005	<b>7614-0005</b>	7614-0005		7614,0005	1
	Neoprene Imp (H.P.)	8980-0005	8980-0005	8980-0005		8980-0005	
	Nitrile Imp (Std)	7614-0006	7614-0006	7614-0006		7614-0006	
	Nitrile Imp (H.P.)	8980-0006	8980-0006	8980-0006		8980-0006	
6	Body (Acme)	15014-0061	15014-0061	<b>9265-0000</b>		7564-0000	1
	Body (elPI)	15014-0071	15014-0071	9266-0000		7564-0010	
Not Shown*	O Ring (ICIP Port)	92000-0710	<b>92000-0710</b>	92000-0110		92000-0710	2
7	Wear Plate	10396-0010	10396-0010	9267-0000		7806-0000	1
8*	Seal Assy	7749-0000	7749-0000	<b>7749-0000</b>		7749-0000	1
9	Seal Collar	5301-0000	5307-0000	5301-0000		5307-0000	1
Not Shown*	Allen Wrench	92351-0050	92351-0050	92351-0050		<b>92351-0050</b>	1
11	Adaptor	12694-0000	12694-0000	<b>7565-0000</b>		<b>7565-0000</b>	1
12	Bolt	91094-0230	91094-0070	81106-0040		91106-0040	4
	Washer	91602-0260	91602-0090	81602-0090		91602-0090	4
13	Motor 3 Phase 3/4 HP	93004-1030	93004-1030	93004-0670		93004-0670	1
	Motor Single Phase 3/4 HP	83004-1020	93004-1020	83004-0660		93004-0660	
	Service Kit Neoprene (Std.1)	<b>90072-0005</b>	90072-0005	<b>90072-0005</b>			
	Neoprene (H.P.)	80073-0005	<b>90073-0005</b>	90073-0005			
	Nitrile (Std.1)	<b>90072-0003</b>	<b>90072-0003</b>	<b>90072-0003</b>			

\*Parts supplied in Service Kit

## SERVICE INSTRUCTIONS

## All Model Pumps

## ASSEMBLY AND DISASSEMBLY OF PUMP HEAD

Before using pump it should be disassembled and cleaned to remove any dust and dirt resulting from storage or shipping. Wash parts in standard cleaning solutions approved for handling stainless steel. Thoroughly rinse before reassembly. **DO NOT USE IODINE BASED SANITIZERS** as the iodine attacks the elastomer materials used in the impeller.

All parts have been expertly machined and polished. **HANDLE WITH CARE. DO NOT DROP OR MISHANDLE.**

## DISASSEMBLY

1. Remove end cover clamp, end cover and "O" ring.
2. Grasp pump ports and slide pump body and impeller from shaft.
3. Remove "O" ring and then push the impeller from the pump body.
4. Remove wearplate from pump.
5. Slide seal assembly off the shaft. Do not damage the carbon seal face in handling. Do not loosen or remove seal collar, except as noted below.

## ASSEMBLY

1. Slide seal assembly onto shaft (carbon face toward pump head).
2. Replace wearplate. **BE SURE THAT FLAT SIDE IS TOWARD PUMP HEAD AND THE SIDE WITH THE RAISED BOSS IS TOWARD CARBON FACE OF SEAL ASSEMBLY.**
3. Lubricate bore of pump body with Orange **Solid Grease** or suitable substitute and then replace **impeller** into pump body by twisting and pushing at same time.
4. Replace two "O" rings on either side of body and install assembly on shaft. (Impeller blades bent under cam should point in opposite direction to operational rotation.)
5. Position end cover and then replace end cover clamp. **CLAMP SHOULD BE HAND TIGHTENED.** Do not use wrench or hammer.

*NOTE:* The seal collar is set at the factory to provide *proper* seal compression and should not require further adjustment.

*If adjustment is required:*

With pump head disassembled, loosen two set screws on seal collar. Replace seal assembly on shaft and then install wearplate in *Reverse Position* with flat side toward seal. While holding wearplate in position against adapter, push seal assembly and seal collar against wearplate and tighten the two set screws in seal collar. Remove wearplate and replace to correct *Position* with raised boss against carbon face of seal before assembling *pump*. **DO NOT DISASSEMBLE PUMP WITH WEARPLATE IN REVERSE POSITION.**

## HEAD CAPACITY TABLES

## STANDARD PRESSURE MODELS

15210-0665, -0765 -2665, -2765.				15230,0665, -0765				<b>15250-0665, -0765</b>				15270-0665, -0755			
TOTAL HEAD		1750 RPM		TOTAL HEAD		1750 RPM		TOTAL HEAD		1160 RPM		TOTAL HEAD		1160 RPM	
lbs. per Sq. In.	Ft. of Water	GPM	HIP	lbs. per Sq. In.	Ft. of Water	GPM	HIP	lbs. per Sq. In.	ft. of Water	GPM	HIP	lbs. per Sq. In.	ft. of Water	GPM	HIP
4.3	10	11.3	¾	4.3	1G	25.5	2	4.3	1G	35.2	3	8.7	20	74	3
8.7	20	10.2	¾	8.7	2G	24.6	2	8.7	20	33.8	3	17.3	40	62	3
13.0	30	9.0	¾	17.3	40	23.0	2	17.3	40	29.4	3	21.6	50	54	3
21.6	5G	5.2	¾	26.0	60	21.0	2	26.0	60	23.2	3				
				34.6	80	18.0	2								

## HIGH PRESSURE MODELS

15210-0675, -0115 -2675, -2775				15230-0675, -0775				15250-0675, -0775			
TOTAL HEAD		1750 RPM		TOTAL HEAD		1750 RPM		TOTAL HEAD		1160 RPM	
lbs. per Sq. In.	Ft. of Water	GPM	HIP	lbs. per Sq. In.	ft. of Water	GPM	HIP	lbs. per Sq. In.	ft. of Water	GPM	HIP
8.7	2G	10.4	¾	17.3	40	22.8	2	8.7	20	37.4	3
17.3	4G	8.7	¾	26.0	6G	21.9	2	21.6	50	36.8	3
26.0	6G	6.2	¾	34.6	8G	20.8	2	34.6	80	35.0	3
34.6	80	4.6	¾	51.5	12G	17.1	2	47.6	11G	32.7	3
				60.5	14G	14.2	2	60.5	14G	28.5	3

15230-Series

KEY	DESCRIPTION	Serial No.		QTY
		25-A41 and Subsequent	25-11 thru 25-32370 25-41 thru 25-445	
		PART NUMBER	PART NUMBER	
1	Clamp Screw	9551-0010		1
2	Clamp	12698-0000	12533-0000	1
3	End Cover	10515-0001	8825-0000	1
4	O Ring 180dyl	92000-0310	92000-0690	2
5	Neoprene Imp. (Std.)	8981-0005	8981-0005	1
	Neoprene Imp. (HT)	8840-0005	8840-0005	
	Nitrile Imp (Std)	8840-0006	8840-0006	
6	Body (Acme)	15034-0061	8608.Q000	1
	Body (CIP)	15034-0071	8808-0000	
HOI Shown	O Ring (CIP Port)	92000-0710	92000-0110	2
7	Wear PIT	10046-0010	8806-0000	1
	Seal Assy	8728-0000	8728-0000	1
8	Seal Collar	8727-0000	8727-0000	1
No. Shown:	Allen Wrench	92351-0050	92351-0050	1
11	Adaptor	14034-0000		
12	Bolt	91094-0070	91106-0040	0
	Washer	91602-0090	91602-0090	●
13	Motor (2 HP)	93004-1010	93004-0680	1
	Service Kit			
	Neoprene (Std.)	90089-0005	90089-0005	
	Neoprene (HP)	90090-0005	90090-0005	
	Nitrile (Std.)	90090-0006	90090-0006	

\* Parts supplied in Service Kit

15250-series

KEY	DESCRIPTION	Serial No.			QTY
		50-A41 and Subsequent	50-251 thru 50-32610 50-41 thru 50445	50-11 thru 50-250	
		PART NUMBER	PART NUMBER	PART NUMBER	
1	Clamp Screw	10697-0010			1
2	Clamp	129960000	12058-0000	98018-0080	1
3	End Cover	10299-0001	12056-0000	120560000	1
4	O Ring (Body)	92000-0040	92000-0740	92000-0700	2
5	Neoprene Imp (S,d,l)	14346-0005	14346-0005	14346-0005	1
	Neoprene Imp. (H.P.)	8983-0005	8983-0005	8983-0005	
6	Body (Acme)	15054-0061	8994-0000	8994-0000	1
	Body (CIP)	15054-0071	12024-0000	12024-0000	
NOI Shown	O Ring (CIP Port)	92000-0130	92000-0730	92000-0730	2
7	Wear PIT	10276-0010	8896-0000	8896-0000	1
	Seal Assy	9023-0000	9023-0000	9023-0000	1
8	Seal Collar	1866-0000	1866-0000	7866-0000	1
No. Shown:	Allen Wrench	92351-0050	92351-0050	92351-0050	1
11	Adaptor	14094-0000	8894-0000	8894-0000	1
12	Bol,	91094-0070	91106-0040	91106-0040	●
	Washer	91602,0090	91602-0090	91602-0090	●
13	Motor (3 Hpi)	93004-1680	93004-0690	93004-0690	1
	Service Kit				
	Neoprene (Std.)	90093-0005	90093-0005		
	Neoprene (Hp,l)	90094-0005	90094-0005		

\* Parts supplied in Service Kit

15270-Series

KEY	DESCRIPTION	PART NUMBER	Serial No.	Serial No.	Serial No.	QTY
			thru 100-A99 3-10 thru 1-10	1110-3198 thru 100-33180 any 100-41 thru 483	100-1 thru 100-3197	
1	Clamp Screw	10354-0010	10354-0010			1
2	Clamp	12927-0000	12927-0000	12197-0000		1
3	End Cover	10345-0001	10345-0001	12531-0000	8965-0000	1
0"	II Ring (Body)	92000-0030	92000-0030	92000-0630	92000-0630	2
III	Neoprene Imp. (Std.)	8963-0005	8984-0005	8984-0005	8984-0005	1
●	Body (Acme)	15074-0061	150140061	7994-0000	7994-0000	1
	Body (CIP)	15074-0071	15014-0011	12014-0000	12014-0000	1
Not Shown	a Ring (CIP Port)	92000-0730	92000-0730	92000-0730	92000-0730	2
7	Wear Plate	10346-0010	10346-0010	7096-11000	10960000	1
II	Seal Assy	14052-0000	14052-0000	14052-0000	14052-0000	1
7	Seal Collar	8248-0000	8248-0000	8241-0000	8241-0000	1
Not Shown*	Allen Wrench	92351-0050	92351-0050	92351-0050	92351-0050	1
11	Adaptor	14104-0000	14104-0000	8964-0000	8964-0000	1
12	gasket	91094-0070	91094-0070	91106-0040	91106-0040	●
	Washer	91602-0090	91602-0090	91602-0090	91602-0090	●
13	Motor (3 HP)	93004 1690	93004 1080	93004-0690	93004-0690	1
	Service Kit Neoprene (Std.)	90080-0035	90080-0025	90080-0025	90080-0025	

Parts supplied in Service Kit

NOTE: Product viscosity to 500 S.S.U. may be handled by Pureflo motor pumps with 1750 RPM motors.  
Product viscosity to 6000 S.S.U. may be handled by Pureno motor pumps with 1160 RPM motors.

EXPLANATION OF SERIAL NUMBERS:

- Effective March 30, 1970, the Serial Number consists of Month and Year of Manufacture, e.g. 5-70 - May, 1970.
- Prior to March 30, 1970:

The first part of the serial number denotes the capacity of the pump. For example, serial number 100-3021 was used on a 100 GPM pump. The first number in the second series of digits denotes the year the pump was manufactured. For example, serial number 100-3021 reveals the pump was produced in 1963. The use of this digit is VERY IMPORTANT. A pump bearing the serial number 100-401 is a "later" number than serial number 100-3021. Pumps with serial numbers containing the letter "A" are of most recent design except as noted in 1 above.

JABSCO PRODUCTS 

A Unit of International Telephone and Telegraph Corporation, 1485 Dale Way, Costa Mesa, California 92626  
Telephone; (714) 545-8251



---

For technical advice or service please take your pump into your local pump service center.  
To order pump or parts or for pricing please go to the following links :

[Jabsco Pumps Home >>](#)

[Jabsco Pumps stock list >>](#)