

CASING - Casing is close grain iron of 30,000 psi minimum tensile strength. Back pull-out design eliminates the need to disturb piping should the pump ever require service - the casing stays in the line.

ENCLOSED BRONZE IMPELLER - Enclosed Bronze Impeller is of the latest hydraulic design for maximum efficiency. It is balanced for vibration-free operation. It is precision fit to shaft with key drive and cap screw lock.

MECHANICAL SHAFT SEAL - Standard self-adjusting shaft seal for temperatures up to 225°F (107°C) and pressures to 150 psi (1034kpa). Ceramic seat and carbon seal face for long trouble-free service. Special seals are available for higher temperatures and fluids other than water.

JM Type motors have NEMA standard mounting flange, extended steel shaft and dual bearings. These motors offer the advantage of quiet operation, controlled shaft deflection for longer seal life, and bearings sized to provide good service life. All motors are supplied by manufactures with national field service facilities.

Flapper and check valves on the suction pipe are not required, but are recommended.

BRONZE SHAFT SLEEVE - Gasketed and keyed hook-type sleeve protects shaft from wear and corrosion in seal area.

FACTORY TESTED - After careful assembly and inspection, EVERY pump is factory tested and will meet Hydraulic Institute standards.

MOTOR INFORMATION

60 Hz - 3500 RPM - ODP

Three Phase: 5, 7-1/2 & 10 Hp. - 230/460 Volt
Voltages may differ from some suppliers. Consult factory.

Overload Protection: All motors must be installed with a magnetic starter which provides full 3-leg protection. Failure to use correct starter and overloads will void motor warranty.

MAXIMUM OPERATING CONDITIONS

TEMPERATURE (For Standard Buna-N Seal)	225°F (107°C)
INLET PRESSURE	100 PSI (689kPa)
CASING WORKING PRESSURE	200 PSI (1379kPa)

MATERIALS OF CONSTRUCTION

PART	ALL IRON	BRONZE FITTED
Adapter	Cast Iron	Cast Iron
Casing	Cast Iron	Cast Iron
Casing Wear Ring	Steel	Bronze
Impeller	Cast Iron	Bronze
Shaft	#316 Stainless	#316 Stainless
Shaft Seal	Carbon-Ceramic SS - Buna-N	Carbon-Ceramic SS - Buna-N



WARNING:

CANCER AND REPRODUCTIVE HARM -
WWW.P65WARNINGS.CA.GOV

Series: WG6-2

3500 RPM - 60 Hz.
CAPACITIES TO 280 GPM (17.7 LPS)
HEADS TO 178 FEET (54.3m)

www.cranepumps.com - Click here for Pricing/Ordering for Pumps and Parts



Close Coupled Self Priming Pumps

PumpAgents.com
Wholesale Pump Agents

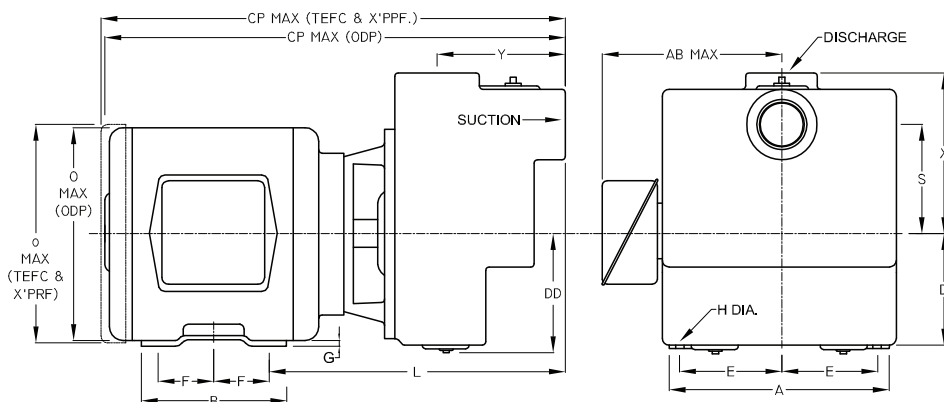
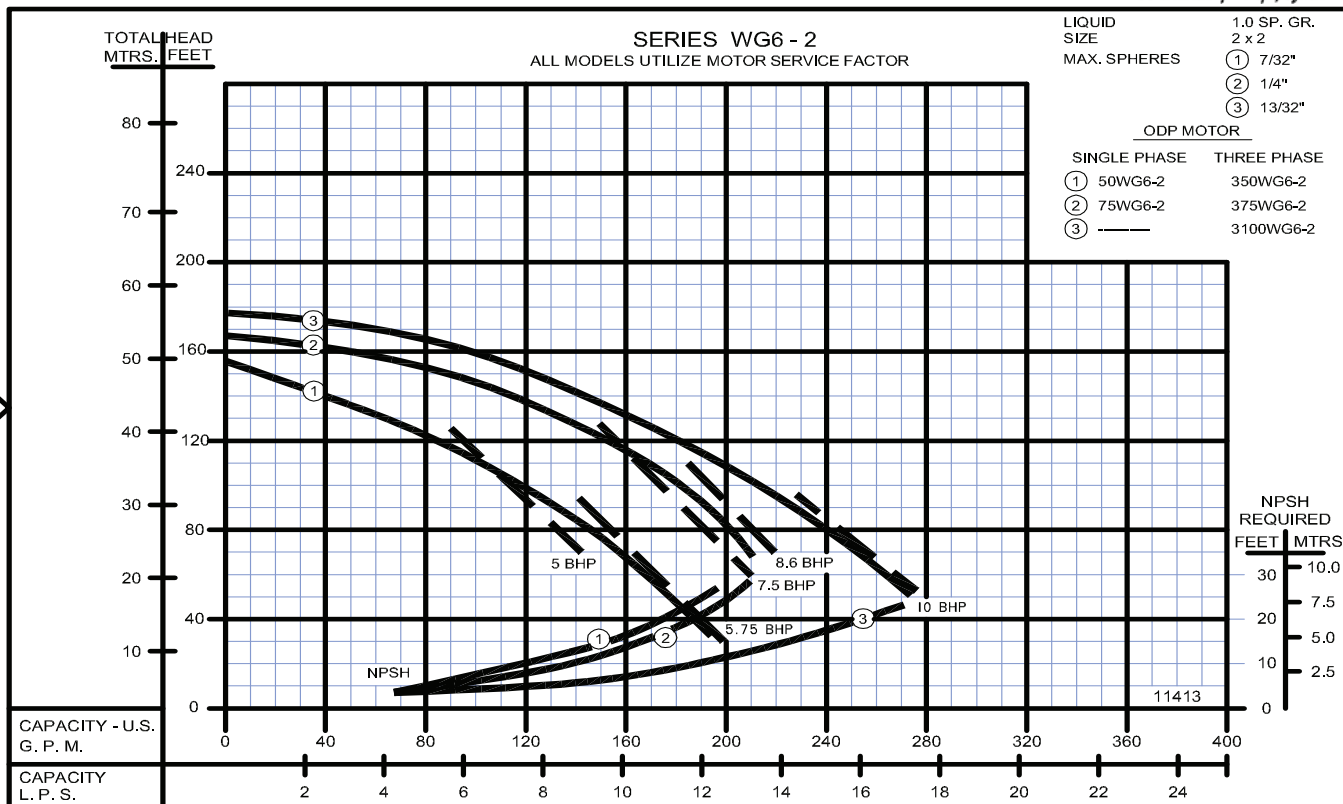

MODEL 3 PHASE	HP	Motor Frame Size	Disc. NPT	Suct. NPT	DIMENSIONS IN INCHES														
					A	AB	B	CP	D	DD	E	F	G	H	L	O	S	X	Y
350WG6-2	5	182JM	2	2	8 ³ / ₄	9 ¹¹ / ₁₆	5 ³ / ₄	21 ¹¹ / ₁₆	4 ¹ / ₂	6 ¹ / ₂	3 ³ / ₄	2 ¹ / ₄	1/2	1 ³ / ₃₂	14	9 ¹ / ₁₆	6 ⁵ / ₁₆	9	6 ¹ / ₁₆
375WG6-2	7.5	184JM	2	2	8 ³ / ₄	9 ¹¹ / ₁₆	6 ³ / ₄	23 ¹¹ / ₁₆	4 ¹ / ₂	6 ¹ / ₂	3 ³ / ₄	2 ³ / ₄	1/2	1 ³ / ₃₂	14	9 ¹ / ₁₆	6 ⁵ / ₁₆	9	6 ¹ / ₁₆
3100WG6-2	10	213JM	2	2	10 ⁵ / ₈	10 ⁷ / ₈	7 ³ / ₄	24 ³ / ₁₆	5 ¹ / ₄	6 ¹ / ₂	4 ¹ / ₄	2 ³ / ₄	5/8	1 ³ / ₃₂	14 ⁷ / ₈	11	6 ⁵ / ₁₆	9	6 ¹ / ₁₆

MODEL 3 PHASE	HP	Motor Frame Size	Disc. NPT (in)	Suct. NPT (in)	DIMENSIONS IN MILLIMETERS														
					A	AB	B	CP	D	DD	E	F	G	H	L	O	S	X	Y
350WG6-2	5	182JM	2	2	222	246	146	551	114	165	95	57	13	10	356	246	160	229	154
375WG6-2	7.5	184JM	2	2	222	246	171	602	114	165	95	70	13	10	356	246	160	229	154
3100WG6-2	10	213JM	2	2	264	276	197	614	133	165	108	70	16	10	378	279	160	229	154

Dimensions shown above are approximate maximum dimensions for standard pumps equipped with open drip-proof motors

SECTION 6
PAGE 8
DATE 1/06



A Crane Co. Company

PUMPS & SYSTEMS

DO NOT USE FOR CONSTRUCTION PURPOSES.
CERTIFIED DRAWINGS AVAILABLE ON REQUEST

USA: (937) 778-8947 • Canada: (905) 457-6223 • International: (937) 615-3598

Centrifugals - Self-Priming

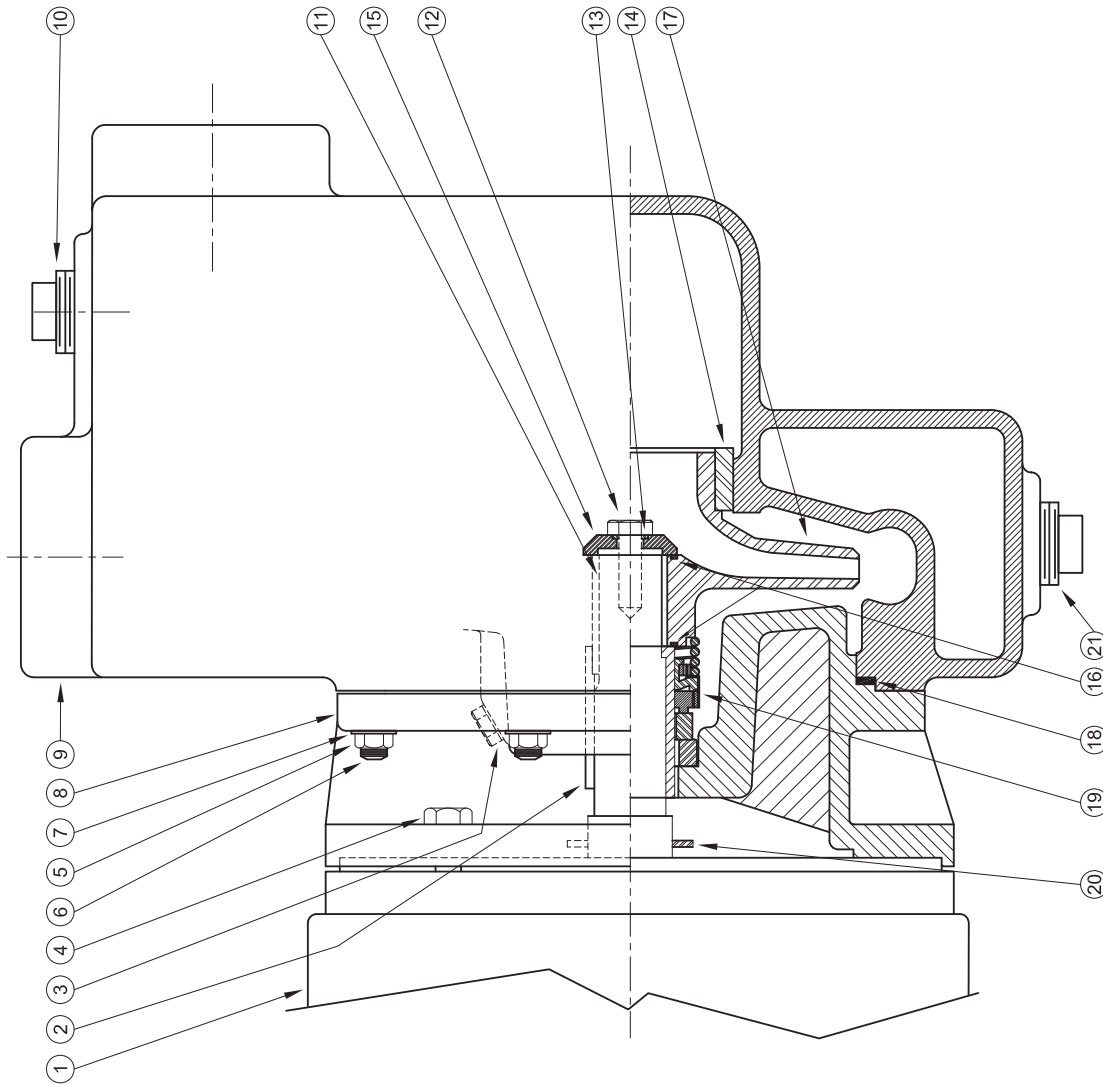

1 - MOTORS		HP	FRAME SIZE
RPM & PHASE	PART NUMBER		
OPEN DRIP PROOF			
3500 RPM Single Phase (ODP)	09902	5	184JM
	21850	7½	213JM
3500 RPM Three Phase (ODP)	09906	5	182JM
	09907	7½	184JM
	09999	10	213JM
TOTALLY ENCLOSED			
3500 RPM Three Phase (TEFC)	09950	5	184JM
	09951	7½	213JM
	20000	10	215JM
EXPLOSION PROOF			
3500 RPM Three Phase (XP)	09954	5	184JM
	09955	7½	213JM
	20001	10	215JM

PumpAgents.com
Wholesale Pump Agents

Centrifugals - Self-Priming

SYMBOL NUMBER	PART NUMBER	QTY	DESCRIPTION
DIFFERING PARTS FOR ALL BRONZE CONSTRUCTION			
8	09912-B	1	Adapter - Bronze, 182-184JM Frames
	09920-B	1	Adapter - Bronze, 213-215JM Frames
* 9	23123-A-1	1	Casing Assy - Bronze w/Bronze Wear Ring - 5 & 7½HP
	23123-A	1	Casing - Bronze
12	03289	1	Cap Screw, 3/8-16 x 1" Lg - Bronze
DIFFERING PARTS FOR ALL IRON CONSTRUCTION			
2	22063-A	1	Shaft Sleeve - SS
3	04236-A	1	Plug, 1/4-18 NPT - SS
* 9	23123-B-1	1	Casing Assy - Iron w/Steel Wear Ring - 5 & 7½HP
10	26149	1	Plug, 1-11½ NPT, Sq Hd - Iron
14	23265-A	1	Washer - Steel (23123-B-1 Casing Assy)
15	22105-A	1	Washer - Steel, Impeller Retaining
** 17	20420-A-6.06	1	Impeller - Iron, 5HP
	09928-A-6.25	1	Impeller - Iron, 7½HP
	09929-A-6.25	1	Impeller - Iron, 10HP

(*) Casing Assy includes Symbol 14.
23270-1, -A-1, -B-1 (5 & 7½HP) are complete casing assemblies consisting of symbols 6, 9, 10, 14 & 21.

23270, -A (10HP) are complete casing assemblies consisting of symbols 6, 9, 10 & 21.

(**) Size suffixes same as standard bronze impellers.

SYMBOL NUMBER	PART NUMBER	QTY	DESCRIPTION
2	22063-C	1	Shaft Sleeve - Bronze
3	04236	1	Plug, 1/4-18 NPT - Bronze
4	01928	4	Cap Screw, 3/8-16 x 1" Lg (09912 Adapter)
5	1-68-6	4	Cap Screw, 1/2-13 x 1¼" Lg (09920 Adapter)
	15-23-6	8	Nut, 3/8-16
6	03075	8	Stud, 3/8-16 x 1¾" Lg
7	01609-A	8	Washer
8	09912	1	Adapter - Iron, 182-184JM Frames
	09920	1	Adapter - Iron, 213-215JM Frames
* 9	23123-1	1	Casing Assy - Iron w/Bronze Wear Ring, 5 & 7½HP
	23123	1	Casing Assy - Iron, 10HP
10	02954	1	Plug 1-11½ NPT, Sq Hd - Bronze
11	23014	1	Key, 3/16 Sq x 1½" Lg
12	01928-A	1	Cap Screw, 3/8-16 x 1" Lg - SS
	22080	1	O-Ring - Buna-N (Std)
	22081	1	O-Ring - Viton
13	22082	1	O-Ring - Teflon
	22093	1	O-Ring - EPDM
14	23265	1	Wear Ring - Bronze (23123-1 Casing Assy)
15	22105-C	1	Washer - Bronze, Impeller Retaining
	22083	2	O-Ring - Buna-N (Std)
	22084	2	O-Ring - Viton
16	22085	2	O-Ring - Teflon
	22094	2	O-Ring - EPDM
17	20420-6.06	1	Impeller - Bronze, 5HP
	09928-6.25	1	Impeller - Bronze, 7½HP
	09929-6.25	1	Impeller - Bronze, 10HP
	22099	1	O-Ring - Buna-N (Std)
	23000	1	O-Ring - Viton
18	23002	1	O-Ring - Teflon
	23001	1	O-Ring - EPDM
19	09917	1	Mechanical Seal - Buna-N (Std)
	09926	1	Mechanical Seal - Viton
	21271	1	Mechanical Seal - EPDM
20	09918	1	Slinger Washer
21	00127	2	Plug, Sq Hd - Iron

WARNING:
CANCER AND REPRODUCTIVE HARM -
WWW.P65WARNINGS.CA.GOV

