

SECTION	2B
PAGE	10
ISSUED	2/03
REPLACES	12/01

**SERIES: G6-1-1/2
thru 4G9-4F**

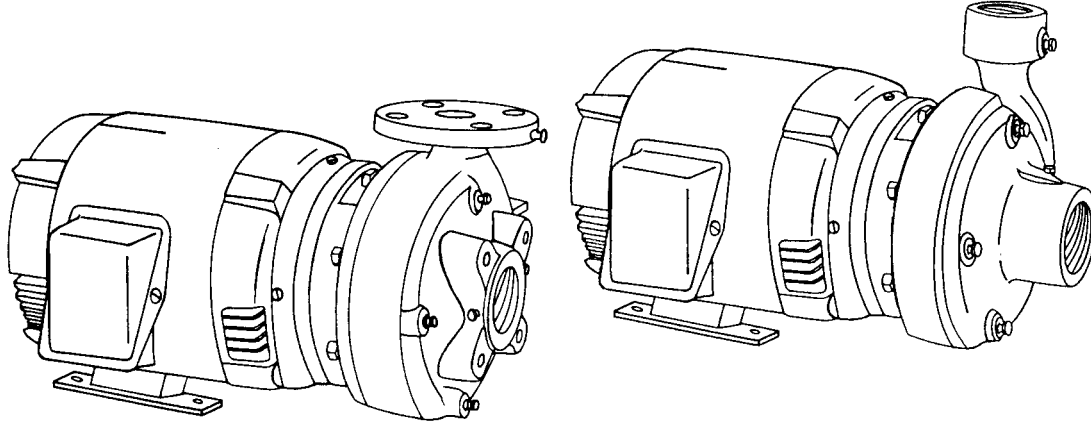

CLOSED COUPLED CENTRIFUGAL PUMPS



3500RPM - 60Hz.
CAPACITIES TO 960GPM (60.6LPS)
HEADS TO 380 FEET (116M)

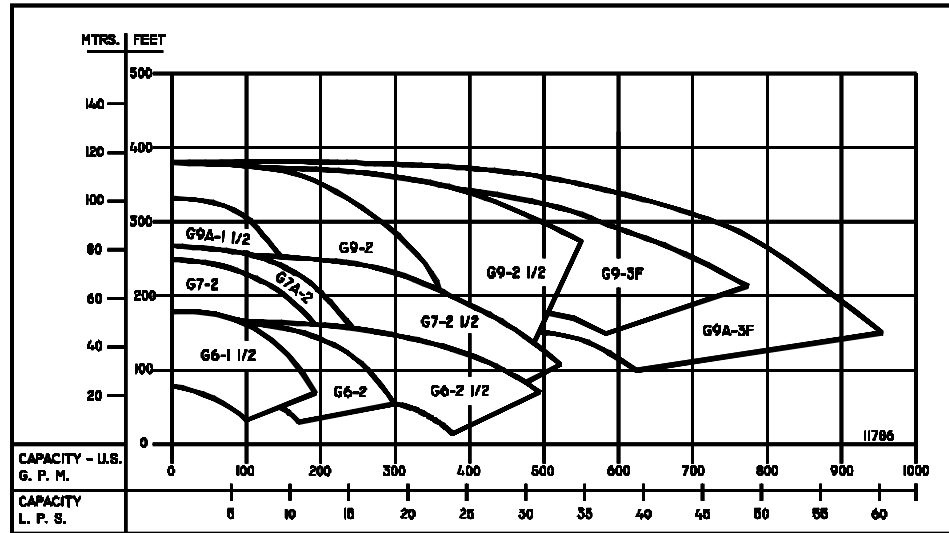

2900RPM - 50Hz.
CAPACITIES TO 630GPM (39.7LPS)
HEADS TO 265 FEET (80.8M)

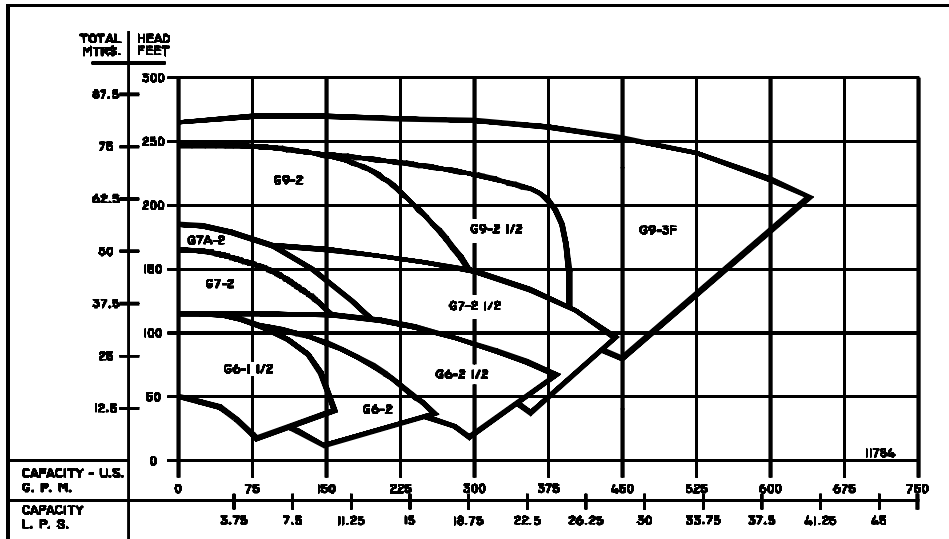

Individual performance curves should be checked for final selection.



A Crane Co. Company

PUMPS & SYSTEMS

PumpAgents.com - buy pumps and parts online



SECTION	2B
PAGE	11
ISSUED	2/03
REPLACES	12/01



PRODUCT FEATURES

1. RADIAL SPLIT CASING DESIGN

Casing is close grain iron of 30,000 p.s.i. minimum tensile strength. Back pull-out design eliminates the need to disturb piping should the pump ever require service - the casing stays in the line. Centerline discharge. Stud mounted casing assures positive alignment and allows rotation of discharge to eight different positions. Openings are provided for test gauges, for venting and for draining the pump.

2. ENCLOSED BRONZE IMPELLER

Enclosed bronze impeller is of latest hydraulic design for maximum efficiency. It is balanced for vibration free operation. Precision fit to shaft and double-locked with key and cap screw.

3. REPLACEABLE CASING WEAR RING

Prevents wear on casing and is easy to replace.

4. MECHANICAL SHAFT SEAL

Mechanical Shaft Seal is self-adjusting for temperatures up to 225°F (107°C) and pressures to 150 psi (1034kpa). Has ceramic seat and carbon seal faces for long trouble-free service. Special seals are available for higher temperatures and fluids other than water. Tapped opening is provided in the seal chamber for flushing seal faces.

5. BRONZE SHAFT SLEEVE

Gasketed and keyed hook-type sleeve protects shaft wear and corrosion in seal area.

6. MOTORS

The standard Type JM motors supplied with these pumps offer the advantages of quiet operation, controlled shaft deflection for longer mechanical seal life and bearings sized to provide good service life. All motors are supplied by manufacturers providing field service facilities.

7. INTERCHANGEABILITY

The complete liquid end of any size pump is interchangeable between motors on close-coupled pumps and the BURKS power frames of comparable size providing inventory flexibility, plus an option for handling emergency service.

8. FACTORY TESTED

After careful assembly and inspection, **EVERY** pump is factory tested and will meet Hydraulic Institute standards.

FOR TEMPERATURES TO 500°F (260°C).

All models, with the exception of the G7-2-1/2 and all G9 series pumps are available in a Jacketed Seal Cavity design for pumping hot oil, hot water and heat transfer fluids in common use in high temperature heating or cooling applications. This feature greatly extends seal life in high temperature applications. To order, add suffix "MJ" to pump catalog number for temperatures below 400°F (204°C) and add suffix "MJK" to pump catalog number for temperatures over 400°F (204°C). Example: G6-1-1/2MJ. See Section on High Temperature Pumps for more information.

MAXIMUM OPERATING CONDITIONS	
Maximum Pumping Temperature*	225°F (107°C)
Maximum Inlet Pressure	100 PSI (690kpa)
Maximum Case Working Pressure	200 PSI (1379kpa)

* FOR STANDARD BUNA-N SEAL

SUCTION & DISCHARGE SIZES		
* SERIES	SUCTION	DISCHARGE
G6-1-1/2	2"	1-1/2"
G6-2 & 2F	2-1/2"	2"
G6-2-1/2 & 2-1/2F	3"	2-1/2"
G7-2 & 2F	2-1/2"	2"
G7A-2 & 2F	2-1/2"	2"
G7-2-1/2 & 2-1/2F	3"	2-1/2"
G9-1-1/2	2"	1-1/2"
G9-2 & 2F	2-1/2"	2"
G9-2-1/2 & 2-1/2F	3"	2-1/2"
G9-3F & G9A-3F	4"	3"
G9-4F	5"	4"

*F Suffix Denotes ANSI 125# Flat Face Flanges

MATERIALS OF CONSTRUCTION			
Part	Bronze Fitted	All Bronze	All Iron
Adapter	Cast Iron	Bronze	Cast Iron
Casing	Cast Iron	Bronze	Cast Iron
Casing wear ring	Bronze	Bronze	Steel
Shaft	Steel	Steel	Steel
Shaft sleeve	Bronze	Bronze	#316 S. Steel
Impeller	Bronze	Bronze	Cast Iron
Shaft seal	Carbon-Ceramic S. Steel-Buna-N	Carbon-Ceramic S. Steel-Buna-N	Carbon-Ceramic S. Steel-Buna-N



SECTION	2B
PAGE	22
ISSUED	2/03
REPLACES	12/01

60Hz PERFORMANCE CURVE



END SUCTION CENTRIFUGAL PUMPS

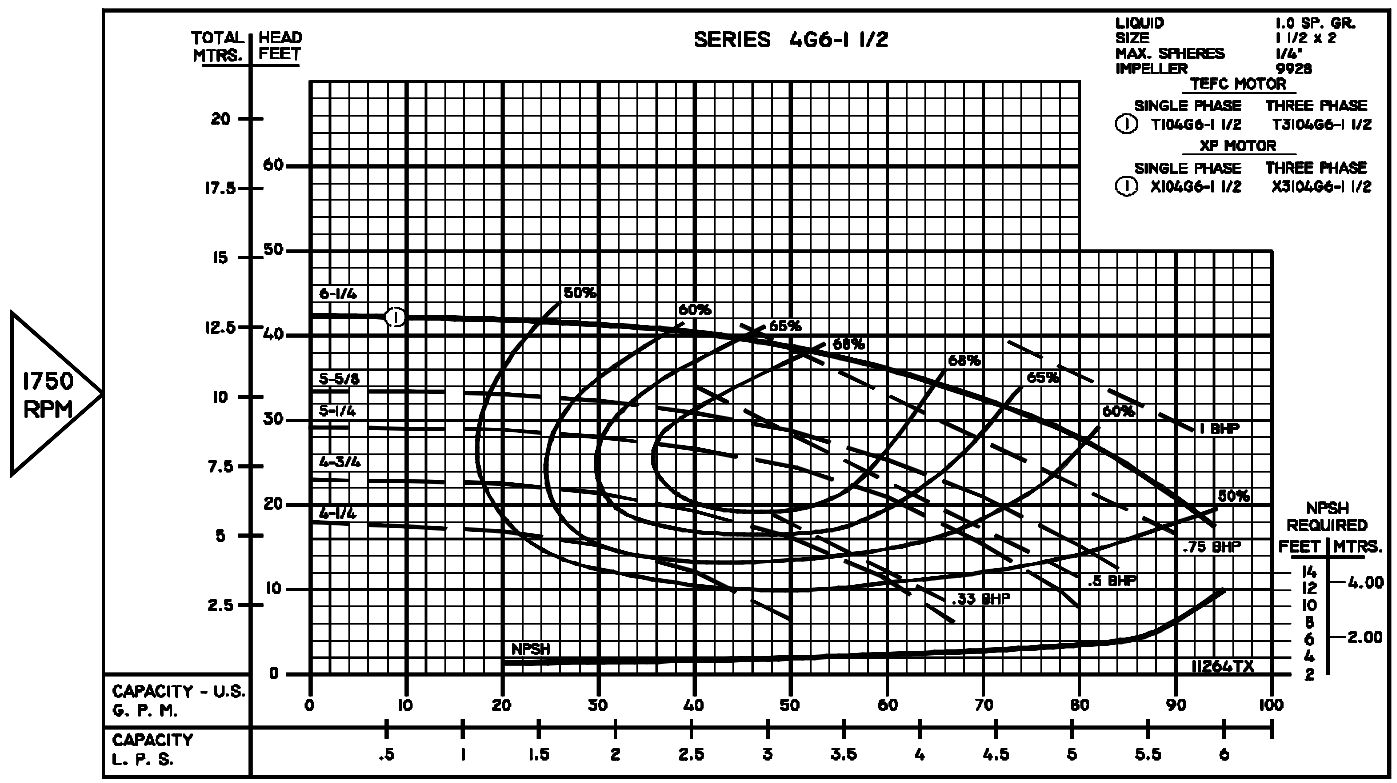
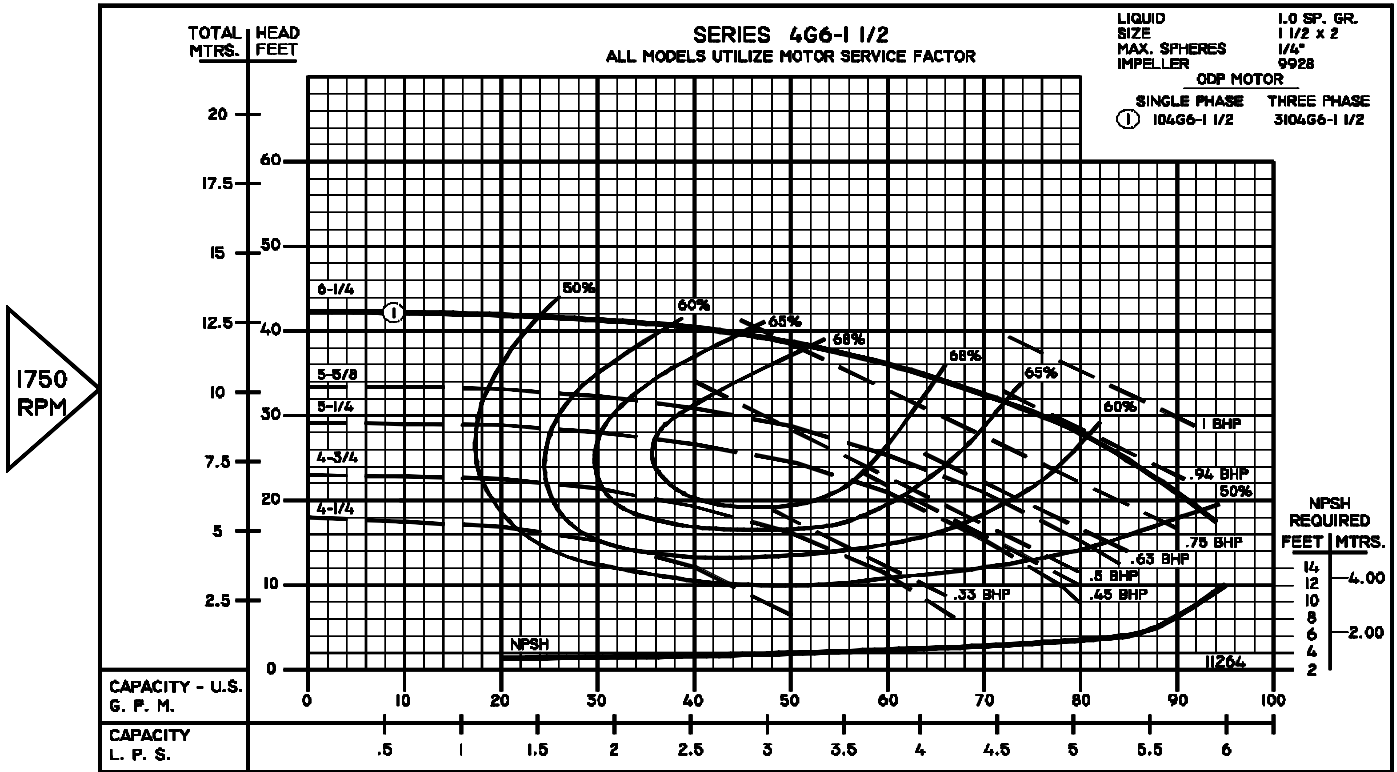

PUMPS & SYSTEMS



60HZ
PERFORMANCE CURVE

SECTION	2B
PAGE	23
ISSUED	2/03
REPLACES	12/01

END SUCTION CENTRIFUGAL PUMPS

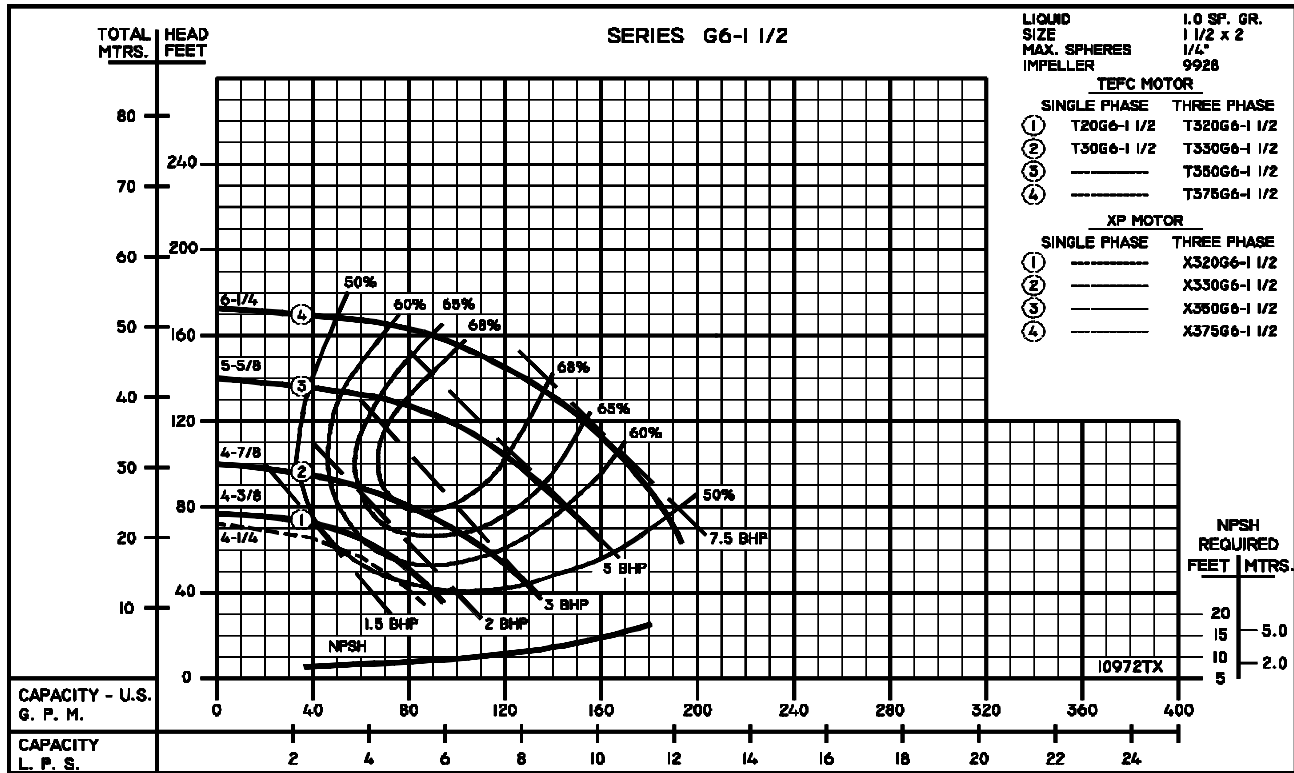
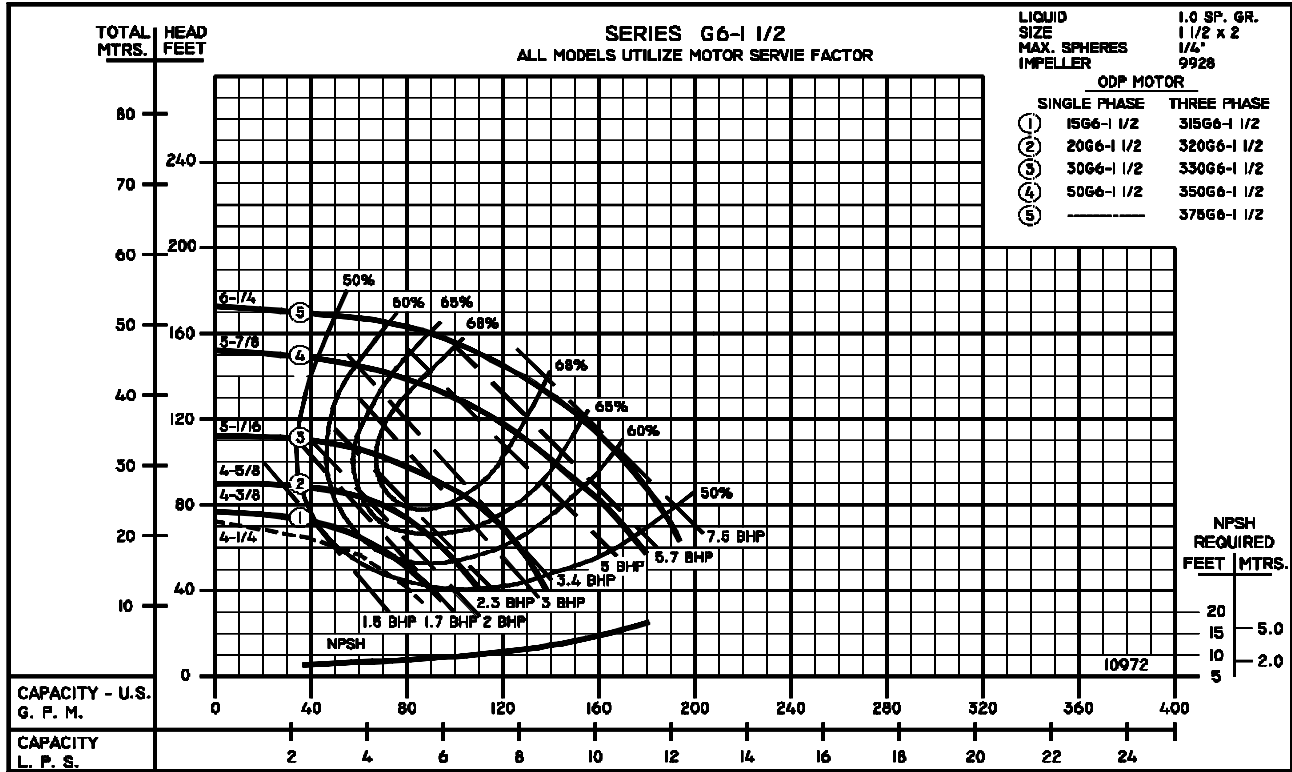

CCCP-22

1 - MOTORS			
RPM & PHASE	PART NUMBER	HP	FRAME SIZE
OPEN DRIP PROOF			
1750 RPM Single Phase (ODP)	21393	1	143JM
	21394	1-1/2	145JM
1750 RPM Three Phase (ODP)	21419	1	143JM
	21420	1-1/2	145JM
3500 RPM Single Phase (ODP)	09899	1-1/2	143JM
	09900	2	145JM
	09901	3	182JM
	09902	5	184JM
3500 RPM Three Phase (ODP)	09903	1-1/2	143JM
	09904	2	145JM
	09905	3	145JM
	09906	5	182JM
	09907	7-1/5	184JM
	09999	10	213JM
TOTALLY ENCLOSED			
1750 RPM Single Phase (TEFC)	21399	1	143JM
	21400	1-1/2	145JM
	21401	2	182JM
1750 RPM Three Phase (TEFC)	21426	1	143JM
	21427	1-1/2	145JM
	21428	2	145JM
3500 RPM Single Phase (TEFC)	21880	2	145JM
	21881	3	182JM
	22283	5	213JM
3500 RPM Three Phase (TEFC)	09948	2	145JM
	09947	3	182JM
	09950	5	184JM
	09951	7-1/2	231JM
	20000	10	215JM
EXPLOSION PROOF			
1750 RPM Three Phase (XP)	21433	1	143JM
	21434	1-1/2	145JM
	21435	2	145JM
	21436	3	182JM
	21437	5	184JM
	21438	7-1/2	213JM
3500 RPM Three Phase (XP)	09952	2	145JM
	09953	3	182JM
	09954	5	184JM
	09955	7-1/2	213JM
	20001	10	215JM

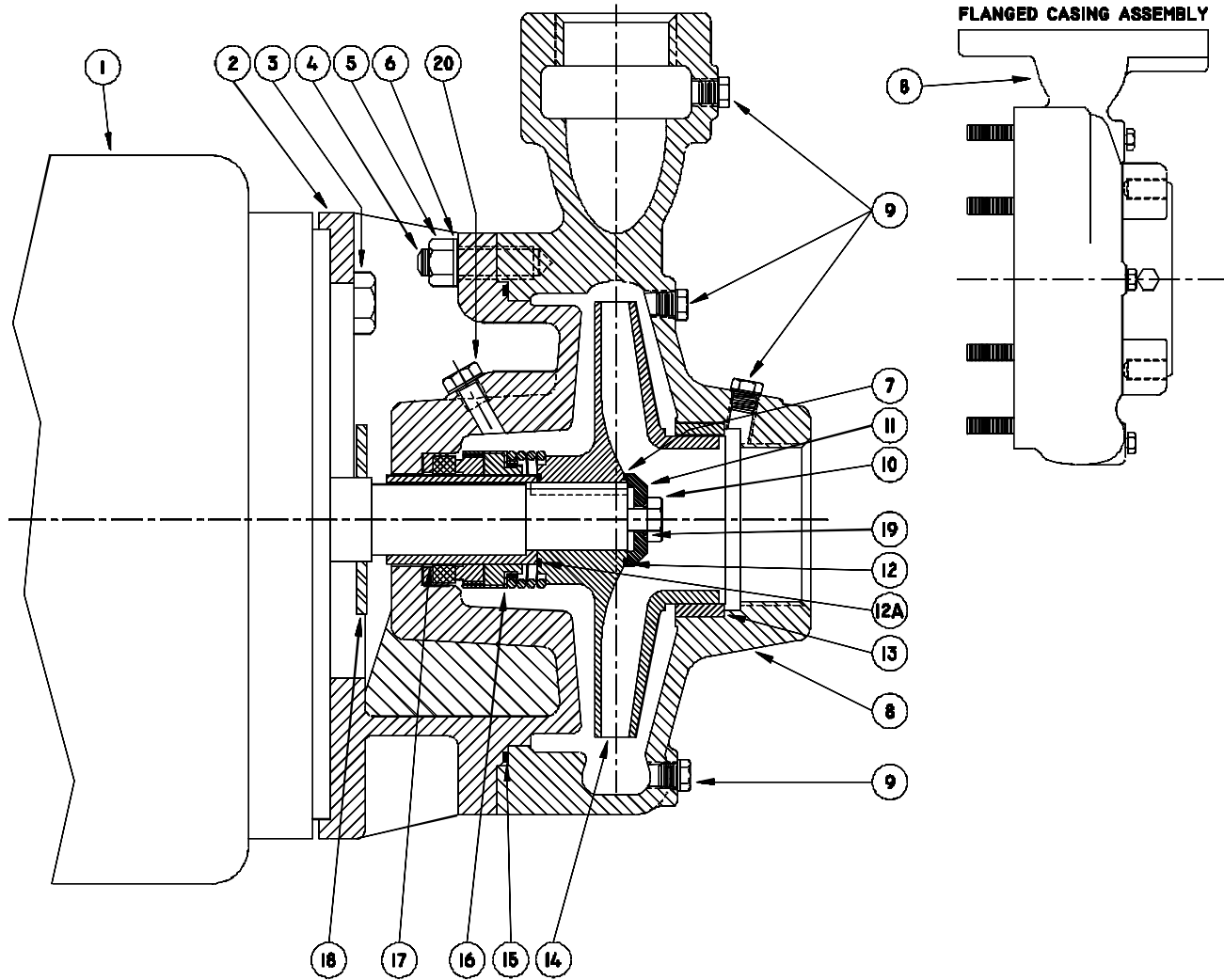

SERIES: G6-1-1/2 & G6-2 CENTRIFUGAL PUMPS

File: G6-150.dwg

SYMBOL NUMBER	PART NUMBER	QUANTITY	DESCRIPTION
2	09912	1	Adapter - 143-184JM Motors
	09920	1	Adapter - 213-215JM Motors
3	01928	4	Cap Screw - for 9912 Adapter
	1-68-6	4	Cap Screw - for 9920 Adapter
4	03075	8	Stud
5	15-23-6	8	Nut
6	01609-A	8	Washer
7	23014	1	Key
* 8	22150	1	Casing Assy - G6-1-1/2
	22151	1	Casing Assy - G6-2
	22269	1	Casing Assy - G6-2F (Flanged)
9	01691-A	6	Pipe Plug, 1/8" - Bronze
10	1-529-1	1	Screw, Impeller Lock - S.S.
11	22105-C	1	Washer - Bronze
12	09933	1	Flat Gasket +
	22083	2	O-Ring Gasket - Buna N (Std)
	22084	2	O-Ring Gasket - Viton
	22094	2	O-Ring Gasket - EPT*
	22085	2	O-Ring Gasket - Teflon
12A	09911	1	Flat Gasket +
	For O-Ring Gasket, See Symbol 12		
13	09915	1	Wear Ring, Bronze - G6-1-1/2
	09923-E	1	Wear Ring, Bronze - G6-2
	1750 RPM		
	09928-6.25	1	Impeller - 104G6-1-1/2 & 3104G6-1-1/2
	09929-6.19	1	Impeller - 104G6-2 & 3104G6-2
	09929-6.25	1	Impeller - 154G6-2 & 3154G6-2
	3500 RPM		
14	09928-4.38	1	Impeller - 15G6-1-1/2 & 315G6-1-1/2
	09928-4.63	1	Impeller - 20G6-1-1/2 & 320G6-1-1/2
	09928-5.06	1	Impeller - 30G6-1-1/2 & 330G6-1-1/2
	09928-5.88	1	Impeller - 50G6-1-1/2 & 350G6-1-1/2
	09928-6.25	1	Impeller - 375G6-1-1/2
	09929-4.13	1	Impeller - 20G6-2 & 320G6-2
	09929-4.75	1	Impeller - 30G6-2 & 330G6-2
	09929-5.38	1	Impeller - 50G6-2 & 350G6-2
	09929-6.06	1	Impeller - 375G6-2
	09929-6.25	1	Impeller - 3100G6-2

SYMBOL NUMBER	PART NUMBER	QUANTITY	DESCRIPTION
15	09916	1	Flat Gasket +
	22099	1	O-Ring Gasket - Buna N (Std)
	23000	1	O-Ring Gasket - Viton
	23001	1	O-Ring Gasket - EPT*
	23002	1	O-Ring Gasket - Teflon
16	09917	1	Mechanical Seal - Buna N (Std)
	09926	1	Mechanical Seal - Viton
	21271	1	Mechanical Seal - EPT **
17	22063-C	1	Shaft Sleeve - Bronze
18	09918	1	Slinger Washer
19	22080	1	O-Ring Gasket - Buna N (Std)
	2-31005-012	1	O-Ring Gasket - Viton
	22093	1	O-Ring Gasket - EPT*
	22082	1	O-Ring Gasket - Teflon
20	04236	1	Pipe Plug, 1/4" - Bronze
DIFFERING PARTS FOR ALL BRONZE CONSTRUCTION			
2	09912-B	1	Adapter-143-184JM Motors
	09920-B	1	Adapter-213-215JM Motors
3	03289	4	Cap Screw - for 9912-B Adapter
	01638-B	4	Cap Screw - for 9920-B Adapter
5	05536	8	Nut
6	1609-B	8	Washer
8	22150-A	1	Casing Assy - G6-1-1/2
	22151-A	1	Casing Assy - G6-2
	22269-A	1	Casing Assy - G6-2F (Flanged)
10	03289	1	Screw, Impeller Lock - Bronze
DIFFERING PARTS FOR ALL IRON CONSTRUCTION			
* 8	22150-B	1	Casing Assy. - G6-1-1/2
	22151-B	1	Casing Assy. - G6-2
	22269-B	1	Casing Assy. - G6-2F (Flanged)
9	00158	6	Pipe Plug
11	22105-A	1	Washer - Steel
13	09915-A	1	Wear Ring, G6-1-1/2
	09923-A	1	Wear Ring, G6-2
14	09928-A	1	Impeller - G6-1-1/2
	09929-A	1	Impeller - G6-2
	Use same size suffixes as bronze.		
17	22063-A	1	Shaft Sleeve - S.S.
20	04236-A	1	Pipe Plug, 1/4" - S.S.

SERIES: G6-1-1/2 & G6-2

*Casing Assy. includes Symbols 4, 9 & 13.

** For hot water or caustic service

+ Series G6-1-1/2 and G6-2 pumps have been manufactured with either flat or O ring type gaskets. Determine which type is required before ording. When in doubt, order flat gaskets.

CCCP-23

For technical advice or service please take your pump into your local pump service center.
To order pump or parts or for pricing please go to the following links :

[Burks Pumps Home >>](#)

[Burks Pumps stock list >>](#)