

Please read and save this Repair Parts Manual. Read this manual and the General Operating Instructions carefully before attempting to assemble, install, operate or maintain the product described. Protect yourself and others by observing all safety information. The Safety Instructions are contained in the General Operating Instructions. Failure to comply with the safety instructions accompanying this product could result in personal injury and/or property damage! Retain instructions for future reference. AMT reserves the right to discontinue any model or change specifications at any time without incurring any obligation.

©2017 AMT Pump Company, A Subsidiary of The Gorman-Rupp Company, All Rights Reserved.

Periodic maintenance and inspection is required on all pumps to ensure proper operation. Unit must be clear of debris and sediment. Inspect for leaks and loose bolts. Failure to do so voids warranty.

Patterson/AMT Inline Circulator Pump



Refer to pump manual 1808-634-00 for General Operating and Safety Instructions.

DESCRIPTION

Patterson/AMT inline circulator pumps are designed for continuous duty industrial/commercial applications. Pumps are designed for liquid circulation in HVAC and industrial/commercial systems. Pumps are available in cast iron or bronze configurations to meet your specification. Pumps are powered by a single phase 115V 56J NEMA frame electric motor with 1/2-14 NPSM conduit connection. Pump is equipped with precision lapped mechanical shaft seal to reduce the likelihood of leakage, O-ring sealed casing and a stainless steel closed impeller. Liquid temperature range is 40° to 200° F (4° to 93° C). Liquid viscosity and specific gravity must be close to water; 31 SSU and 1.00. Maximum casing pressure is 150 psi. Pump shipped without NPT connection flanges or flange gaskets. Connection flange kits must be ordered separately.

All 115V motors are equipped with automatic thermal protection. Check motor wiring before putting unit into service (see motor nameplate for specific wiring diagram). These are manual units, no controls are supplied. All units are for use with non-flammable, non-abrasive liquids, compatible with pump component materials.

▲ WARNING

All units are for use with non-flammable, non-abrasive liquids compatible with pump component materials.

IMPORTANT: Not for use with petroleum based liquids.

CAST IRON UNITS (-95)

Pump construction is cast iron casing and adapter. Cast stainless steel impeller; 5720 models with cast bronze impeller. EPDM mechanical shaft seal with carbon and ceramic wear faces. EPDM O-ring casing seal.

BRONZE UNITS (-97)

Pump construction is cast bronze casing and adapter. Cast stainless steel impeller; 5720 models with cast bronze impeller. EPDM mechanical shaft seal with carbon and ceramic wear faces. EPDM O-ring casing seal.

UNPACKING

Refer to Repair Parts Illustration and Repair Parts List to aid in identifying parts. Unpack and separate all pump components from shipping/packaging materials making sure all parts are accounted for. Retain all manuals for reference. Package should contain: pump, circulator pump specific manual and general pump manual.

INSTALLATION

1. Pump is designed for circulating liquid in a closed system for a flooded suction application. Pump will not self-prime.
2. Piping system must be designed for adequate thermal expansion.
3. A pressure relief valve should be considered to protect pump casing from over pressurization and pressure spikes, especially if a check valve is installed near pump.
4. Locate the pump so that there is sufficient room for maintenance and servicing.
5. There must be a sufficient supply of cooling air and ventilation around the pump and motor to avoid excessive component temperatures.
6. Installing a shutoff valve in both the suction and discharge piping will

make removal and servicing of the pump possible without draining the entire system.

7. Support the piping near the pumps suction and discharge with sufficient piping hangers. This will minimize pipe strain.

NOTE: Proper motor support is required to avoid damage to pump or motor. Use correct size motor hanger similar to the one pictured based on model being installed. Hangers vary depending on horizontal or vertical installation (see figure 1).



Figure 1 - Piping Hanger & Support

8. Make sure bolt holes in pipe flange line up with bolt holes in pump flange.

▲ CAUTION

Do not spring the suction or discharge piping into position. This will result in excessive strain in the piping, flanges and pump casing.

ORIENTING PUMP

1. The pump can be oriented in any desired position: discharge up or down, left or right.
2. If motor is oriented vertically up, a means of venting air from the seal chamber must be installed in the adapter (Ref. No. 2) 1/8" NPT port. Remove 1/8" NPT plug (Ref. No. 12) and install air venting device or liquid injection line.
3. **DO NOT INSTALL UNIT** with motor vertically down, any liquid breaching the mechanical shaft seal will run directly down shaft into motor.

NOTE: Proper motor support is required to avoid damage to pump or motor. Use correct size motor hanger similar to the one pictured above based on model being installed. Hangers vary depending on horizontal or vertical installation (see figure 1).

Patterson/AMT Inline Circulator Pump

INSTALLING FLANGES

1. Included with flange kit (sold separately): 2 NPT flanges, 2 gaskets and hardware.
2. Install flanges on piping using sealing tape or pipe sealant.
3. Insert gasket into machined groove on pump flange.
4. Position pump by lining up bolt holes on pump flange with bolt holes on pipe flange.
5. Install hardware. Torque flange bolts in even increments to a value of 8-11 ft-lbs (1.1-1.5 Kg-m). Torque the bolts in both the suction and discharge flanges in this manner.

OPERATION

1. Prior to pump start up be sure system is clean and filled with clean liquid that is compatible with pump components.
2. Pressurize the pump body slowly. Check for leaks at the flange joint, the pump casing and motor shaft.

⚠ CAUTION

Pressurize pump casing slowly. Failure to check for leaks at all joints sealed with a gasket may result in personal injury or property damage.

3. Do not run pump dry! Mechanical shaft seal damage will occur if pump is run dry. Pump body must be filled with liquid before starting motor. Air must be vented from the system by means of an air vent located at a high point in the system.

MAINTENANCE

⚠ WARNING

Make certain that the unit is disconnected and locked out from the power source before attempting to service or remove any components.

1. System must be drained or pump isolated by turning off suction and discharge valves before attempting to remove pump.

⚠ WARNING

Water temperature in system cannot exceed 100°F (38°C) before removing or servicing pump. If draining system, leave drain valve open during servicing.

⚠ CAUTION

Pump surface temperature cannot exceed 90°F (32°C) before removing or servicing pump.

⚠ WARNING

Loosen flange bolts slightly and shift pump side to side to vent internal pump casing pressure before removing or servicing pump.

2. Remove pump from the system by removing flange mounting hardware.

SHAFT SEAL REPLACEMENT

Refer to figure No. 2

REMOVAL OF OLD SEAL

IMPORTANT: Always replace both seal seat (Ref. No. 4) and seal head (Ref. No. 5) to ensure proper mating of components! Also, impeller seal (Ref. No. 7) should be replaced anytime impeller fastener (Ref. No. 8) has been removed.

1. Remove fasteners (Ref. No. 11) connecting casing (Ref. No. 9) to adapter (Ref. No. 2).

2. Remove casing. If casing is hard to slide off, use a large flat screwdriver to pry between cast boss next to casing bolt boss and adapter flange. Take care not to mar adapter flange machined surface.

⚠ CAUTION

Care should be taken not to pinch or "shave" casing seal (Ref. No. 3) between adapter and casing.

3. Use a box and/or socket wrench to remove impeller fastener. Remove impeller seal and impeller (Ref. No. 6).

NOTE: Motor shaft must be held in place to remove impeller. Back of the motor either has slot in shaft (use large screwdriver to hold) or has 2 flats on motor shaft (use 7/16 open end wrench to hold). Impeller and impeller fastener unscrew CCW when looking at the bottom of casing.

4. The seal head can now be pulled from shaft.
5. Remove fasteners (Ref. No. 10) connecting adapter (Ref. No. 2) to motor (Ref. No. 1). Using a flat head screw driver, push seal seat from adapter.

INSTALLATION OF NEW SEAL

⚠ CAUTION

The precision lapped faces on mechanical seal are easily damaged. Handle your repair seal carefully. Do not touch polished seal faces.

IMPORTANT: Be sure that shaft does not damage polished face (See figure 2).

1. Thoroughly clean all surfaces of seal cavity in adapter.
2. Using a clean cloth, wipe shaft and make certain that it is perfectly clean.
3. Wet rubber portion of new seal seat with a light coating of soapy water. While wearing clean gloves or using a clean light rag, press seal seat squarely into adapter recess. Use cardboard washer (usually supplied with new seal), place over polished surface and use a piece of pipe or dowel rod to press in firmly but gently. Avoid scratching polished face.
4. Dispose of cardboard washer. Check again to see that polished face is free of dirt and all other foreign particles and that it has not been scratched or damaged.
5. Install adapter on motor. Tighten all fasteners evenly.
6. Wet the inside rubber portion of new seal head with a light coating of soapy water. Slide head onto motor shaft with sealing surface facing seal seat (see figure 2).

NOTE: A short "run-in" period may be necessary to provide completely leak-free operation.

7. Screw impeller onto shaft. Use screwdriver slot at rear of motor shaft (opposite the threaded end) to tighten impeller.

NOTE: It may be necessary to remove plug in motor end cap to expose slot. If removed, be sure to reinstall plug AFTER pump is completely assembled.

8. Check if shaft turns freely by spinning impeller.
9. Slide impeller seal onto exposed shaft. Screw acorn nut onto shaft and tighten.
10. Place casing seal in groove on adapter. Wet seal with a light coating of soapy water. Slide casing onto adapter. Set casing in position by taping on casing bottom with a rubber mallet until casing slides by seal and seats on adapter flange.
11. Attach casing using fasteners. Spin motor shaft to check for interference with casing.

Patterson/AMT Inline Circulator Pump

⚠ CAUTION

Seal will produce minor drag when spinning motor shaft, but rubbing anywhere else must be eliminated! Otherwise, damage to pump and/or motor may occur.

PUMP PIPING

1. Proper system design and installation by a qualified engineer is recommended.
2. Always start piping from pump.
3. Use as few bends as possible and preferably long radius elbows.
4. Do not use flexible connectors on the suction or discharge of a vertical inline pump unless the pump is rigidly mounted to a foundation.
5. Ensure piping exerts no strain on pump as this could distort the casing causing breakage or early failure due to pump misalignment.
6. All connecting pipe flanges must be square to the pipe work and parallel to the pump flanges.
7. Eliminate all air pockets that may prevent the pump from operating effectively.
8. In open systems, test suction line for air leaks before starting; this becomes essential with long suction line or static lift.
9. Install valves in both suction and discharge lines to assist with pump inspection or repair. Suction line valve may be opened completely during operation.
10. Install a non-slam non-return check valve in discharge line between pump and isolation valve to protect pump from excessive back pressure and to prevent water running back through the pump on open systems.
11. Before starting pump, the system must be thoroughly cleaned, flushed and drained and replenished with clean liquid.
12. Welding slag and other foreign materials, improper or excessive water treatment are all detrimental to the pump internals and sealing arrangement and void warranty.
13. Proper operation cannot be guaranteed if the above conditions are not adhered to.

NOTE: INSPECT THE FOLLOWING BEFORE PUTTING PUMP INTO OPERATION:

1. Pump primed; liquid in pump.
2. Rotation.
3. System piping and pump properly supported.
4. System clean of all debris.
5. Proper electrical connections. Consult qualified electrician with any questions.
6. Proper motor support is required to avoid damage to motor or pump see page 1, Installation & orienting sections

IMPORTANT: SYSTEM MUST BE FREE OF ALL PETROLEUM BASED LIQUID OR SUBSTANCE TO AVOID SEAL FAILURE, WHICH CAN ALSO LEAD TO PREMATURE MOTOR BEARING FAILURE. FAILURE TO COMPLY VOIDS WARRANTY.

Patterson/AMT Inline Circulator Pump

For Repair Parts contact dealer where pump was purchased.

Please provide following information:

-Model Number

-Serial Number (if any)

Part description and number as shown in parts list

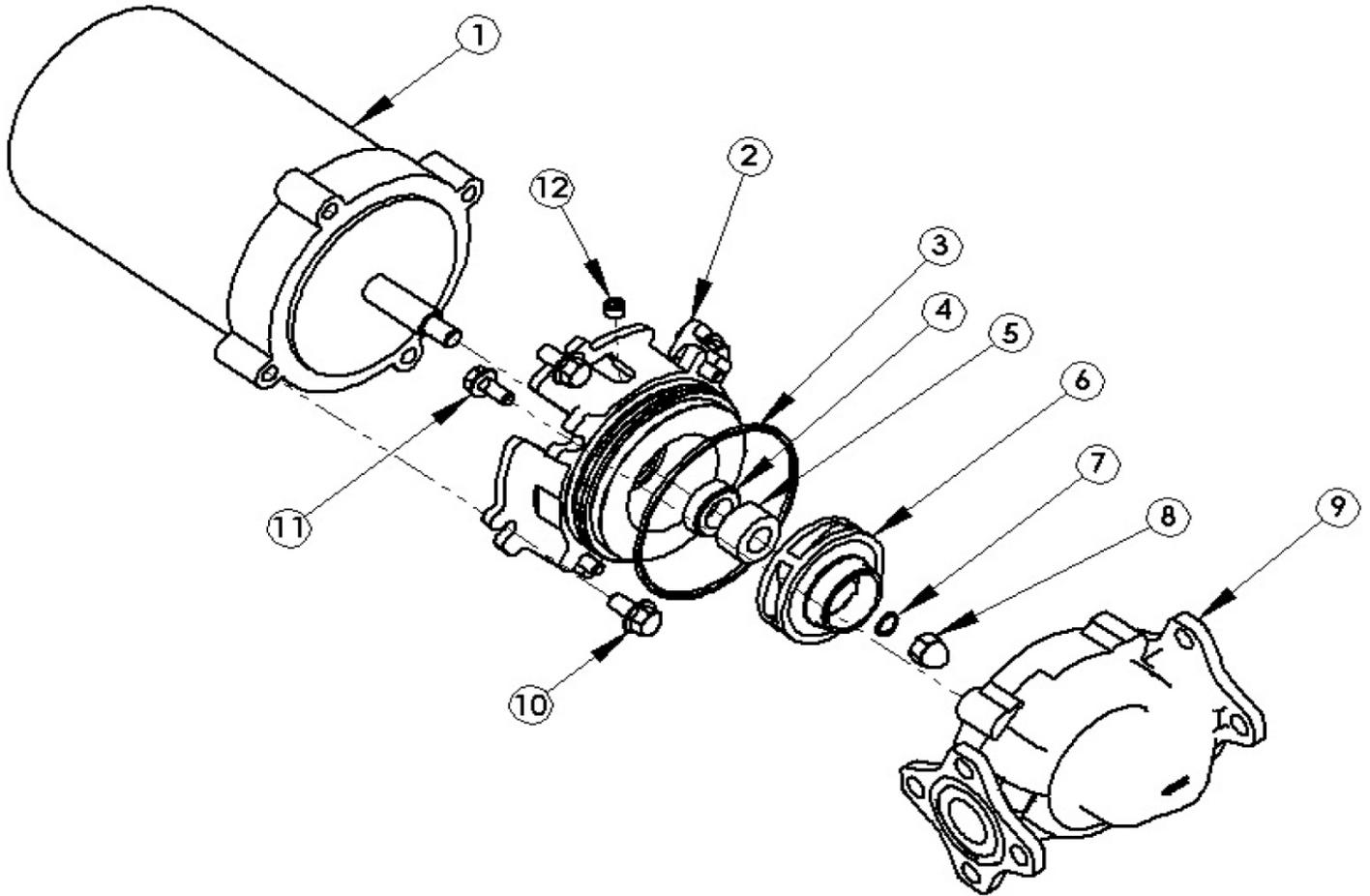

Figure 2 - Repair Parts Illustrations

Repair Parts List

Ref		Part Number for Models								Qty
No.	Description	5690-95	5690-97	5700-95	5700-97	5710-95	5710-97	5720-95	5720-97	
1	Motor	1626-096-00	1626-096-00	1626-096-00	1626-096-00	1626-096-00	1626-096-00	1626-096-00	1626-096-00	1
2	Adapter	5690-031-00	5690-032-00	5690-031-00	5690-032-00	5690-031-00	5690-031-00	5690-031-00	5690-032-00	1
3	O-Ring EPDM	See Ref.13	See Ref.13	See Ref.13	See Ref.13	See Ref.13	See Ref.13	See Ref.13	See Ref.13	1
4&5	Shaft Seal Assembly	See Ref.13	See Ref.13	See Ref.13	See Ref.13	See Ref.13	See Ref.13	See Ref.13	See Ref.13	1
6	Impeller	5690-010-01	5690-010-01	5700-010-01	5700-010-01	5710-010-01	5710-010-01	5701-010-00	5701-010-00	1
7	O-Ring EPDM	See Ref.13	See Ref.13	See Ref.13	See Ref.13	See Ref.13	See Ref.13	See Ref.13	See Ref.13	1
8	7/16-20 Acorn Nut	1784-001-00	1784-001-00	1784-001-00	1784-001-00	1784-001-00	1784-001-00	1784-001-00	1784-001-00	1
9	Casing	5690-001-01	5690-002-01	5700-001-00	5700-002-00	5710-001-00	5710-002-00	5700-001-00	5700-002-00	1
10	3/8-16 x 1" Hex Flange Bolt	*	*	*	*	*	*	*	*	4
11	5/16-18 x 3/4" Hex Fl Bolt	*	*	*	*	*	*	*	*	4
12	1/8" Pipe Plug	*	*	*	*	*	*	*	*	1
13	Seal Kit - EPDM (standard)	5690-301-KT	5690-301-KT	5700-301-KT	5700-301-KT	5700-301-KT	5700-301-KT	5700-301-KT	5700-301-KT	1
	Seal Kit - Buna (optional)	5690-300-KT	5690-300-KT	5700-300-KT	5700-300-KT	5700-300-KT	5700-300-KT	5700-300-KT	5700-300-KT	1
	Seal Kit - Viton (optional)	N/A	N/A	5700-302-KT	5700-302-KT	5700-302-KT	5700-302-KT	5700-302-KT	5700-302-KT	1
	(includes Ref. Nos. 3, 4, 5, 7, and 14)									
14	Flange Gasket (not shown)	See Ref.13	See Ref.13	See Ref.13	See Ref.13	See Ref.13	See Ref.13	See Ref.13	See Ref.13	1

(*) Standard hardware item, available locally.