

Please read and save this Repair Parts Manual. Read this manual and the General Operating Instructions carefully before attempting to assemble, install, operate or maintain the product described. Protect yourself and others by observing all safety information. The Safety Instructions are contained in the General Operating Instructions. Failure to comply with the safety instructions accompanying this product could result in personal injury and/or property damage! Retain instructions for future reference. AMT reserves the right to discontinue any model or change specifications at any time without incurring any obligation.

©2013 American Machine & Tool Co., Inc. of PA, A Subsidiary of The Gorman-Rupp Company, All Rights Reserved.

Periodic maintenance and inspection is required on all pumps to insure proper operation. Unit must be clear of debris and sediment. Inspect for leaks and loose bolts. Failure to do so voids warranty.

# Vertical Sealless Sprayer/Washer Pumps



A Gorman-Rupp Company

Refer to pump manual 1808-634-00 for General Operating and Safety Instructions.

## DESCRIPTION

Vertical sealless sprayer/washer pumps are heavy duty industrial units designed for OEM, automotive and industrial washing machines, parts cleaners, spray booths and cooling towers. Pumps are immersion type; pump end must be immersed in liquid, motor must remain above liquid surface.

All models feature 316 stainless steel semi-open clog resistant impeller, stainless steel shaft, steel shaft coupling, cast iron base and column, plated steel inlet screen, and a TEFC (Totally Enclosed Fan Cooled) electric motor. Motor has ball bearings. Heavy duty steel universal mounting brackets included. Pump design eliminates a bottom bearing and a shaft seal on all models. Pumps handle liquids up to a maximum temperature of 200° F. Maximum ambient temperature 104° F. Liquid viscosity cannot exceed 100 SSU. These are manual units; no controls are supplied. For use with nonflammable liquids compatible with pump component materials.

## INSTALLATION

1. (5570 series pumps) Remove shipping fixture (Ref. No. 19) that holds the drive shaft to the base before installing pump.
2. Pump must be installed with its base supporting the entire weight of the pump.

### ▲ CAUTION

**Mounting brackets are not designed to support the pump's weight. Brackets are designed to prevent tipping.**

3. Position pump in tank or reservoir. Position mounting brackets, align pipe clearance hole with pump discharge outlet.
4. (4445 series pumps) Assemble one piece of sponge tape (Ref. No. 25) to each clamp bracket (Ref. No. 24). Attach clamp brackets to mounting brackets with fasteners provided (Ref. Nos. 26 and 27). This will fix the column (Ref. No. 3) in position.
5. (5570 series pumps) Adjust lower fasteners (Ref. No. 4) to bottom of mounting brackets. Secure pump to mounting brackets with upper fasteners (Ref. No. 4).
6. Secure mounting brackets to tank or reservoir. Install an appropriate fastener in each hole or slot provided.
7. Install the balance of the system.

## MAINTENANCE

### ▲ WARNING

**Make certain that unit is disconnected from power source before attempting to service or remove any component.**

## IMPELLER/MOTOR REPLACEMENT

Refer to Figure 2, and 3.

1. Remove unit from the tank or reservoir.
2. Remove fasteners (Ref No. 8) and washers if present (Ref. No. 7) that connect the volute base (Ref. No. 17) to the volute cover (Ref. No. 10).
3. Remove volute base, and gasket (Ref. No. 16).
4. Place an allen wrench through the slot in the top of the column and into one of the socket head screws of the shaft coupling. Rotate impeller counterclockwise until allen wrench stops against side of slot. Remove nut (Ref. No. 15) and then impeller from drive shaft by rotating each counterclockwise.

**IMPORTANT:** Care should be taken to insure that same number of shim washers (Ref. No. 9), if present, is replaced behind impeller as were removed. These shim washers are located directly behind the impeller. Shim washers may or may not be present depending on assembly clearances.

5. Remove allen wrench from slot and then remove the four fasteners (Ref. No. 5) and washers or nuts (Ref. No. 4) that connect the motor (Ref. No. 1) to the column (Ref. No. 3).
6. Remove the motor with shaft (Ref. No. 13) and coupling (Ref. No. 2) from the column.
7. Measure the distance from the shaft coupling to the motor mounting surface. Record this measurement.
8. Loosen the two socket head screws, towards the motor, in the coupling. Slide the coupling/shaft from the motor.
9. To reassemble, slide the coupling/shaft on the motor. Replace drive key (Ref. No. 7) if removed (557X Series only). Position the coupling at the recorded distance from the motor mounting surface. Securely tighten all four socket head screws in coupling.
10. Install motor/shaft assembly into column. Secure with four

# Vertical Sealless Sprayer/Washer Pumps

fasteners and washers.

11. Install impeller, shim washers if any, and nut. Position gasket on volute cover and install volute base with fasteners and washers.

**IMPORTANT:** If impeller strikes volute spacer plate (Ref. No. 11) before bottoming on shaft shoulder, add two 0.020" shims behind impeller. Reinstall impeller.

12. Place pump in an upright position. Rotate shaft/impeller. Impeller cannot strike volute base or volute cover. If interference exists, install or remove shim washers behind the impeller. (See "SHIM ADJUSTMENT" section) If shimming does not correct interference, repositioning coupling/shaft/impeller assembly on motor shaft may be necessary.

## VOLUTE SPACER PLATE REPLACEMENT

The volute spacer plate is subject to wear only by abrasive liquids. If badly worn this plate can be replaced easily.

1. Disassemble pump for access as described in IMPELLER/MOTOR REPLACEMENT, steps 1, 2, 3, and 4.
2. Remove two fasteners (Ref. No. 12) that connect the spacer plate to the volute cover.
3. Replace spacer plate.
4. Reassemble pump as described in steps 11 and 12.

## SHIM ADJUSTMENT

1. When installing a replacement impeller (Ref. No. 14), motor (Ref. No. 1), volute spacer plate (Ref. No. 11) or volute base (Ref. No. 17), it may be necessary to adjust the number of shims (Ref. No. 9) to insure proper running clearance between impeller and volute base and spacer plate. Proceed as follows:

**NOTE: A proper running clearance between impeller and volute base is 0.04" to 0.06".**

- a. For impeller or motor replacement, add one 0.020" shim in addition to those removed, if any, originally.
- b. Reassemble pump as described in steps 9, 10, 11, and 12 as described in IMPELLER/MOTOR REPLACEMENT.

**IMPORTANT:** Insure that volute base is snugly in place and check shaft to make sure it is turning freely (rotate impeller by using impeller nut Ref. No. 15 and socket wrench). Tighten fasteners connecting motor to column and volute to base carefully. Rotate shaft while tightening so that motor bearings are not damaged in the event that too many shims were installed. If shaft seizes before fasteners are completely tight, disassemble pump and remove two shims and repeat assembly.

## SHAFT SUPPORT REMOVAL

Models 4445-95 and 4446-95 only. These units are designed to operate without a bottom bearing. A shaft support (Ref. No. 20) is installed at the factory to protect the shaft from misalignment during shipping. If pump is noisy while operating, this support may be the cause. The shaft support can be removed to stop noisy operation. Shaft support should not be replaced.

1. Disassemble pump for access as described in IMPELLER/MOTOR REPLACEMENT, steps 1 through 6.
2. Press out shaft support. Do not remove support plate (Ref. No. 21).
3. Reassemble pump as described in steps 10, 11, and 12.

## DEBRIS SCREEN CLEANING

Sprayer/Washer pumps are equipped with a debris screen (Ref. No. 18). This screen is supplied attached to volute base (Ref. No. 17) with 4 drive pins. This screen may be replaced if damaged.

If pump performance is reduced or severe vibration occurs during operation this screen may be clogged. Debris screen must be thoroughly cleaned to restore pump performance.

# Vertical Sealless Sprayer/Washer Pumps

**For Repair Parts contact dealer where pump was purchased.**

*Please provide following information:*

*-Model Number*

*-Serial Number (if any)*

*Part description and number as shown in parts list*

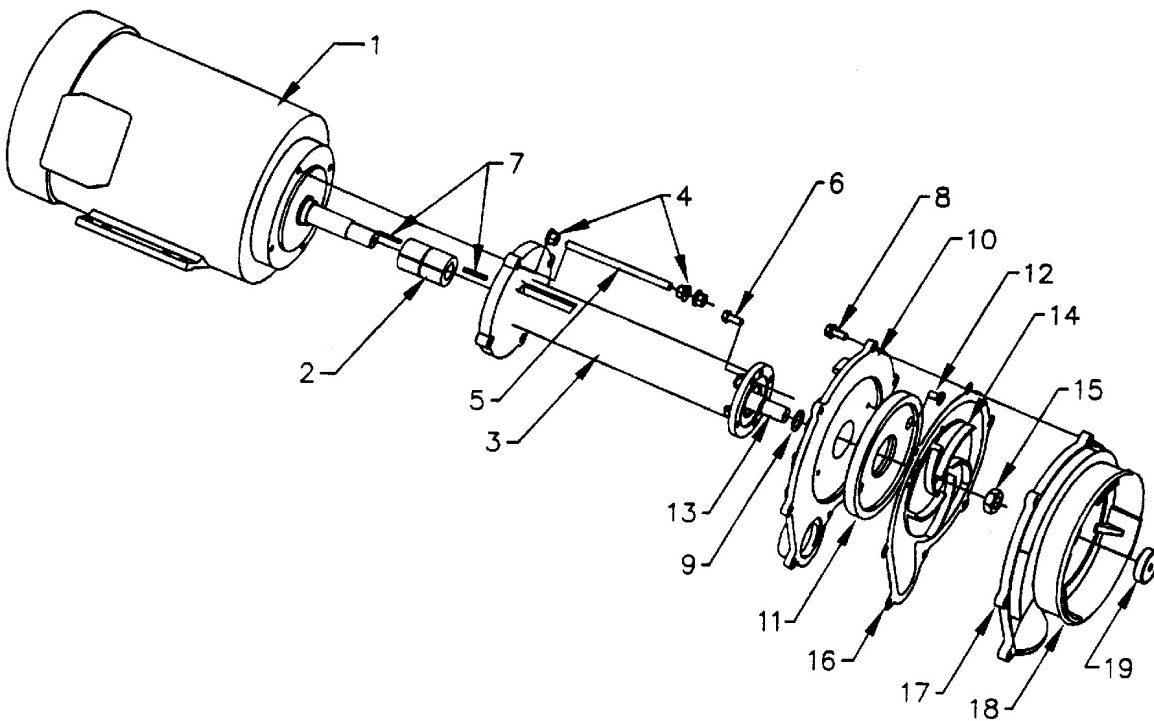

Figure 2 - Repair Parts Illustrations

## Repair Parts List

Ref No.	Description	Part Number for Models			Qty
		5570-95	5571-95	5572-95	
1	Motor	1626-046-00	1626-353-00	1626-352-00	1
2	Coupling	5570-141-00	5570-141-00	5570-141-00	1
3	Column	4430-032-01	4430-032-01	4430-032-01	1
4	Fastener	*	*	*	12
5	Fastener	*	*	*	4
6	Fastener	*	*	*	3
7	Drive Key	1471-030-00	1471-030-00	1471-030-00	2
8	Fastener	*	*	*	7
9	Impeller Shim Kit	1806-090-90	1806-090-90	1806-090-90	1
10	Volute	5570-020-01	5570-020-01	5570-020-01	1
11	Volute Spacer Plate	5570-060-01	5570-060-01	5570-060-01	1
12	Fastener	*	*	*	2
13	Shaft	5570-140-00	5570-140-00	5570-140-00	1
14	Impeller	5570-011-01	5570-011-02	5570-012-01	1
15	Impeller Nut	*	*	*	1
16	Gasket	5570-300-00	5570-300-00	5570-300-00	1
17	Volute Base	4970-001-01	4970-001-01	4970-001-01	1
18	Debris Screen	5570-050-00	5570-050-00	5570-050-00	1
19	Shipping Fixture	N/A	N/A	N/A	1
△	Drive Pin	1697-000-00	1697-000-00	1697-000-00	4
△	Mounting Cover	5570-040-00	5570-040-00	5570-040-00	2

(△) Not Shown

(\*) Standard hardware item, available locally.

(N/A) Not Available