

Please read and save this Repair Parts Manual. Read this manual and the General Operating Instructions carefully before attempting to assemble, install, operate or maintain the product described. Protect yourself and others by observing all safety information. The Safety Instructions are contained in the General Operating Instructions. Failure to comply with the safety instructions accompanying this product could result in personal injury and/or property damage! Retain instructions for future reference. AMT reserves the right to discontinue any model or change specifications at any time without incurring any obligation.

©2015 AMT Pump Company, A Subsidiary of The Gorman-Rupp Company, All Rights Reserved.

Periodic maintenance and inspection is required on all pumps to insure proper operation. Unit must be clear of debris and sediment. Inspect for leaks and loose bolts. Failure to do so voids warranty.

1 1/2-Inch High Pressure Pumps



Refer to pump manual 1808-633-00 for General Operating and Safety Instructions.

DESCRIPTION

These self-priming (to 20 ft. lift) high pressure engine driven pumps are equipped with two 316 stainless steel high performance impellers and a Buna-N mechanical seal to prevent leakage, coupled to a 4-cycle gasoline engine. The pump is designed for higher pressure applications such as lawn sprinkling, spraying irrigation, also, draining and general dewatering applications. Handles liquids from 40° to 180° F (4° to 82° C). For use with non-flammable liquids, compatible with pump component materials.

MAINTENANCE

⚠ WARNING

To prevent accidental starting always remove spark plug, or disconnect and ground spark plug wire before attempting to service or remove any component.

MECHANICAL SEAL REPLACEMENT

Refer to Figures 1 & 2.

IMPORTANT: Always replace both seal seat and seal head to ensure proper mating of components!

1. Unthread fasteners (Ref. No. 19) and remove pump casing (Ref. No. 17) from adapter (Ref. No. 3).
2. Unthread fasteners (Ref. No. 15) and remove suction inlet (Ref. No. 4) from diffuser (Ref. No. 5).
3. Unthread fastener (Ref. No. 9) from stub shaft (Ref. No. 2).

NOTE: To loosen fastener (Ref. No. 9), place an allen wrench in one fasteners in collar (Ref. No. 8) to prevent shaft from turning.

4. Unscrew first stage impeller (Ref. No.1) from stub shaft (impeller unscrews CCW looking at stub shaft).

NOTE: A strap wrench is recommended to loosen both impellers. Attempts to loosen impellers with other tools may cause permanent damage to impellers. Due to close running fits between parts, damaged impellers should be replaced before reassembly of pump.

5. Unthread fasteners (Ref. No. 15) and remove diffuser (Ref. No. 5) and diffuser/crossover (Ref. No. 6) from adapter (Ref. No. 3) as a unit.

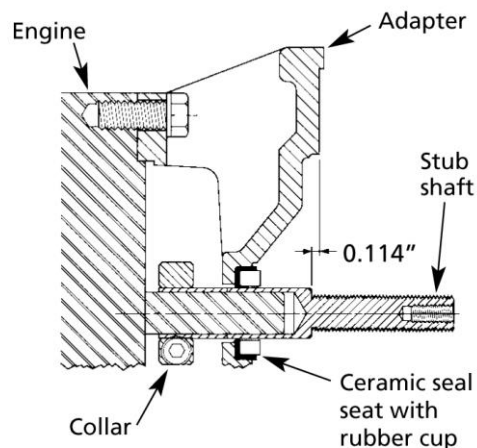

Figure 1 - Mechanical Seal Replacement

6. Remove shaft sleeve (Ref. No. 7) from stub shaft and unscrew second stage impeller (Ref. No. 1).
7. Remove seal head (Ref. No. 12) from stub shaft.
8. Unscrew fasteners (Ref. No. 22) and remove adapter from motor mounting face.
9. Push seal seat (Ref. No. 11) from adapter recess with screwdriver.
10. Clean adapter recess before inserting new seal seat.
11. Carefully wipe seal face surface of new seal seat with clean cloth.
12. Wet rubber portion of new seal seat with a light coating of soapy water.
13. Press new seal seat squarely into adapter recess. If seal seat does not press squarely into recess, it can be adjusted in place by pushing on it with a piece of pipe. Always use a piece of cardboard between pipe and seal seat to avoid scratching seal seat. (This is a lapped surface and must be handled very carefully.)
14. After seal seat is in place, ensure that it is clean and has not been marred.
15. Using a clean cloth, wipe stub shaft and make certain that it is perfectly clean.

NOTE: The stub shaft position is factory set to provide proper seal and impeller location. Do not loosen the collar (Ref. No. 8) or remove stub shaft during mechanical seal replacement or entire rotor will need resetting during reassembly. (See ROTOR ADJUSTMENT on next page.)

16. Carefully guide seal seat over stub shaft and secure adapter (Ref. No. 3) to motor mounting face.
17. Apply a light coating of soapy water to inside rubber portion of seal head (Ref. No. 12) and slide onto stub shaft (with polished sealing face first) so that rubber portion is just over shoulder at end of threads on stub shaft.

⚠ CAUTION

Do not touch or wipe polished face of seal head.

18. Screw second stage impeller back in place and tighten using a strap wrench on impeller shroud opening until the impeller is against stub shaft shoulder.

NOTE: A strap wrench is required to tighten both impellers. Use of any other kind of tool could permanently damage impeller and cause damage to pump due to close running fits between impellers and diffuser and suction inlet.

19. Slide shaft sleeve (Ref. No. 7) onto stub shaft.
20. Apply small amount of grease or Vaseline on outside shroud of impeller opening and shaft sleeve. Remount diffuser (Ref. No. 5) and diffuser/crossover (Ref. No. 6). Before tightening fasteners, rotate stub shaft and be sure impeller and shaft sleeve are not rubbing on diffuser or diffuser/crossover.
21. Screw first stage impeller into place and tighten with a strap wrench. Install fastener (Ref. No. 9) onto end of stub shaft.

1 ½-Inch High Pressure Pumps

22. Remount suction inlet (Ref. No. 4) and rotate stub shaft to be sure impeller is not rubbing on suction inlet before tightening fasteners.
23. Apply small amount of grease or Vaseline to the outside of the diffuser at the O-ring location and on the flange of the suction inlet. Install the O-ring seals.

IMPORTANT: Always inspect O-ring and gaskets (Ref. Nos. 13 & 21). When cut, cracked or worn, replace them. Wet O-rings with oil or Vaseline when reassembling pump for ease of assembly and to prevent pinching.

24. Remount pump casing (Ref. No. 17).
25. A short "run-in" period may be necessary to provide completely leak-free seal operation.

ROTOR ADJUSTMENT

When installing a replacement impeller (Ref. No. 1), motor (Ref. No. 10), or stub shaft (Ref. No. 2), it will be necessary to adjust rotor setting to ensure proper running clearance between the impellers and the diffusers. Proceed as follows:

NOTE: Proper running clearance on this pump will determine both the hydraulic efficiency and life of mechanical seal. Follow this procedure carefully to maximize both.

1. Rotor is set by loosening collar (Ref. No. 8) and sliding stub shaft (Ref. No. 2) onto or off of motor (Ref. No. 10) shaft. This procedure must be done with pump partially assembled (See MECHANICAL SEAL REPLACEMENT steps 1 through 16).
2. Stub shaft is to be set so face of shaft is between 0.114" from adapter face (See Figure 1).
3. Tighten fasteners on stub shaft collar and recheck running clearance before proceeding with reassembly of pump.
4. Continue with reassembling as in mechanical seal replacement with steps 19 through 26.
5. Always be sure during assembly to rotate impellers and check for parts rubbing before tightening fasteners.

For Repair Parts contact dealer where pump was purchased.

Please provide following information:

- Model Number
- Serial Number (if any)
- Part/Kit Description and Number

NOTE: Parts are available only in kits listed, parts are not available individually.

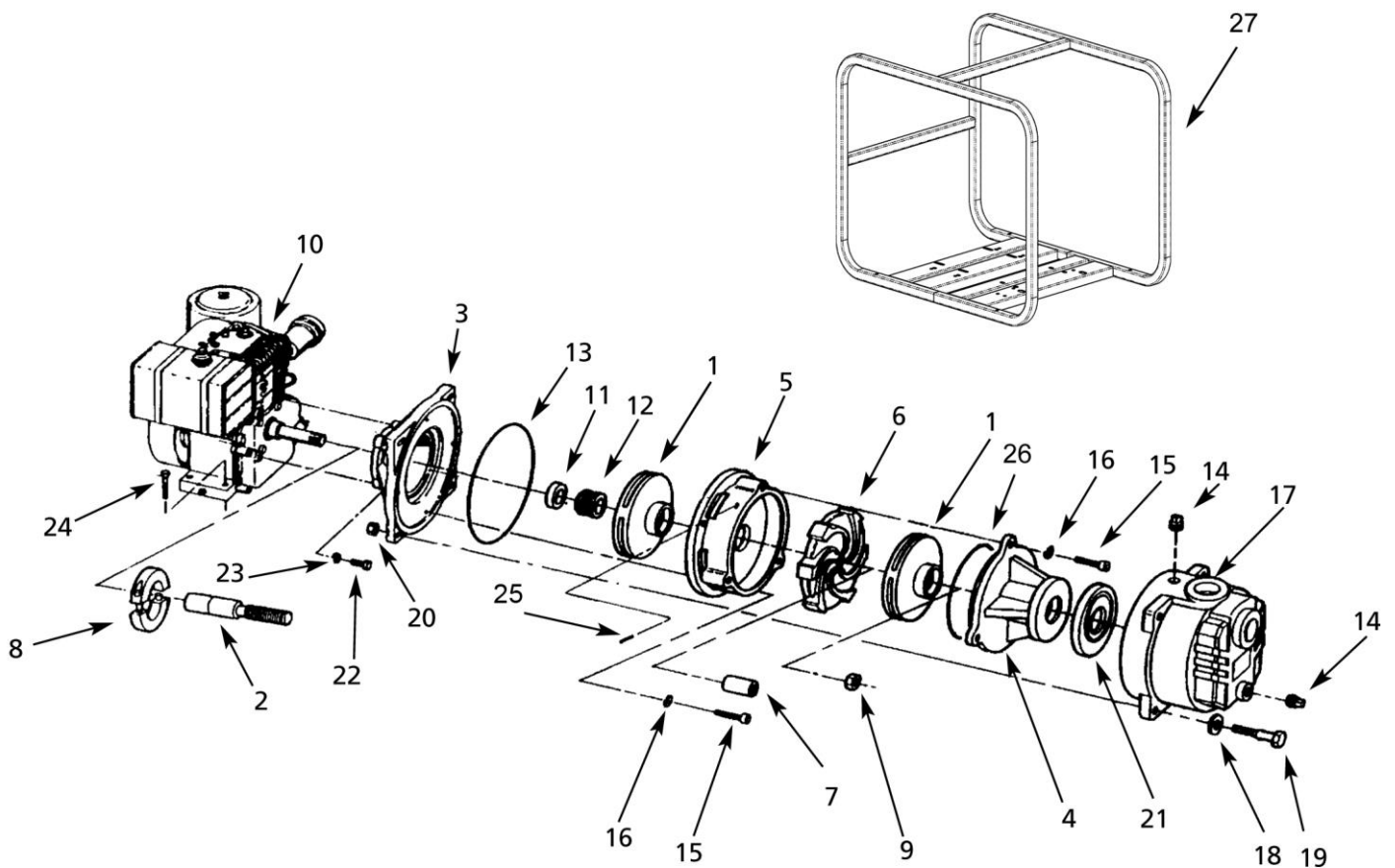

Figure 2 – Repair Parts Illustration

Repair Parts List

Ref. No.	Description	Part Number	Qty.
1	Impeller	4785-011-09	2
2	Stub Shaft	4780-145-00	1
3	Adapter	4788-030-09	1
4	Suction Inlet	4780-220-09	1
5	Diffuser	4780-150-09	1
6	Diffuser/Crossover	4780-155-09	1
7	Shaft Sleeve	4780-141-00	1
8	Collar	2105-012-00	1
9	1/2"-20 UNF Hex Nut	4780-144-00	1
10	Engine - 4783	1639-016-00	1
	Engine - 4787	1639-049-00	1
	Engine - 4788	1639-035-00	1
	Engine - 4789	1639-036-00	1
11 & 12	Shaft Seal Assembly - Buna N	1640-162-96	1
13	Casing Seal - Buna N	1610-000-00	1
14	Pipe Plug	*	2
15	Fastener	*	6
16	Fastener	*	6
17	Casing	2111-001-01	1
18	Washer	*	4
19	Fastener	*	4
20	Fastener	*	4
21	Suction Gasket - Buna N	4780-300-00	1
22	Fastener	*	4
23	Washer	*	4
24	Fastener	*	4
25	#4 x 5/16" Drive Pin	1697-000-00	1
26	Diffuser Seal - Buna N	2103-050-00	1
27	Roll Cage	C403-100-00	1
†	Strainer Kit	C378-999-90	1
†	Wheel Mount Kit w/ 10" Wheels (optional)	A734-999-90	1
†	Wheel Mount Kit w/ 16" Wheels (optional)	A735-999-90	1
†	1-1/2" NPT Pipe Nipple	1696-043-00	2
(*)	Standard Hardware Item, Available Locally		
(†)	Not Shown		