

Please read and save this Repair Parts Manual. Read this manual and the General Operating Instructions carefully before attempting to assemble, install, operate or maintain the product described. Protect yourself and others by observing all safety information. The Safety Instructions are contained in the General Operating Instructions. Failure to comply with the safety instructions accompanying this product could result in personal injury and/or property damage! Retain instructions for future reference. AMT reserves the right to discontinue any model or change specifications at any time without incurring any obligation.

©2018 AMT Pump Company, A Subsidiary of The Gorman-Rupp Company, All Rights Reserved.

Periodic maintenance and inspection is required on all pumps to ensure proper operation. Unit must be clear of debris and sediment. Inspect for leaks and loose bolts. Failure to do so voids warranty.

Industrial Coolant Pumps



Refer to pump manual 1808-634-00 for General Operating and Safety Instructions.

DESCRIPTION

These coolant/recirculating pumps are heavy-duty industrial units designed for a variety of applications involving evaporating coolers, fountains, laboratories, bilge pumping, etc. Each pump is constructed using cast iron column and base parts, stainless steel impeller, shaft and hardware. All units are manual models; no controls are supplied. For use with nonflammable liquids, compatible with pump component materials.

SPECIFICATIONS

Liquid Temperature.....	40° to 200F (4° to 93C)
Maximum Liquid Viscosity.....	500 SSU
Specific Gravity (S.G) Maximum.....	1.0
Discharge Outlet:	
4421-95 thru 4431-95.....	1 1/4" NPT
4440-95 thru 4443-95.....	1 1/2" NPT
Pump Construction.....	Cast Iron
Impeller Material.....	Stainless Steel
Fasteners.....	Stainless Steel

OPERATION

- Liquid level should always be below opening located in top of column. Motor is NOT submersible.
- Activate unit. No controls are supplied with this unit. Dry running will not harm pump or motor.
- Familiarize yourself and others with all controls for this pump. Learn how to stop pump/motor quickly in an emergency.

MAINTENANCE

Make certain that the unit is disconnected from the power source before attempting to service or remove any component! Failure to do so could result in electrical shock.

PERFORMANCE CHART

Models 4430-95 and 4431-95

	GPM at Total Head in Feet					Shut-Off
	3'	6'	9'	12'	15'	
Water	48	46	42	38	32	21 ft.
500 SSU	40	38	34	30	25	21 ft.

Models 4421-95 and 4422-95

	GPM at Total Head in Feet					Shut-Off
	3'	6'	9'	12'	15'	
Water	46	43	36	30	20	17 ft.
500 SSU	26	23	19	15	8	17 ft.

Models 4440-95, 4442-95 and 4443-95

	GPM at Total Head in Feet								Shut-Off
	3'	6'	9'	12'	15'	18'	21'	24'	
Water	-	-	-	67	58	48	38	27	32 ft.
500 SSU	50	46	42	37	32	27	20	12	27 ft.

IMPELLER/MOTOR REPLACEMENT PROCEDURE

- Remove pump assembly from tank or reservoir.
- Remove volute (Ref. No. 14) by removing cap screws (Ref. No. 6), leaving volute cover (Ref. No. 9) attached to column (Ref. No. 3).
- Place a 5/32" allen wrench through slot in top of column and into one of the socket head screws of coupling (Ref. No. 2). Rotate impeller (Ref. No. 11) so allen wrench is against side of slot preventing shaft from rotating and remove acorn nut (Ref. No. 12) and impeller. Nut and impeller both have right hand thread.
- Remove allen wrench from slot and remove four cap screws (Ref. No. 5) holding motor to column.
- Remove motor (Ref. No. 1) with shaft (Ref. No. 10) and coupling assembly from column.
- Loosen socket head screws in coupling and remove coupling from motor shaft and pump shaft.
- To reassemble, place motor in a vertical position then slide coupling onto motor shaft until end of shaft is flush with split in center of coupling. Tighten two socket head screws holding coupling to motor shaft.
- Replace motor and coupling onto column and secure with four cap screws with split washers (Ref. No. 4).
- Thread impeller onto shaft and tighten.
- Replace acorn nut and tighten.
- Turn motor and column, with volute cover attached, upside down in a vertical position.
- Insert shaft assembly into column until there is a clearance between impeller and volute cover of 0.024/0.011 for 4430-95 thru 4422-95 and 0.159/0.146 for 4442-95 thru 4443-95 then tighten coupling.
- Using a new gasket (Ref. No. 13), reassemble volute to volute cover.
- Rotate impeller to make sure it does not strike volute cover or volute. If impeller strikes either volute cover or volute, go back to step 12 and adjust clearance.
- Return pump to service.

For Repair Parts contact dealer where pump was purchased.

Please provide following information:

- Model Number
- Serial Number (if any)
- Part description and number as shown in parts list

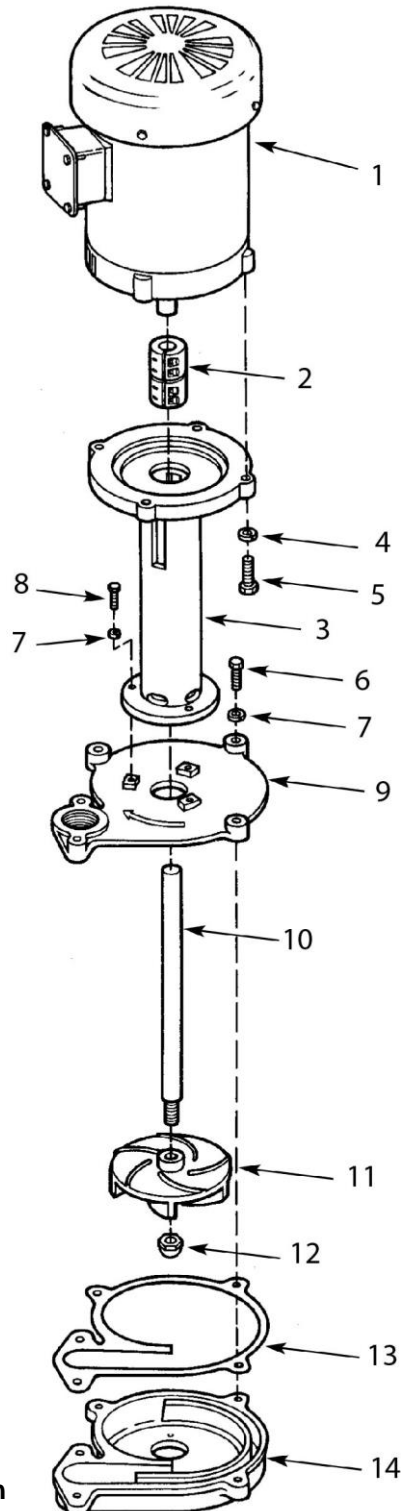

Figure 1 – Repair Parts Illustration

Repair Parts List

Ref. No.	Description	Part Number for Models:								Qty.
		4430-95	4431-95	4421-95	4422-95	4442-95	4440-95	4441-95	4443-95	
1	Motor	1626-M05-00	1626-021-00	1626-M05-00	1626-021-00	1626-006-00	1626-006-00	1626-022-00	1626-022-00	1
2	Coupling	4430-143-00	4430-143-00	4430-143-00	4430-143-00	4430-143-00	4430-143-00	4430-143-00	4430-143-00	1
3	Column	Incl. w/ Ref. 9	Incl. w/ Ref. 9	Incl. w/ Ref. 9	Incl. w/ Ref. 9	Incl. w/ Ref. 9	Incl. w/ Ref. 9	Incl. w/ Ref. 9	Incl. w/ Ref. 9	1
4	3/8" Split Lock Washer S.S.	1793-009-00	1793-009-00	1793-009-00	1793-009-00	1793-009-00	1793-009-00	1793-009-00	1793-009-00	4
5	3/8"-16 UNC x 11/4" Cap Screw S.S	1757-001-00	1757-001-00	1757-001-00	1757-001-00	1757-001-00	1757-001-00	1757-001-00	1757-001-00	4 or 7
6	1/4"-20 UNC x 1" Cap Screw S.S.	1718-003-00	1718-003-00	1718-003-00	1718-003-00	1718-003-00	1718-003-00	1718-003-00	1718-003-00	5 or 7
7	1/4" Split Lock Washer S.S.	1788-001-00	1788-001-00	1788-001-00	1788-001-00	1788-001-00	1788-001-00	1788-001-00	1788-001-00	8 or 10
8	1/4"-20 UNC x 1" Cap Screw S.S.	1718-003-00	1718-003-00	1718-003-00	1718-003-00	1718-003-00	1718-003-00	1718-003-00	1718-003-00	3
9	Volute/Column Kit (includes Ref. Nos. 5, 6, 7, and 8)	4430-020-95	4430-020-95	4430-021-95	4430-021-95	4440-021-95	4440-020-95	4440-020-95	4440-021-95	1
10	S.S. Shaft	4430-140-00	4430-140-00	4430-141-00	4430-141-00	4430-142-00	4430-140-00	4430-140-00	4430-142-00	1
11	Impeller	4430-012-01	4430-012-01	4421-012-01	4421-012-01	4440-012-01	4440-012-01	4440-012-01	4440-012-01	1
12	7/16"-20 UNF Acorn Nut S.S.	1784-001-00	1784-001-00	1784-001-00	1784-001-00	1784-001-00	1784-001-00	1784-001-00	1784-001-00	1
13	Gasket	4430-300-00	4430-300-00	4430-300-00	4430-300-00	4440-300-00	4440-300-00	4440-300-00	4440-300-00	1
14	Volute	4430-001-09	4430-001-09	4430-001-09	4430-001-09	4440-001-09	4440-001-09	4440-001-09	4440-001-09	1