

Please read and save this Repair Parts Manual. Read this manual and the General Operating Instructions carefully before attempting to assemble, install, operate or maintain the product described. Protect yourself and others by observing all safety information. The Safety Instructions are contained in the General Operating Instructions. Failure to comply with the safety instructions accompanying this product could result in personal injury and/or property damage! Retain instructions for future reference. AMT reserves the right to discontinue any model or change specifications at any time without incurring any obligation.

©2018 AMT Pump Company, A Subsidiary of The Gorman-Rupp Company, All Rights Reserved.

Periodic maintenance and inspection is required on all pumps to ensure proper operation. Unit must be clear of debris and sediment. Inspect for leaks and loose bolts. Failure to do so voids warranty.

3-Inch Trash Pump

Refer to form 1808-633-00 for General Operating and Safety Instructions.



DESCRIPTION

These trash pumps are high capacity, heavy duty, centrifugal, engine driven, self-priming (to 20 ft. lift) portable units. The pumps are equipped with a precision lapped mechanical seal to reduce leakage, carrying handle and a clog-resistant impeller capable of handling solids up to 1-1/2" diameter (up to 25% by volume). A 3" NPT suction strainer is included. Handles liquids from 40° to 180° F (4° to 82° C). For use with nonflammable liquids compatible with pump component materials.

NOTE: Electric-start models require a 12-volt, 32 amp hour battery (not included).

MAINTENANCE

⚠ WARNING

To prevent accidental starting, always remove the spark plug or disconnect and ground the spark plug wire before attempting to service or remove any component.

CLEANING

These units are designed so that for most cleanout or clogging problems it should not be necessary to remove hoses or piping. The suction area and impeller chambers can be reached by removing (2) threaded handles (Ref. No. 26), suction cleanout cover plate (Ref. No. 25) and gasket (Ref. No. 34).

NOTE: When replacing cleanout cover plate, carefully wipe clean all surfaces on which the gasket has contact. Also, make sure the gasket is in position.

MECHANICAL SEAL REPLACEMENT

Refer to figures 1 and 2.

NOTE: Always replace the seal seat (Ref. No. 11), seal cartridge (Ref. No. 12), and shaft sleeve (Ref. No. 3) to ensure proper mating of mechanical seal components!

1. Unthread cap screws (Ref. No. 18) to remove casing (Ref. No. 17) and casing seal (Ref. No.35) from adapter (Ref. No. 5).
2. Unthread screws (Ref. No. 13) and remove volute (Ref. No. 14) from adapter.
3. Unscrew impeller (Ref. No. 2) from the engine shaft. Remove the impeller shims (Ref. No. 4), shaft sleeve and seal cartridge from engine shaft. Use a rubber mallet or soft block of wood to loosen impeller. Turn counterclockwise.
4. Unthread cap screws (Ref. No. 8) and remove the adapter from the engine mounting face.
5. Push seal seat from the adapter recess with a screwdriver.
6. Clean the adapter recess before inserting a new seal seat.
7. Carefully wipe the polished surface of the new seal seat with a clean cloth.
8. Wet the rubber portion of the seal seat with a light coating of soapy water.
9. Press the new seal seat squarely into the cavity in the adapter. If the seal seat does not press squarely into the cavity, it can be adjusted in place by pushing on it with a piece of pipe. Always use a piece of cardboard between the pipe and the seal seat to avoid scratching the seal seat. (This is a lapped surface and must be handled very carefully).
10. After the seal seat is in place, ensure that it is clean and has not been marred.
11. Using a clean cloth, wipe the shaft and make certain that it is perfectly clean.

12. Secure the adapter on the engine mounting face.

NOTE: Tighten cap screws EVENLY to avoid cracking rabbet on engine mounting face.

13. Apply a light coating of soapy water to the inside rubber portion of seal cartridge and slide onto the shaft sleeve. Slip the shaft sleeve with seal cartridge onto the engine shaft.

IMPORTANT: Before installing new shaft sleeve, apply a bead of non-hardening, pliable sealant (such as Permatex® Form-A-Gasket® No. 2) to motor shaft shoulder.

14. Replace any impeller shim removed in disassembly.
 15. Screw the impeller back in place tightening until it is seated against shims and shaft sleeve.
 16. Remount volute with fasteners.
 17. Refer to section entitled SHIM ADJUSTMENT at this time if shaft sleeve or any other parts listed therein have been replaced.
 18. Inspect position of flapper valve assembly (Ref. No.15) to ensure proper movement and seating.
 19. Replace o-ring seal on volute rabbet.
- NOTE:** Always inspect o-ring seals. Replace when cracked or worn. Wet o-ring with soapy water for ease of assembly.
20. Remount casing.
 21. Remount any other parts and reconnect spark plug wire. Pump should now run with renewed original performance.

SHIM ADJUSTMENT

1. When installing a replacement impeller, engine, shaft sleeve, adapter or volute, it may be necessary to vary the number of impeller shims (Ref. No. 4) that will be required. This is easily done by adding one 0.010" shim more than was removed and reassembling pump as described in Mechanical Seal Replacement section.
2. Ensure that volute (Ref. No. 13) and adapter (Ref. No. 5) are fitted firmly (check fastener Ref. Nos. 8 & 14). Remove spark plug wire from engine and turn engine over by pulling the recoil starter. If engine does not run freely, disassemble pump and remove one shim.
3. Proper running clearance is 0.010".
4. Follow the above procedure until proper clearance is obtained. This will ensure maximum performance.

3-Inch Trash Pump

IMPELLER AND WEARPLATE REPLACEMENT

Impeller (Ref. No. 2), volute/wearplate (Ref. No. 5) and rear wearplate (Ref. No. 9) are subject to wear only by abrasive sand or sediment laden liquids. If badly worn, all these parts can be replaced easily and the pump thus restored to full efficiency.

NOTE: When the clearance between the impeller and the volute/wearplate exceeds 1/16" at the face of the impeller or 1/8" on the outside diameter of the impeller, it may be necessary to take corrective action. The increased clearance can cause lengthened priming and decreased capacity to your unit. If performance is satisfactory for your application, it is recommended that no corrective maintenance be performed regardless of what clearances on your unit may have developed. This is because increased clearances in themselves are not generally harmful to your pump. Normally, new pump clearances can be restored by simply shimming behind the impeller. (Add shim washers Ref. No. 4). If the impeller is badly worn, it is recommended that the impeller be replaced. This is usually all that is required since only on abrasive surfaces does the cast iron wearplate show deterioration. Occasionally a stone or hard object might get caught in the impeller and cause damage to the volute/cutwater. In these cases follow the instructions below for replacement and refer to Figure 1.

1. Disassemble pump for access as described in Mechanical Seal Replacement, steps 1 and 2.
 2. Replace parts as necessary.
- NOTE:** When replacing volute/wearplate, attach flapper valve assembly (Ref. No. 15) to the new volute with fastener (Ref. No. 16).
3. To replace rear wearplate (Ref. No. 9), remove fasteners (Ref. No. 10) after impeller has been removed.

NOTE: Before Installing new parts, clean all mating surfaces thoroughly.

SUCTION FLANGE REPLACEMENT

1. Unthread the four screws on the suction flange (Ref. No. 28).
2. Remove the old gasket.
3. Replace the gasket. Gasket must be installed between suction flange and casing for proper seal and priming.
4. Install new suction flange and thread the four bolts to the casing. Tighten the bolts in an alternating pattern to avoid pinching

DISCHARGE FLANGE REPLACEMENT

1. Unthread the four screws on the discharge flange (Ref. No. 30).
2. Remove the old gasket.
3. Replace the gasket. Gasket must be installed between discharge flange and casing for proper seal.
4. Install new discharge flange and thread the four bolts to the casing. Tighten the bolts in an alternating pattern to avoid pinching

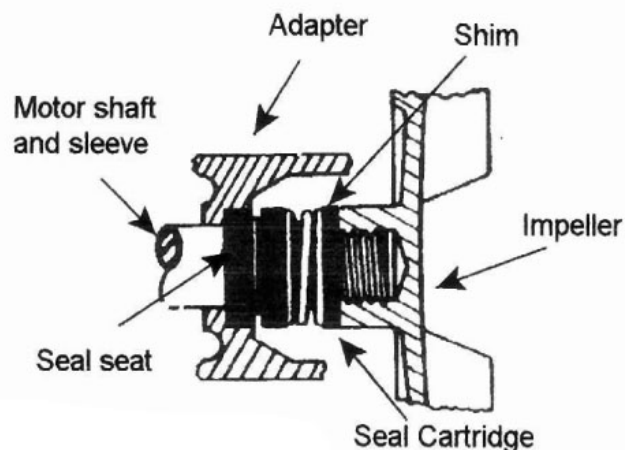

Figure 1 - Mechanical Seal Replacement

3-Inch Trash Pump

For Repair Parts contact dealer where pump was purchased.

Please provide following information:

-Model Number

-Serial Number (if any)

Part description and number as shown in parts list

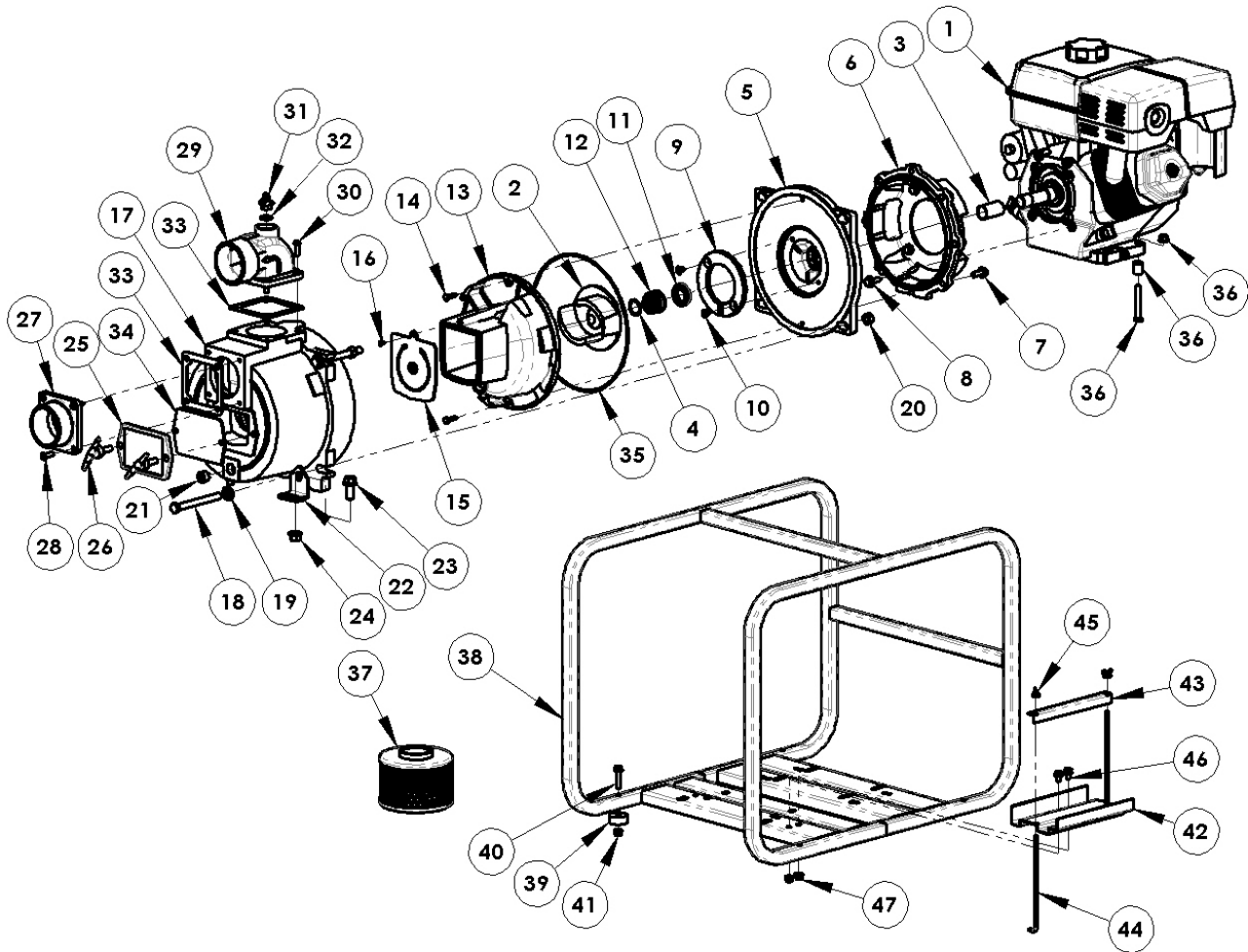

Figure 2 - Repair Parts Illustrations

Repair Parts List

Ref. No.	Description	Part Number for Models:			Qty.
		3941-96	3943-96	3944-96	
1	Engine	1639-024-00	1639-026-00	1639-028-00	1
2	Impeller Kit (Includes Ref. Nos. 2, 3 & 4)	3590-010-95	3590-010-95	3590-010-95	1
3	Shaft Sleeve	1555-143-00 & Incl. w/Ref 2	1555-143-00 & Incl. w/Ref 2	1555-143-00 & Incl. w/Ref 2	1
4	Impeller Shim Kit	1656-000-90 & Incl. w/Ref 2	1656-000-90 & Incl. w/Ref 2	1656-000-90 & Incl. w/Ref 2	1
5	Casing Cover Kit (Includes Ref. Nos. 5, 6, 7 & 8)	3993-020-96	3993-020-96	3993-020-96	1
6	Adapter	Incl. w/Ref 5	Incl. w/Ref 5	Incl. w/Ref 5	1
7	Hex Screw	Incl. w/Ref 5	Incl. w/Ref 5	Incl. w/Ref 5	6
9	Hex Screw	Incl. w/Ref 5	Incl. w/Ref 5	Incl. w/Ref 5	4
9	Wear Plate Kit (Includes Ref. Nos. 9 & 10)	2182-004-90	2182-004-90	2182-004-90	1
10	Flat Head Screw	Incl. w/Ref 9	Incl. w/Ref 9	Incl. w/Ref 9	2
11,12	Seal Assembly-SiC/SiC/Viton	1640-167-90	1640-167-90	1640-167-90	1
13	Volute Kit (Includes Ref. Nos. 13 & 14)	3945-150-90	3945-150-90	3945-150-90	1
14	Hex Screw	Incl. w/Ref 13	Incl. w/Ref 13	Incl. w/Ref 13	2
15	Check Valve Kit-Buna-N (standard)	3590-070-90	3590-070-90	3590-070-90	1
	Check Valve Kit-Viton (optional)	3590-071-90	3590-071-90	3590-071-90	1
	(Includes Ref. Nos. 15 & 16)				
16	Flat Head Screw	Incl. w/Ref 16	Incl. w/Ref 16	Incl. w/Ref 16	2
17	Casing Kit (Includes Ref. Nos. 17, 18, 19, 20 & 21)	3941-004-96	3941-004-96	3941-004-96	1
18	1/2-13x5" Hex Bolt	Incl. w/Ref 17	Incl. w/Ref 17	Incl. w/Ref 17	4
19	1/2 Flat Washer	Incl. w/Ref 17	Incl. w/Ref 17	Incl. w/Ref 17	8
20	1/2-13 Hex Nut	Incl. w/Ref 17	Incl. w/Ref 17	Incl. w/Ref 17	4
21	1/2" NPT Plug	Incl. w/Ref 17	Incl. w/Ref 17	Incl. w/Ref 17	1
22	Casing Foot Kit (Includes Ref. Nos. 22, 23 & 24)	3993-109-90	3993-109-90	3993-109-90	1
23	Hex Bolt	Incl. w/Ref 22	Incl. w/Ref 22	Incl. w/Ref 22	2
24	Hex Nut	Incl. w/Ref 22	Incl. w/Ref 22	Incl. w/Ref 22	2
25	Clean Out Cover Kit (Includes Ref. Nos. 25 & 26)	2115-002-95	2115-002-95	2115-002-95	1
26	Handle Stud	Incl. w/Ref 25	Incl. w/Ref 25	Incl. w/Ref 25	2
27	Suction Flange Kit (Includes Ref. Nos. 27 & 28)	3S5X-050-95	3S5X-050-95	3S5X-050-95	1
28	Hex Screw	Incl. w/Ref 27	Incl. w/Ref 27	Incl. w/Ref 27	4
29	Discharge Manifold Kit (Includes Ref. Nos. 29 & 30)	3S5X-080-95	3S5X-080-95	3S5X-080-95	1
30	Hex Screw	Incl. w/Ref 29	Incl. w/Ref 29	Incl. w/Ref 29	4
31	Fill Plug Kit-Buna-N oring (standard)	3SXB-170-90	3SXB-170-90	3SXB-170-90	1
	Fill Plug Kit-Viton oring (optional)	3SXV-170-90	3SXV-170-90	3SXV-170-90	1
	(Includes Ref. Nos. 31 & 32)				
32	#117 O-ring	Incl. w/Ref 31	Incl. w/Ref 31	Incl. w/Ref 31	1

Repair Parts List - CONTINUED

Ref.		Part Number for Models:			Qty.
No.	Description	3941-96	3943-96	3944-96	
KIT	Gasket Kit-Buna-N (standard)	3941-302-90	3941-302-90	3941-302-90	1
	Gasket Kit-Viton (optional) (includes Ref. Nos. 33, 34 & 35)	3941-302-91	3941-302-91	3941-302-91	1
33	Flange Gasket	Incl. w/Ref KIT	Incl. w/Ref KIT	Incl. w/Ref KIT	2
34	Clean Out Cover Gasket	Incl. w/Ref KIT	Incl. w/Ref KIT	Incl. w/Ref KIT	1
35	#276 O-ring	Incl. w/Ref KIT	Incl. w/Ref KIT	Incl. w/Ref KIT	1
36	Mount hardware kit (includes raising blocks, bolts, nuts & washers)	1695-105-91	3993-107-90	3993-107-90	1
37	Suction Strainer	C520-90	C520-90	C520-90	1
38	Roll Frame	C401-100-00	C401-100-00	C401-100-00	1
39	Rubber Foot Kit (includes Ref. Nos. 39, 40 and 41)	C400-100-91	C400-100-91	C400-100-91	1
40	Hex Bolt	Incl. w/Ref 39	Incl. w/Ref 39	Incl. w/Ref 39	4
41	Hex Nut	Incl. w/Ref 39	Incl. w/Ref 39	Incl. w/Ref 39	4
42	Battery Tray Kit (includes Ref. Nos. 42, 43, 44, 45, 46 & 47)	N/A	N/A	1696-101-91	1
43	J-Bolt	N/A	N/A	Incl. w/Ref 42	2
44	Battery Hold Down	N/A	N/A	Incl. w/Ref 42	1
45	Wing Nut	N/A	N/A	Incl. w/Ref 42	2
46	Hex Bolt	N/A	N/A	Incl. w/Ref 42	2
47	Hex Nut	N/A	N/A	Incl. w/Ref 42	2
‡	Battery Cable Assembly (12" Black)	N/A	N/A	3102-104-90	1
‡	Battery Cable Assembly (30" Red)	N/A	N/A	3102-106-90	1
(‡)	Not Shown				