

Please read and save this Repair Parts Manual. Read this manual and the General Operating Instructions carefully before attempting to assemble, install, operate or maintain the product described. Protect yourself and others by observing all safety information. The Safety Instructions are contained in the General Operating Instructions. Failure to comply with the safety instructions accompanying this product could result in personal injury and/or property damage! Retain instructions for future reference. AMT reserves the right to discontinue any model or change specifications at any time without incurring any obligation.

©2017 AMT Pump Company, A Subsidiary of The Gorman-Rupp Company, All Rights Reserved.

Periodic maintenance and inspection is required on all pumps to ensure proper operation. Unit must be clear of debris and sediment. Inspect for leaks and loose bolts. Failure to do so voids warranty.

# Sewage/Trash Pumps

Refer to pump manual 1808-634-00 for General Operating and Safety Instructions.



## DESCRIPTION

This sewage/trash pump is a heavy duty, centrifugal, motor driven, self-priming (to 20 ft. lift) unit, after initially filling casing with liquid. Pump is equipped with a silicon carbide mechanical seal, cast iron wear surfaces and a stainless steel clog-resistant impeller. Units are used to handle water containing sewage, stones, sticks, mud and other solids: maximum diameter ½ the discharge NPT size. Handle liquids from 40° to 180° F (4° to 82° C) for use with nonflammable fluids compatible with pump component materials. All units come with built-in suction check valve to aid priming efficiency and easily removable casing/cleanout cover and volute for quick debris clean out. A NPT threaded seal wash port is provided on Models 393A-95, 393B-95, 394G-95, 394H-95, 394J-95, 394K-95 and 399D-95. Units are powered by totally enclosed fan cooled (TEFC) motors, single or three phase power. Motor includes stainless steel shaft or stainless steel shaft sleeve.

## ▲ WARNING

**Pumps must be operated in specific ranges as noted on respective curves on page 4 (Figure 3). Failure to adhere to curve will result in damage and cavitation to pump thus voiding warranty.**

## UNPACKING

Refer to Repair Parts Illustration and Repair Parts List to aid in identifying parts. Unpack and separate all pump components from container making sure all parts are accounted for.

Package should contain:

1. Pump and motor completely assembled.
2. Suction strainer.
3. Specifications Information & Repair Parts Manual.
4. General Operating Instructions & Maintenance Manual.

## MAINTENANCE

**Note:** For information pertaining to the motor and motor parts, consult the motor manual or contact the nearest authorized service representative or the manufacturer.

## ▲ WARNING

**Make certain that the unit is disconnected from the power source before attempting to service or remove any component.**

## MECHANICAL SEAL REPLACEMENT

Should the mechanical seal, which consists of a seal seat (stationary) and seal head (rotating), require replacement, proceed as follows and refer to Repair Parts illustration that corresponds to your pump model (316A/B = Figure 4, 393A/B = Figure 5, 394G/H = Figure 6, 394J/K & 399D = Figure 7). The seal should be replaced if the adapter or impeller is replaced. If the pump is equipped with a shaft sleeve (JM motor) it may be easier to replace the sleeve with the rotating seal head.

**NOTE:** Always replace the seal seat and head as a unit, never replace the seal seat or seal head individually.

### 316:

1. Remove four bolts (Ref. No. 9). Pull casing (Ref. No. 1) from adapter (Ref. No. 8).
2. Remove casing O-ring (Ref. No. 7). Remove screw (Ref. No. 11). Pull volute (Ref. No. 2) from adapter.
3. Remove impeller lock nut (Ref. No. 18). Unscrew impeller (Ref. No. 3) from motor shaft (Ref. No. 17). Use a rubber mallet or soft block of wood to loosen impeller. Turn it counterclockwise.
4. Remove the impeller shim(s) (Ref. No. 4).
5. Remove the seal head (Ref. No. 5) from motor shaft.
6. Remove four screws (Ref. No. 13). Pull adapter from motor.
7. Push seal seat (Ref. No. 6) from adapter. Clean seal seat bore in adapter.
8. Check motor shaft for damage. Motor shaft must be smooth and free from scratches or score marks. Clean shaft of any debris or remnants of old seal head.

### 393:

1. Remove four bolts (Ref. No. 9). Pull casing (Ref. No. 1) from adapter (Ref. No. 8).
2. Remove casing O-ring (Ref. No. 7). Remove two screws (Ref. No. 11). Pull volute (Ref. No. 2) from adapter.
3. Using a hex key remove impeller screw (Ref. No. 18) and O-ring (Ref. No. 25). Slide impeller (Ref. No. 3) from motor shaft (Ref. No. 17).
4. Remove the impeller shim(s) (Ref. No. 4) and impeller drive key (Ref. No. 21)
5. Slide the seal head (Ref. No. 5) off the shaft sleeve (Ref. No. 19).

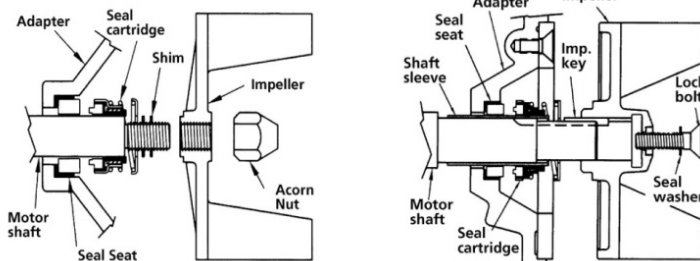

Figure 1 & 2 - Mechanical Seal Replacement

# Sewage/Trash Pumps

6. Remove four screws (Ref. No. 13). Pull adapter from motor.
7. Push seal seat (Ref. No. 6) from adapter. Clean seal seat bore in adapter.
8. Remove the shaft sleeve from the motor shaft if the sleeve is damaged or scored. The shaft sleeve is fixed to the motor shaft with pliable sealant, heat may be required to breakdown the sealant. If the shaft sleeve is smooth it does not need to be replaced. Clean shaft sleeve of any debris or remnants of the old seal head. Replace damaged shaft sleeve with new replacement. **IMPORTANT:** Before installing a new shaft sleeve apply a bead of non-hardening pliable sealant (such as Permatex® Form-A-Gasket® No. 2) to motor shaft shoulder.

## 394 & 399:

1. Remove four bolts (Ref. No. 19). Pull casing assembly (Ref. No. 16) from adapter (Ref. No. 2).
2. Remove casing O-ring (Ref No. 33). Remove two screws (Ref. No. 15). Pull volute (Ref. No. 14) from adapter.
3. Using a hex key remove impeller screw (Ref. No. 11) and O-ring Ref. No. 34). Slide impeller (Ref. No. 10) from motor shaft.
4. Remove the impeller shim(s) (Ref. No. 13) and impeller drive key (Ref. No. 12).
5. Slide the seal head (Ref. No. 9) off the shaft sleeve (Ref. No. 5).
6. Remove four screws (Ref. No. 3). Pull adapter from motor.
7. Push seal seat (Ref. No. 8) from adapter. Clean seal seat bore in adapter.
8. Remove the shaft sleeve from the motor shaft if the sleeve is damaged or scored. The shaft sleeve is fixed to the motor shaft with pliable sealant, heat may be required to breakdown the sealant. If the shaft sleeve is smooth it does not need to be replaced. Clean shaft sleeve of any debris or remnants of the old seal head. Replace damaged shaft sleeve with new replacement. **IMPORTANT:** Before installing a new shaft sleeve apply a bead of non-hardening pliable sealant (such as Permatex® Form-A-Gasket® No. 2) to motor shaft shoulder.

**IMPORTANT:** Care should be taken to ensure that the same number of impeller shims are replaced behind the impeller as were removed. The impeller shims are located directly behind the impeller.

## **CAUTION**

**The precision lapped faces on the mechanical seal are easily damaged. Handle your replacement seal carefully.**

9. Carefully wipe the polished surface of the new seal seat with a clean cloth.
10. Wet rubber portion of the seal seat with a light coating of soapy water.
11. While wearing clean gloves or using a clean rag, press seal seat squarely into adapter recess. Avoid scratching the polished surface. If seal seat will not position properly, place a cardboard washer over the polished surface and use a piece of pipe to press in, firmly but gently.
12. After seal seat is in place, dispose of cardboard washer. Check that the seal seat is clean and has not been marred.
13. Using a clean cloth, wipe the shaft and make certain that it is perfectly clean.
14. Secure the adapter on the motor mounting surface with fasteners.
15. Wet the rubber portion of the new seal head with a light coating of soapy water. Slide seal head over motor shaft (316) or shaft sleeve (393, 394, & 399) until rotating ring of seal head meets seal seat face.
16. Reinstall any impeller shims that have been removed. (See "Shim Adjustment" section).

**NOTE:** Always inspect O-ring seals. Replace when cracked or worn. Wet O-ring with soapy water for ease of installation.

17. 316; screw impeller back in place. Tighten until it is seated against shims and shaft shoulder. 393, 394 & 399; Install impeller drive key into motor shaft keyway. Align impeller keyway with drive key, slide impeller onto motor shaft. Replace impeller O-ring and install impeller screw. Tighten screw until impeller is seated against shims and shaft sleeve.
18. Remount volute with screw(s).
19. Refer to section entitled "Shim Adjustment" at this time if shaft sleeve or any parts, other than shaft seal, have been replaced.
20. 316 & 393; Inspect position of flapper valve (Ref. No. 16) to ensure proper movement and sealing. 394 & 399; Inspect position of volute gasket (Ref. No. 35) to ensure proper sealing of volute to casing.
21. Replace casing O-ring seal on volute outside flange diameter.
22. Remount casing.
23. Remount any other parts.

## SHIM ADJUSTMENT

When installing a replacement impeller, motor, shaft sleeve, adapter or volute, it may be necessary to adjust the number of impeller shims to ensure proper running clearance between impeller and the volute wear surface. Proceed as follows:

**NOTE:** Proper running clearance is 0.020".

1. For impeller replacement, add one (1) shim in addition to those removed originally.
2. For motor replacement, add one (1) shim in addition to the shims removed during disassembly.
3. Reassemble the pump as described in steps 16, 17, and 18. (See "MECHANICAL SEAL REPLACEMENT" section).

**IMPORTANT:** Check the shaft to make sure it is turning freely (rotate the impeller by the impeller lock bolt with an Allen wrench or by the acorn nut with a socket wrench). If it turns freely, check to ensure that the volute and adapter are fitted metal-to-metal where they meet on the outside. If they are not metal-to-metal, tighten fasteners and recheck the shaft for free turning. Tighten carefully, turning the shaft while tightening so that the motor bearings are not damaged in the event that too many shims were installed. If shaft seizes before fasteners are completely tight, disassemble the pump and remove one (1) shim and repeat reassembly.

**NOTE:** When adding or removing shims, it is best to proceed with a 0.010" increment each time. If motor shaft does not turn freely, add shims until it does strike, then remove a 0.010" shim. This will ensure maximum performance.

## IMPELLER, WEARPLATE, AND VOLUTE REPLACEMENT

316: Impeller (Ref. No. 3) and volute (Ref. No. 2), 393: Impeller (Ref. No. 3), volute (Ref. No. 2), and wear plate (Ref. No. 23), 394 & 399: Impeller (Ref. No. 10), volute (Ref. No. 14), and wear plate (Ref. No. 6) are subject to wear only by abrasive sand or sediment laden liquids. If badly worn, all these parts can

# Sewage/Trash Pumps

---

be replaced easily and the pump thus restored to full efficiency.

**NOTE:** When the clearance between the impeller and the volute exceeds 1/16" at the face of the impeller or 1/8" on the outside diameter of the impeller, it may be necessary to take corrective action. The increased clearance can cause lengthened priming times and reduce pumping capacity. If both the priming and capacity of your unit are satisfactory for your application, it is recommended that no corrective maintenance be performed regardless of what clearances on your unit may have developed, since the increased clearances in themselves are not generally harmful to your pump.

Normally, new pump clearances can be restored by simply shimming behind the impeller. (Add impeller shims). If the impeller is badly worn, it is recommended that the impeller be replaced. This is usually all that is required since only on unusually abrasive service does the cast iron wear plate and volute show deterioration. Occasionally a stone or hard object might get caught in the impeller and cause damage to the volute. In these cases, follow the instructions below for replacement and refer to the associated Repair Parts Illustration.

1. Disassemble pump for access as described in MECHANICAL SEAL REPLACEMENT, steps 1, 2, & 3.
2. Replace parts as necessary.

**NOTE:** When replacing volute attach check valve (316 & 393: Ref. No. 16) or volute gasket (394 & 399: Ref. No. 35) to new volute.

**NOTE:** Before installing new parts, clean all mating surfaces thoroughly.

## CLEANING

394 & 399 pumps are equipped with a removable cleanout cover (Ref. No. 28). To access impeller and suction chamber remove two handles (Ref. No. 29) pull the cleanout cover and gasket (Ref. No. 31) from the casing. Clean out any debris to unclog suction.

**NOTE:** When replacing cleanout cover plate, carefully wipe clean all surfaces on which the gasket has contact. Also, make sure the gasket is in position.

All pumps can be cleaned or unclogged by removing the casing and volute. Refer to MECHANICAL SEAL REPLACEMENT, steps 1 & 2.

## FLAPPER VALVE CLEANING

If debris clogging the flapper valve becomes a constant problem, the flapper area can be cut from the perimeter gasket area and removed from the pump. It is important that the perimeter of the flapper valve remains to seal the inlet area of the casing/volute from the discharge area.

**NOTE:** Priming efficiency will be reduced if flapper portion is removed.

**NOTE:** Do not remove entire flapper valve. Perimeter of valve must remain; remove only the flapper area. The pump will not prime and performance will be affected if entire flapper valve is removed.

# Sewage/Trash Pumps

**For Repair Parts contact dealer where pump was purchased.**

*Please provide following information:*

*-Model Number*

*-Serial Number (if any)*

*Part description and number as shown in parts list*

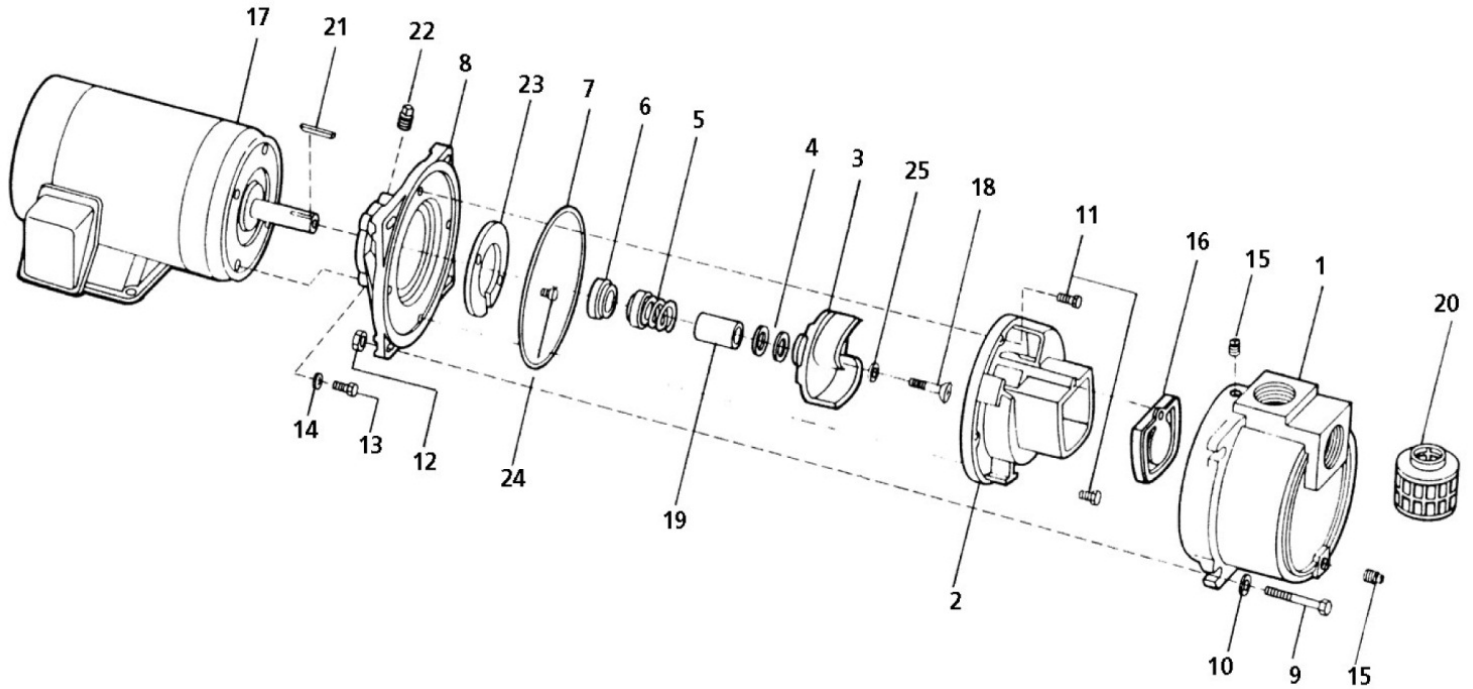

Figure 5 - Repair Parts Illustrations

**Repair Parts List**

Ref No.	Description	Part Number for Models		Qty
		393A-95	393B-95	
1	Casing Kit (Includes Ref. Nos. 1, 9, 10, 12 & 15)	3540-002-95	3540-002-95	1
2	Volute Kit (Includes Ref. Nos. 2 & 11)	393A-150-95	393A-150-95	1
3	Impeller Kit (Includes Ref. Nos. 3, 4, 18 & 21)	3935-011-98	3935-011-98	1
4	Impeller Shim Set	1664-000-90 & Incl. w/Ref. 3	1664-000-90 & Incl. w/Ref. 3	1
5 & 6	Seal Assembly – Viton and Silicon Carbide	1640-167-90	1640-167-90	1
7	O-Ring – Buna-N	Incl. w/Ref. 26	Incl. w/Ref. 26	1
8	Adapter Kit (Includes Ref. Nos. 8, 13, 14, 19 & 22)	3655-030-90	3655-030-90	1
9	Hex Head Bolt	Incl. w/Ref. 1	Incl. w/Ref. 1	4
10	Flat Washer	Incl. w/Ref. 1	Incl. w/Ref. 1	4
11	Machine Screw, SS	Incl. w/Ref. 2	Incl. w/Ref. 2	2
12	Hex Nut	Incl. w/Ref. 1	Incl. w/Ref. 1	4
13	Hex Head Cap Screw	Incl. w/Ref. 8	Incl. w/Ref. 8	4
14	Lock Washer	Incl. w/Ref. 8	Incl. w/Ref. 8	4
15	½" NPT Pipe Plug	Incl. w/Ref. 1	Incl. w/Ref. 1	2
16	Flapper Valve Assembly – Buna-N	Incl. w/Ref. 26	Incl. w/Ref. 26	1
17	Motor	1627-352-00	1626-078-00	1
18	Impeller Screw	Incl. w/Ref. 3	Incl. w/Ref. 3	1
19	Shaft Sleeve	1555-142-00 & Incl. w/Ref. 8	1555-142-00 & Incl. w/Ref. 8	1
20	Suction Strainer	1679-001-00	1679-001-00	1
21	Impeller Key	Incl. w/Ref. 3	Incl. w/Ref. 3	1
22	1/8" Pipe Plug	Incl. w/Ref. 8	Incl. w/Ref. 8	1
23	Wear Plate Kit (Includes Ref. Nos. 23 & 24)	393A-060-95	393A-060-95	1
24	Flat Head Machine Screw	Incl. w/Ref. 23	Incl. w/Ref. 23	2
25	O-Ring – Buna-N	Incl. w/Ref. 26	Incl. w/Ref. 26	1
26	Gasket Kit – Buna-N (Includes Ref. Nos. 7, 16, & 25)	393A-300-90	393A-300-90	1