

Please read and save this Repair Parts Manual. Read this manual and the General Operating Instructions carefully before attempting to assemble, install, operate or maintain the product described. Protect yourself and others by observing all safety information. The Safety Instructions are contained in the General Operating Instructions. Failure to comply with the safety instructions accompanying this product could result in personal injury and/or property damage! Retain instructions for future reference. AMT reserves the right to discontinue any model or change specifications at any time without incurring any obligation.

©2015 AMT Pump Company, A Subsidiary of The Gorman-Rupp Company, All Rights Reserved.

Periodic maintenance and inspection is required on all pumps to ensure proper operation. Unit must be clear of debris and sediment. Inspect for leaks and loose bolts. Failure to do so voids warranty.

Bronze Centrifugal Pump

Refer to pump manual 1808-634-00 for General Operating and Safety Instructions.



DESCRIPTION

These bronze centrifugal pumps are designed for medium volume liquid handling compatible with all pump component materials. Handles liquids from 40° to 180° F (4° to 82° C). For use with nonflammable, non-abrasive liquids compatible with pump component materials.

READ AND FOLLOW ALL INSTRUCTIONS

⚠ WARNING

To reduce the risk of injury, installation should be done by a qualified electrician.

IMPORTANT SAFETY INSTRUCTIONS

Save these instructions

When installing and using this electrical equipment, basic safety precautions should always be followed:

For specific safety precautions for installation and electrical connection information and to reduce the potential for fire, electric shock, or injury, read and follow all information and instructions contained in the form 1808-634-00, Electric Motor Driven Pumps Operating Instructions.

INSTALLATION

When installing this pump in a "Permanent" fixed-bolted down location install one each of the four rubbers washers under each slot in the motor adapter (Ref #) foot. (Note: The washer come with the pump attached to the pump handle with a cable). This will minimize vibration and provide a positive flat surface for the pump foot.

MAINTENANCE

⚠ WARNING

Make certain that unit is disconnected from power source before attempting to service or remove any components!

MECHANICAL SEAL REPLACEMENT

Refer to Figures 1 and 2

IMPORTANT: Always replace seal seat (Ref. No. 9) and seal head (Ref. No. 10) to ensure proper mating of mechanical seal components.

1. Unthread fasteners (Ref. No. 5) and remove casing (Ref. No. 13) and casing seal (Ref. No. 8)
2. Unscrew impeller (Ref. No. 12) from motor shaft. Remove shims (Ref. No. 11) and retain for reassembly.

NOTE: Some motors use an open end 7/16" wrench across flats on rear of motor shaft (remove bearing cap for access) to prevent shaft from turning. Other motor shafts have a screwdriver slot instead of flats.

3. Slide old seal head from motor shaft.
4. Unthread fasteners (Ref. No. 6) and remove assembled adapter (Ref. No. 4) and casing cover (Ref. No. 7) from motor mounting face.
5. Pry seal seat from rear of casing cover with a screwdriver.
6. Clean casing cover seal seat recess before inserting new seal parts.
7. Wet rubber portion of new seal seat with light coating of soapy water. Press seal seat squarely into adapter recess. Avoid scratching polished surface.

NOTE: Handle all seal parts with extreme care and attention to keeping them clean. Do not touch polished faces with your hands. Do not put lubricants of any kind on seal faces; this can cause seal to leak.

8. Inspect polished face of seal seat and polished face of seal head to ensure they are clean and not marred.
9. Using a clean cloth, wipe shaft and make certain that it is perfectly clean.
10. Slide assembled adapter and casing onto motor mounting face. Attached with fasteners.

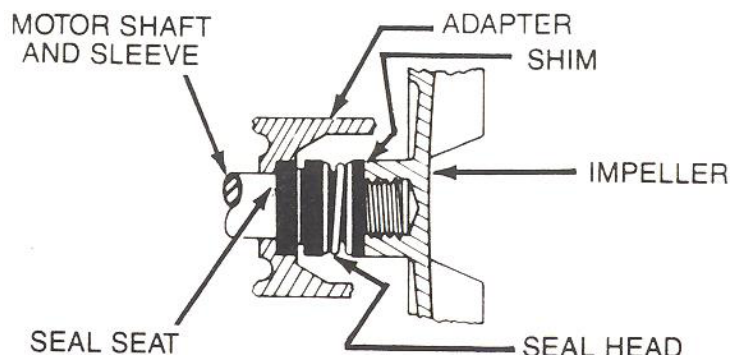

Figure 1 - Mechanical Seal Replacement

Bronze Centrifugal Pump

11. Wet inside rubber portion of new seal head with a light coating of soapy water. Slide head onto motor shaft.

IMPORTANT: Reinstall any shims or spacers, which may have been removed onto motor shaft before installing impeller.

12. Screw impeller back in place, tightening until it is against shaft shoulder.
13. Replace casing seal and casing. Attach with fasteners.

IMPORTANT: Always inspect casing seal when disassembled. Use a light oil or grease for ease of installation.

SHIM ADJUSTMENT

When installing a replacement impeller (Ref. No. 12), motor (Ref. No. 1), casing (Ref. No. 13), casing cover (Ref. No. 7) or adapter (Ref. No. 4) it may be necessary to vary number of shims (Ref. No. 11) to ensure proper running clearance between impeller and casing. Proceed as follows:

NOTE: A proper running clearance is less than 0.016".

1. For component replacement other than motor, add one (0.10") shim in addition to those removed originally.
2. For motor replacement, add two (0.10") shims in addition to shims removed during disassembly.
3. Disassemble and reassemble pump as described for component being replaced in applicable steps under MECHINCAL SEAL REPLACEMENT.

IMPORTANT: Be sure that casing is snugly in place and check shaft to make sure it is turning freely (use screwdriver or 7/16" open end wrench on end of motor shaft to turn). If it turns freely, check to ensure that casing cover and casing are fitted "metal to metal" and adaptor and motor are fitted "metal to metal" where they meet on outside. If they are not, tighten fasteners (Ref. Nos. 5 and 6) and recheck shaft for free turning. Tighten carefully, turning shaft while tightening so that motor bearings are not damaged in the event that too many shims were installed. If shaft seizes before fasteners are completely tight, disassemble pump and remove one shim and repeat reassembly.

Bronze Centrifugal Pump

For Repair Parts contact dealer where pump was purchased.

Please provide following information:

-Model Number

-Serial Number (if any)

Part description and number as shown in parts list

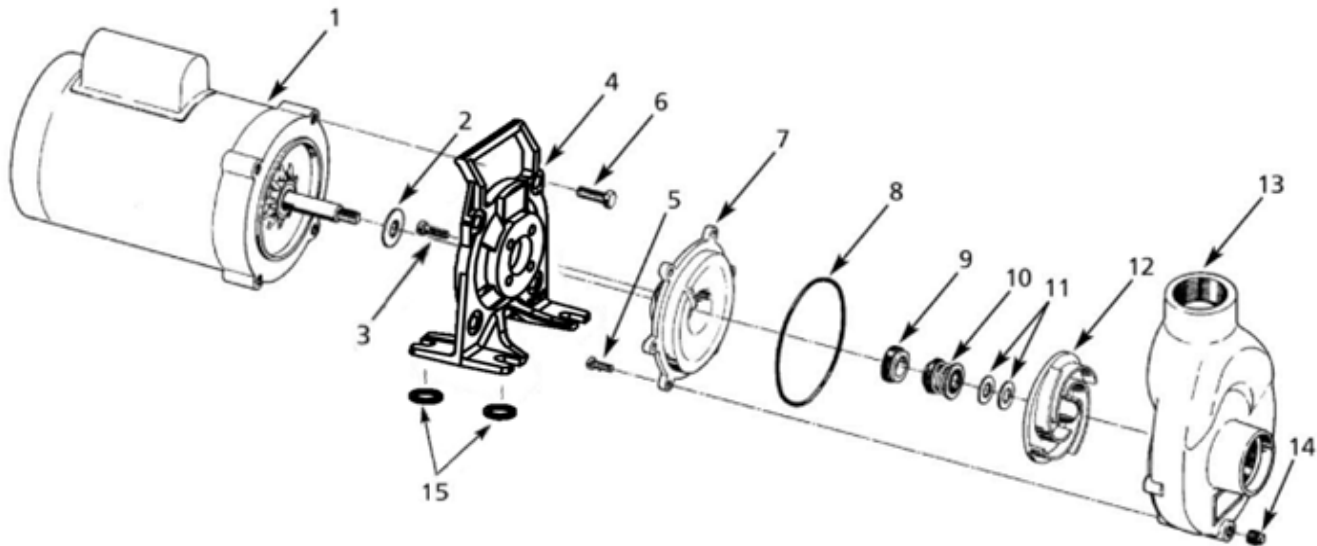

Figure 2 - Repair Parts Illustrations

Repair Parts List

Ref No.	Description	Part Number for Models					Qty
		388F-97	388G-97	388H-97	388J-97	388K-97	
1	Motor	1626-301-00	1626-302-00	1626-303-00	1626-304-00	1626-305-00	1
2	Slinger Washer (not required)	*	*	*	*	*	1
3	Fastener	*	*	*	*	*	4
4	Adapter	4294-030-09	4294-030-09	4294-030-09	4294-030-09	4294-030-09	1
5	Fastener	Incl. w/Ref 13	Incl. w/Ref 13	Incl. w/Ref 13	Incl. w/Ref 13	Incl. w/Ref 13	6
6	Fastener	*	*	*	*	*	4
7	Casing Cover	2104-003-01	2104-003-01	2104-003-01	2104-003-01	2104-003-01	1
8	Casing Seal - Buna-N (standard)	2104-004-00	2104-004-00	2104-004-00	2104-004-00	2104-004-00	1
	Casing Seal - Viton (optional)	2105-023-00	2105-023-00	2105-023-00	2105-023-00	2105-023-00	1
9 & 10	Shaft Seal Assembly - Buna-N (standard)	1640-161-90	1640-161-90	1640-161-90	1640-161-90	1640-161-90	1
	Shaft Seal Assembly - Viton (optional)	1640-161-91	1640-161-91	1640-161-91	1640-161-91	1640-161-91	1
11	Impeller Shim Package	1657-000-90	1657-000-90	1657-000-90	1657-000-90	1657-000-90	1
12	Impeller Kit	3880-010-97	3880-011-97	3880-012-98	3880-013-98	3880-014-97	1
	(includes Ref. Nos. 11 and 12)						
13	Casing Kit	3880-003-97	3880-003-97	3880-003-97	3880-003-97	3880-003-97	1
	(includes Ref. Nos. 5, 13 and 14)						
14	Pipe Plug	Incl. w/Ref 13	Incl. w/Ref 13	Incl. w/Ref 13	Incl. w/Ref 13	Incl. w/Ref 13	1
15	Rubber Washer 1" od x 3/4" id x 1/8" Thick	*	*	*	*	*	4

(*) Standard hardware item, available locally.