

Please read and save this Repair Parts Manual. Read this manual and the General Operating Instructions carefully before attempting to assemble, install, operate or maintain the product described. Protect yourself and others by observing all safety information. The Safety Instructions are contained in the General Operating Instructions. Failure to comply with the safety instructions accompanying this product could result in personal injury and/or property damage! Retain instructions for future reference. AMT reserves the right to discontinue any model or change specifications at any time without incurring any obligation.

©2016 AMT Pump Company, A Subsidiary of The Gorman-Rupp Company, All Rights Reserved.

Periodic maintenance and inspection is required on all pumps to ensure proper operation. Unit must be clear of debris and sediment. Inspect for leaks and loose bolts. Failure to do so voids warranty.

Small Straight Centrifugal Pumps

Cast Iron, Bronze and Stainless Steel Models



Refer to pump manual 1808-634-00 for General Operating and Safety Instructions.

DESCRIPTION

These pumps are non-self-priming (gravity feed) units designed to handle liquid transfer, heating and cooling applications, where no suction lift is required. All models feature semi-open, clog-resistant impellers and continuous duty, 3450 RPM, 56J frame motors. Discharge port can be rotated in 90° increments to accommodate specific applications. Casing working pressure to 75 psi (517 kPa). These are manual units, no controls are supplied. For use with nonflammable, nonabrasive liquids compatible with pump component materials.

CAST IRON UNITS

Pump construction is Investment Cast Iron casing and adapter. Cast 300 Series Stainless Steel impeller. Buna N mechanical shaft seal with carbon and ceramic wear faces. O-ring casing seal. Handles liquids from 40° to 180° F (4° to 82° C).

BRONZE UNITS

Pump construction is Investment Cast Bronze casing and adapter. Cast 300 Series Stainless Steel impeller. Viton® mechanical shaft seal with carbon and ceramic wear faces. O-ring casing seal. Handles liquids from 40° to 200° F (4° to 93° C).

STAINLESS STEEL UNITS

Pump construction is Investment Cast 300 Series Stainless Steel casing, adapter and impeller. Viton® mechanical shaft seal with carbon and ceramic wear faces. O-ring casing seal. Handles liquids from 40° to 200° F (4° to 93° C).

MAINTENANCE

⚠ WARNING

Make certain that unit is disconnected from power source before attempting to service or remove any components!

MECHANICAL SEAL REPLACEMENT:

Refer to Figures 1, 2, & 3.

IMPORTANT: Always replace both seal seat (Ref. No. 5) and seal head (Ref. No. 6) to ensure proper mating of components! Also, impeller seal (Ref. No. 9) should be replaced anytime impeller fastener (Ref. No. 10) has been removed.

1. Remove fasteners (Ref. No. 13) connecting casing (Ref. No. 12) to adapter (Ref. No. 4).
2. Remove casing.

⚠ CAUTION

Care should be taken not to "pinch" or "shave" casing seal (Ref. No. 11) between adapter and casing.

3. Use a box and/or socket wrench to remove impeller fastener. Remove impeller seal and impeller (Ref. No. 8).

IMPORTANT: Care should be taken to ensure that the same number and thickness of shim washers (Ref. No. 7) are replaced behind impeller that were removed. Shim washers are located directly behind impeller and become loose as impeller is removed.

4. Seal head can now be pulled from shaft.
5. Pry seal seat from adapter (Ref. No. 4).

⚠ CAUTION

The precision lapped faces on mechanical seal are easily damaged. Handle your replacement seal carefully. Do not touch polished seal faces.

IMPORTANT: Be sure that shaft shoulder does not damage polished face (see Figure 1).

6. Thoroughly clean all surfaces of seal seat cavity in adapter.
7. Using a clean cloth, wipe shaft and shaft sleeve to make certain that both parts are perfectly clean.
8. Wet the rubber portion of new seal seat with a light coating of soapy water. While wearing clean gloves or using a clean light rag, press seal seat squarely into adapter recess, use cardboard washer (usually supplied with new seal), place over polished surface and use a piece of pipe or dowel rod to press in firmly, but gently. Avoid scratching polished face.
9. Dispose of cardboard washer. Check again to see that polished surface is free of dirt and all other foreign particles and that it has not been scratched or damaged.
10. Wet inside rubber portion of new seal head with a light coating of soapy water. Slide head onto motor shaft with sealing surface facing seal seat. (See Figure 2).
11. Replace any impeller shims (Ref. No. 7) which may have been removed in disassembly. (See "Shim Adjustment" below.)
12. Screw impeller back into place, tightening until it is against shaft shoulder.
13. Replace impeller seal and fastener and tighten until snug.
14. Remount casing and casing seal on adapter.

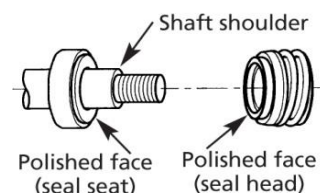

Figure 1 – Seal Replacement

Small Straight Centrifugal Pumps

SHIM ADJUSTMENT

1. When installing a replacement adapter (Ref. No.4), impeller (Ref. No. 8), or casing (Ref. No. 12) it may be necessary to vary number of impeller shims (Ref. No. 7) that will be required. This is easily done by adding one shim more than was removed and reassembling pump as described in "Mechanical Seal Replacement" section.

NOTE: When adding or removing shims, it is best to proceed with a 0.010" increment each time. While tightening unit together turn shaft; feel for shaft seizing. If shaft begins to seize before fasteners are completely tight, disassemble pump and remove one shim and repeat assembly.

2. Once having added one shim more than original, ensure that casing and adapter are firmly fitted (check fasteners Ref. No. 13). When pump shaft turns freely, add shims until it does strike, then remove a 0.010" shim. This should allow proper clearance.
3. Proper running clearance for impeller should be as close as possible to volute without striking; maximum clearance is 1/32" (0.032").
4. Follow above procedure until proper clearance is obtained. This will ensure maximum performance.

For Repair Parts contact dealer where pump was purchased.

Please provide following information:

-Model Number

-Serial Number (if any)

Part description and number as shown in parts list

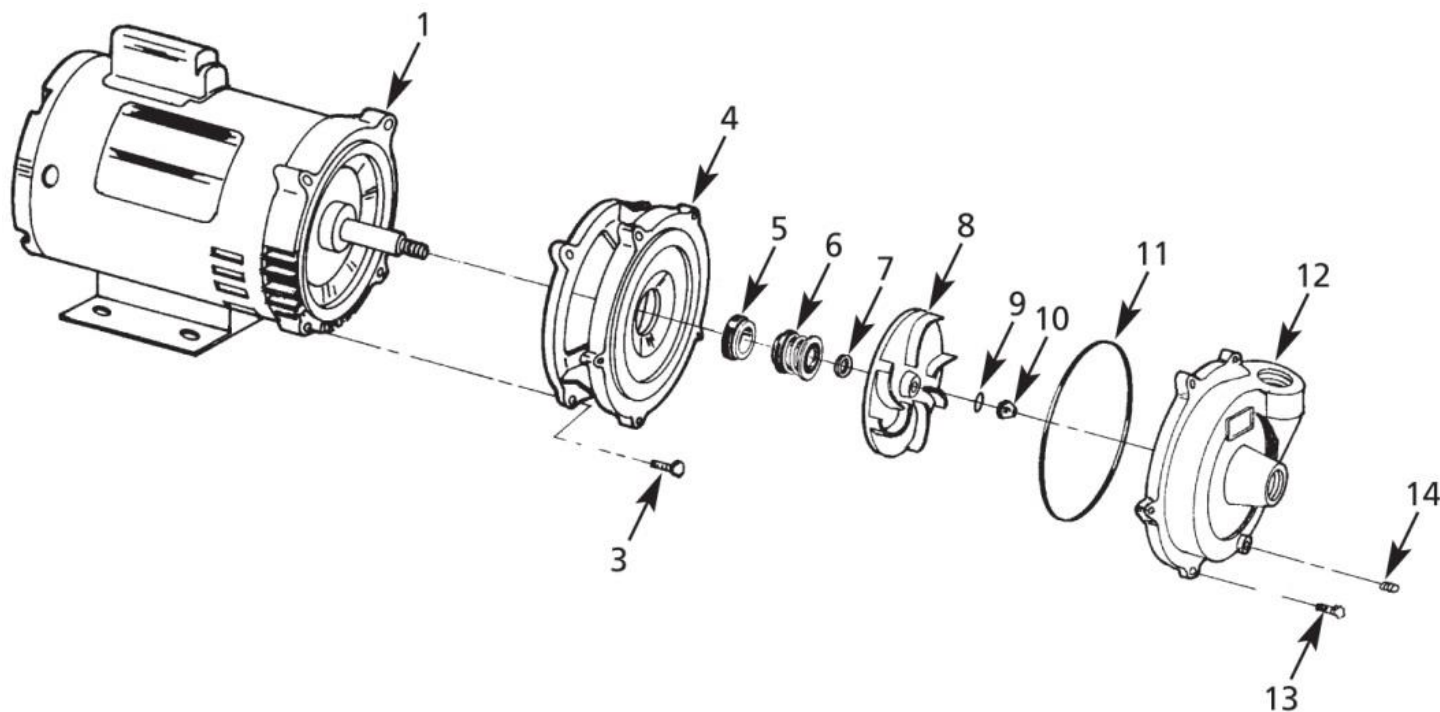

Figure 2 – Repair Parts Illustration

Repair Parts List

(ODP Models are for reference ONLY)

Ref. No.	Description		Part Number for Models:				Qty.
			368A (1/3HP)	368B (1/2HP)	370B (1/2HP)	370A (3/4HP)	
				3680 (1/3HP)	-	3701 (1/2HP)	
				-	-	3703 (1/2HP)	
				368C (1/2HP)	370F (1/2HP)	370C (3/4HP)	
1	Motor	-1 Phase ODP Disc' d	-	1626-008-00	-	1626-009-00	1
		-3 Phase ODP Disc' d	-	-	-	-	1
		-1 Phase TEFC	1626-300-00	1626-301-00	1626-301-00	1626-302-00	1
		-3 Phase TEFC	-	1626-307-00	1626-307-00	1626-308-00	1
3	Fastener		*	*	*	*	4
4	Adapter	-Cast Iron	3680-035-09	3680-035-09	3690-035-09	3690-035-09	1
		-Bronze	3680-036-09	3680-036-09	3690-036-09	3690-036-09	1
		-Stainless Steel	3680-034-09	3680-034-09	3690-034-09	3690-034-09	1
5 & 6	↔Shaft Seal Assembly	-Buna N	1640-161-90	1640-161-90	1640-161-90	1640-161-90	1
		-Viton®	1640-161-91	1640-161-91	1640-161-91	1640-161-91	1
7	Impeller Shim Set		1806-044-90	1806-044-90	1806-044-90	1806-044-90	1
8	Impeller		3680-015-01	3680-015-09	3700-013-02	3700-013-01	1
9	Impeller Seal	-Buna N	See Ref. No. KIT	See Ref. No. KIT	See Ref. No. KIT	See Ref. No. KIT	1
		-Viton®	See Ref. No. KIT	See Ref. No. KIT	See Ref. No. KIT	See Ref. No. KIT	1
10	Impeller Fastener		1784-001-00	1784-001-00	1784-001-00	1784-001-00	1
11	Casing Seal	-Buna N	See Ref. No. KIT	See Ref. No. KIT	See Ref. No. KIT	See Ref. No. KIT	1
		-Viton®	See Ref. No. KIT	See Ref. No. KIT	See Ref. No. KIT	See Ref. No. KIT	1
12	Casing	-Cast Iron	3680-002-09	3680-002-09	3700-002-09	3700-002-09	1
		-Bronze	3680-004-09	3680-004-09	3700-003-09	3700-003-09	1
		-Stainless Steel	3680-001-09	3680-001-09	3700-001-00	3700-001-00	1
13	Fastener		*	*	*	*	5
14	1/8" NPT Pipe Plug		*	*	*	*	1
KIT	O-Ring Seal Kit	-Buna N	3680-300-90	3680-300-90	3690-300-90	3690-300-90	1
		-Viton®	3680-300-91	3680-300-91	3690-300-91	3690-300-91	1

(includes Ref. Nos. 9 & 11)

(*) Standard Hardware Item, Available Locally

(↔) Seal assembly available as set only (includes seal head and seat).

For Repair Parts contact dealer where pump was purchased.

Please provide following information:

-Model Number

-Serial Number (if any)

Part description and number as shown in parts list

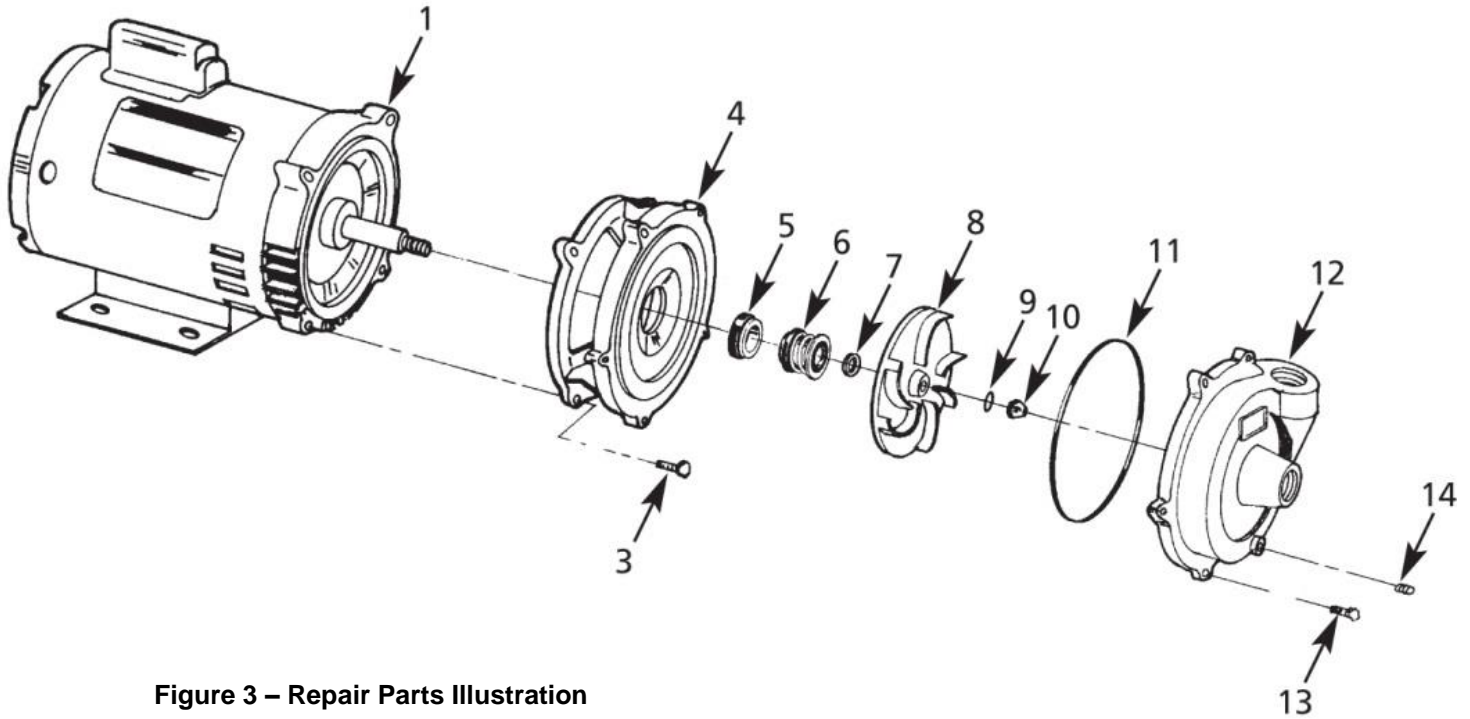

Figure 3 – Repair Parts Illustration

Repair Parts List

(ODP Models are for reference ONLY)

Ref. No.	Description		Part Number for Models:					Qty.
			3700 (3/4HP)	-	3691 (1HP)	3690 (1-1/2HP)		
			3702 (3/4HP)	-	3693 (1HP)	3692 (1-1/2HP)		
			370E (1HP)	369C (1HP)	369A (1-1/2HP)	369D (2HP)		
			370D (1HP)	369F (1HP)	369B (1-1/2HP)	369E (2HP)		
1	Motor	-1 Phase ODP Disc' d	1626-010-00	-	1626-011-00	1626-012-00	1	
		-3 Phase ODP Disc' d	-	-	-	1626-016-00	1	
		-1 Phase TEFC	1626-303-00	1626-303-00	1626-304-00	1626-305-00	1	
		-3 Phase TEFC	1627-309-00	1627-309-00	1627-310-00	1627-311-00	1	
3	Fastener		*	*	*	*	4	
4	Adapter	-Cast Iron	3690-035-00	3690-035-00	3690-035-00	3690-035-00	1	
		-Bronze	3690-036-09	3690-036-09	3690-036-09	3690-036-09	1	
		-Stainless Steel	3690-034-09	3690-034-09	3690-034-09	3690-034-09	1	
5 & 6	↔ Shaft Seal Assembly	-Buna N	1640-161-90	1640-161-90	1640-161-90	1640-161-90	1	
		-Viton®	1640-161-91	1640-161-91	1640-161-91	1640-161-91	1	
7	Impeller Shim Set		1806-044-90	1806-044-90	1806-044-90	1806-044-90	1	
8	Impeller		3700-013-09	3690-013-02	3690-013-01	3690-013-09	1	
9	Impeller Seal	-Buna N	See Ref. No. KIT	See Ref. No. KIT	See Ref. No. KIT	See Ref. No. KIT	1	
		-Viton®	See Ref. No. KIT	See Ref. No. KIT	See Ref. No. KIT	See Ref. No. KIT	1	
10	Impeller Fastener		1784-001-00	1784-001-00	1784-001-00	1784-001-00	1	
11	Casing Seal	-Buna N	See Ref. No. KIT	See Ref. No. KIT	See Ref. No. KIT	See Ref. No. KIT	1	
		-Viton®	See Ref. No. KIT	See Ref. No. KIT	See Ref. No. KIT	See Ref. No. KIT	1	
12	Casing	-Cast Iron	3700-002-09	3690-002-09	3690-002-09	3690-002-09	1	
		-Bronze	3700-003-09	3690-003-09	3690-003-09	3690-003-09	1	
		-Stainless Steel	3700-001-00	3690-001-09	3690-001-09	3690-001-09	1	
13	Fastener		*	*	*	*	5	
14	1/8" NPT Pipe Plug		*	*	*	*	1	
KIT	O-Ring Seal Kit	-Buna N	3690-300-90	3690-300-90	3690-300-90	3690-300-90	1	
		-Viton®	3690-300-91	3690-300-91	3690-300-91	3690-300-91	1	

(includes Ref. Nos. 9 & 11)

(*) Standard Hardware Item, Available Locally

(↔) Seal assembly available as set only (includes seal head and seat).