

Please read and save this Repair Parts Manual. Read this manual and the General Operating Instructions carefully before attempting to assemble, install, operate or maintain the product described. Protect yourself and others by observing all safety information. The Safety Instructions are contained in the General Operating Instructions. Failure to comply with the safety instructions accompanying this product could result in personal injury and/or property damage! Retain instructions for future reference. AMT reserves the right to discontinue any model or change specifications at any time without incurring any obligation.

©2017 AMT Pump Company, A Subsidiary of The Gorman-Rupp Company, All Rights Reserved.

Periodic maintenance and inspection is required on all pumps to ensure proper operation. Unit must be clear of debris and sediment. Inspect for leaks and loose bolts. Failure to do so voids warranty.

Self-Priming Centrifugal Pumps



Refer to pump manual 1808-634-00 for General Operating and Safety Instructions.

DESCRIPTION

These self-priming (to 20 ft. lift) (to 15 ft. lift on aluminum models without foot valve) are designed for general purpose liquid transfer. Pumps include a semi-open clog resistant impeller. Handle liquids from 40° to 180° F (4° to 82° C) with Buna N seals and 40° to 200° F (4° to 93° C) with Viton® seals. For use with non-flammable, non-abrasive liquids compatible with pump component materials.

PUMPS

Motorized units are direct coupled to a 3450 RPM motor. Single phase pump motors have automatic reset thermal protection. All models are manual mode and require field wiring; no controls are supplied. Check motor wiring before putting unit into operation (see motor nameplate for specific wiring diagram).

UNITS SHIPPED WITHOUT MOTOR

Some models are not equipped with motors. They are suitable for mounting to 3450 RPM, NEMA 56J face threaded shaft motors with counterclockwise rotation (looking at motor shaft). To find available horsepower of motor, multiply rated horsepower by service factor. This number must be equal to or greater than that required by pump.

ASSEMBLY

MOTOR (for units shipped without motor only)

1. If any parts are missing or damaged, do not attempt to assemble or operate pump until replacement parts are obtained and properly installed.
2. Verify that motor conforms to ALL standards specified in "Description".
3. Place motor in vertical position with shaft end up. Set adapter (Ref. No. 4) on top of motor.
4. See "Shaft Seal Replacement" and follow steps to complete assembly.

MAINTENANCE

⚠ WARNING

Make certain that unit is disconnected from power source before attempting to service or remove any components! If the power disconnect is out of sight, lock it in the open position and tag to prevent application of power.

MECHANICAL SEAL REPLACEMENT

Refer to Figures 1, 2 and 3

IMPORTANT: Always replace both the seal seat (Ref. No. 5) and the seal head (Ref. No. 6) to ensure proper mating of mechanical seal components!

NOTE: It is not necessary to remove piping from pump casing. The motor and impeller assembly are removed from back of casing.

1. Unthread cap screws (Ref. No. 3) and remove pump casing (Ref. No. 10) from adapter (Ref. No. 4).
2. The motor used with this pump is a 56J frame. It has a threaded shaft; impeller is screwed directly onto shaft. To unscrew the impeller (Ref. No. 9), turn counterclockwise (CCW) facing impeller.

NOTE: A screwdriver slot or two flats for use with an open end 7/16" wrench are provided at the rear of the motor shaft (remove bearing cap for access). To hold the motor shaft from turning, either insert a large screwdriver blade into the slot or use a 7/16" wrench across the flats. Before removing impeller, remove impeller nut (Ref. No. 13) and impeller seal washer (Ref. No. 14) (where applicable).

3. Remove the adapter from the motor mounting face. The seal head (Ref. No. 6) and impeller shims (Ref. No. 8) will come loose at this time.

IMPORTANT: Retain impeller shims for use when reassembling unit.

4. Push seal seat (Ref. No. 5) from the adapter recess with a screwdriver.
5. Clean the adapter recess before inserting a new seal seat.
6. Carefully wipe the ceramic surface of the new seal seat with a clean cloth.
7. Wet the rubber portion of the seal seat with a light coating of soapy water.
8. Press the new seal seat squarely into the cavity in the adapter. If the seal seat does not press squarely into the cavity, it can be adjusted into place by pushing on it with a piece of cardboard between the pipe and seal seat to avoid scratching the seal seat. (This is a lapped surface and must be handled very carefully).
9. After the seal seat is in place, be sure that it is clean and has not been marred.
10. Using a clean cloth, wipe the shaft and make certain that it is perfectly clean.
11. Secure the adapter (Ref. No. 4) on the motor mounting face. Carefully guide motor shaft through the seal seat.
12. Apply a light coating of soapy water to the inside rubber portion of seal head (Ref. No. 6) and slide onto the shaft (with the sealing face first) so that the rubber portion is just up over the shaft shoulder.
13. Replace any impeller shims which may have been removed in disassembly (See "Shim Adjustment").
14. Screw the impeller (Ref. No. 9) back in place, tightening until it is against the shaft shoulder.

NOTE: After impeller clearance has been set (See "Shim Adjustment"), place a new impeller seal washer onto exposed shaft. Screw impeller nut onto shaft and tighten (where applicable).

15. Remount the pump casing (Ref. No. 10) on the adapter (Ref. No. 4). (See "Shim Adjustment" if motor or impeller was replaced).

IMPORTANT: Always inspect the O-ring gasket (Ref. No. 7) for cracks or cuts when unit is disassembled; replace if damaged.

Self-Priming Centrifugal Pumps

SHIM ADJUSTMENT

When installing a replacement impeller (Ref. No. 9) or motor (Ref. No. 1), it may be necessary to adjust the number of shims (Ref. No. 8) to ensure proper running clearance between the impeller and the casing. Proceed as follow

NOTE: A proper running clearance is less than 0.010.

1. For impeller replacement, add one (1) shim in addition to the one (1) removed originally.
2. For motor replacement, add two (2) shims in addition to the shims removed during disassembly.
3. Reassemble the pump using MECHANICAL SEAL REPLACEMENT for reference.

IMPORTANT: Be sure that the casing is snugly in place and check the shaft to make sure it is turning freely (use the screwdriver slot in the motor to turn the shaft). If it turns freely, check to ensure that the casing cover and casing are fitted "metal to metal" where they meet on the outside. If they are not "metal to metal", tighten the fasteners (Ref. No. 3) and recheck the shaft for free turning.

Tighten carefully turning the shaft while tightening so that the motor bearings are not damaged in the event that too many shims were installed. If the shaft seizes before fasteners are completely tight, disassemble the pump and remove one (1) shim and repeat reassembly.

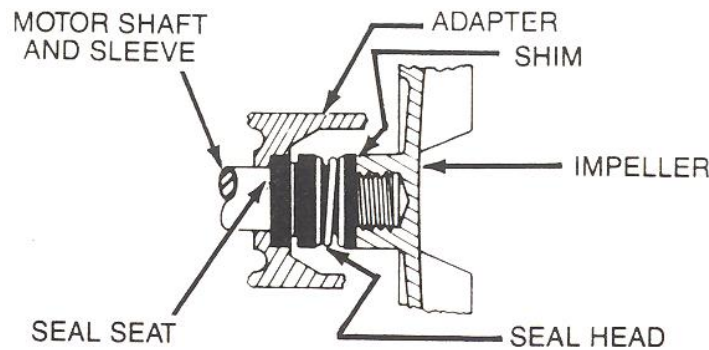

Figure 1- Mechanical Seal Replacement

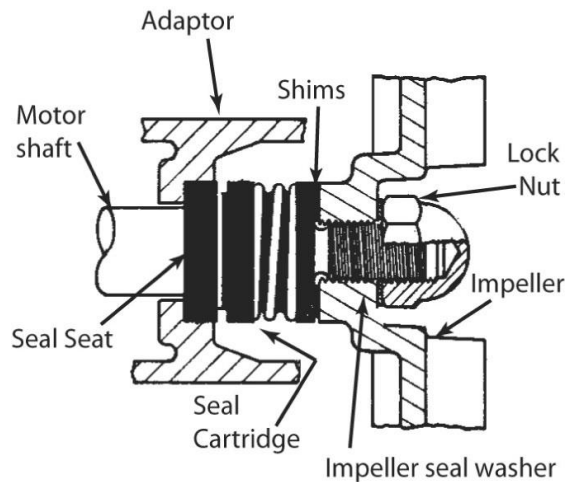

Figure 2- Models 2856, 2857, 285A, 285M, 285B, 285C, 285D, 285J, 285K, 285P

For Repair Parts contact dealer where pump was purchased.

Please provide following information:

- Model Number
- Serial Number (if any)

Part description and number as shown in parts list

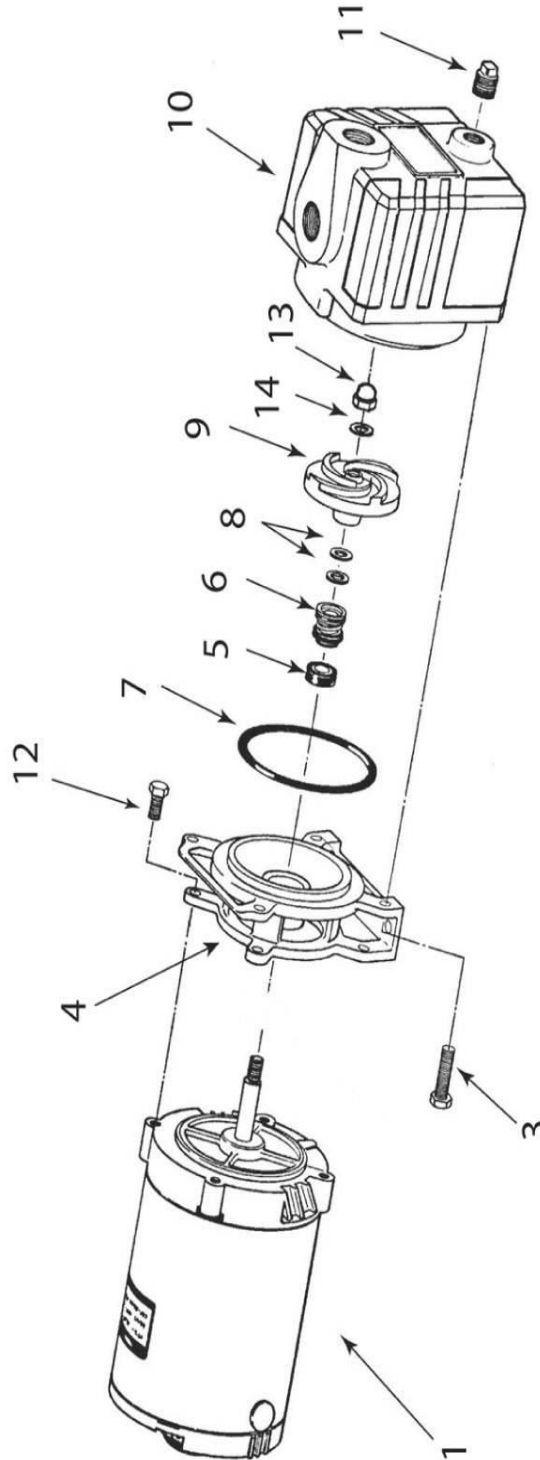

Figure 3 – Repair Parts Illustration

Repair Parts List

Ref. No.	Description	Part Number for Models:							Qty.
		2851-95 285E-95	2852-95 285F-95	2853-95 285G-95	2855-95 285H-95	2856-95 285J-95	2857-95 285K-95	285M-95 285P-95	
1	Motor ODP	1626-008-00	1626-009-00	1626-010-00	1626-011-00	1626-014-00	1626-015-00	1626-013-00	1
	Motor TEFC	1626-301-00	1626-302-00	1626-303-00	1626-304-00	1627-309-00	1627-310-00	1626-308-00	1
3	Fastener	*	*	*	*	*	*	*	4
4	Adapter	1560-000-01	1560-000-01	1560-000-01	1560-000-01	1560-000-01	1560-000-01	1560-000-01	1
5 & 6	↔ Shaft Seal Assembly	-Buna-N (standard)	1640-161-90	1640-161-90	1640-161-90	1640-161-90	1640-161-90	1640-161-90	1
		-Viton (optional)	1640-161-91	1640-161-91	1640-161-91	1640-161-91	1640-161-91	1640-161-91	1
		-Viton & Sil. Carb. (opt)	1641-165-91	1641-165-91	1641-165-91	1641-165-91	1641-165-91	1641-165-91	1
7	O-Ring	-Buna-N (standard)	1531-000-00	1531-000-00	1531-000-00	1531-000-00	1531-000-00	1531-000-00	1
		-Viton® (optional)	1532-000-00	1532-000-00	1532-000-00	1532-000-00	1532-000-00	1532-000-00	1
8	Impeller Shim Package	1657-000-90	1657-000-90	1657-000-90	1657-000-90	1657-000-90	1657-000-90	1657-000-90	1
9	Impeller	2850-010-01	2850-010-03	2850-010-05	2850-010-07	2850-010-06	2850-010-08	2850-010-04	1
10	Casing	1558-000-01	1558-000-02	1558-000-02	1558-000-03	1558-000-02	1558-000-03	1558-000-02	1
11	1/2" NPT Drain Plug	*	*	*	*	*	*	*	1
12	Fastener	*	*	*	*	*	*	*	4
13	Impeller Nut	N/A	N/A	N/A	N/A	1784-001-00	1784-001-00	1784-001-00	1
14	Impeller Seal Washer	N/A	N/A	N/A	N/A	1471-020-00	1471-020-00	1471-020-00	1

(*) Standard Hardware Item, Available Locally

(↔) Seal assembly available as set only (includes seal head and seat).