

Please read and save this Repair Parts Manual. Read this manual and the General Operating Instructions carefully before attempting to assemble, install, operate or maintain the product described. Protect yourself and others by observing all safety information. The Safety Instructions are contained in the General Operating Instructions. Failure to comply with the safety instructions accompanying this product could result in personal injury and/or property damage! Retain instructions for future reference. AMT reserves the right to discontinue any model or change specifications at any time without incurring any obligation.

©2015 AMT Pump Company, A Subsidiary of The Gorman-Rupp Company, All Rights Reserved.

Periodic maintenance and inspection is required on all pumps to ensure proper operation. Unit must be clear of debris and sediment. Inspect for leaks and loose bolts. Failure to do so voids warranty.

# Self-Priming Centrifugal Pedestal Pumps

Refer to pump manual 1808-635-00 for General Operating and Safety Instructions.

## DESCRIPTION

This self-priming (to 20 ft. lift) centrifugal pump is used for direct coupling or pulley drive medium head applications. Specific applications include liquid transfer, irrigations, dewatering, etc. Clog-resistant impeller can handle sediment laden liquids and semi-solids up to 3/8" diameter. Handles liquids from 40° to 180° F (4° to 82° C). For use with nonflammable, non-abrasive liquids compatible with pump component materials.

## SPECIFICATIONS

Suction Inlet	1¼" NPT
Discharge Outlet	1¼" NPT
Shaft Diameter	5/8"
Keyway	3/16 x 3/32"
Dimensions (overall)	7 ¾" H x 6 ⅝" W x 11" L
Weight (approximate)	23 lbs.
Basic Construction	Cast Iron
Mechanical Seal	Buna-N w/ Carbon Ceramic Faces
Max. Suction Lift	14 ft. @ 1750, 2300 and 2800 RPM 20 ft. @ 3450 RPM

## Performance and Pulley Drive Chart

Drive	PERFORMANCE								PULLEY DRIVE		
	Recommended	10'	15'	20'	30'	40'	50'	60'	*Max. Head	Motor Pulley Size "A" Section V-Belt	Pump Pulley Size "A" Section V-Belt
1/4HP @ 1750 RPM	1,240	120	-	-	-	-	-	-	16 ft.	2 ½" for 3500 RPM Motor 3" for 1750 RPM Motor	5" for 3500 RPM Motor 3" for 1750 RPM Motor
1/3 HP @ 2300 RPM	2,245	1,740	1,040	-	-	-	-	-	28 ft.	3" for 3500 RPM Motor 4" for 1750 RPM Motor	4 ½" for 3500 RPM Motor 3" for 1750 RPM Motor
1/2 HP @ 2800 RPM	3,040	2,740	2,325	1,220	-	-	-	-	34 ft.	2 ½" for 3500 RPM Motor 4" for 1750 RPM Motor	3" for 3500 RPM Motor 2 ½" for 1750 RPM Motor
1 HP @ 3450 RPM	3,950	3,780	3,560	2,970	2,170	1,160	-	-	55 ft.	3" for 3500 RPM Motor 6" for 1750 RPM Motor	3" for 3500 RPM Motor 3" for 1750 RPM Motor

(\*) Shut-off; to convert to psi, divide by 2.31.

# Self-Priming Centrifugal Pedestal Pumps

## MAINTENANCE

### **▲ WARNING**

**Make certain that unit is disconnected from power source before attempting to service or remove any components!**

## MECHANICAL SEAL REPLACEMENT

Refer to Figure 1.

**IMPORTANT:** Always replace both the seal seat and the seal head to ensure proper mating of components! Handle the mechanical seal replacement carefully as the precision lapped faces can be damaged easily.

1. Disassemble the bearing housing (Ref. No. 5) and gasket (Ref. No. 6) from the pump casing (Ref. No. 11) by removing the 4 hex head cap screws (Ref. No. 13).
2. Unscrew the impeller, (right hand thread, Ref. No. 10).
3. Carefully pry up on the seal cartridge (Ref. No. 8) using two large screwdrivers. Often, this portion of the seal can be removed by pulling off with your fingers.
4. Remove the shaft bearing assembly (Ref. No. 3) by first removing the snap ring (Ref. No. 1) and shims. Push the shaft bearing assembly out of the bearing housing by tapping on the threaded end of the shaft with a rawhide mallet or block of wood and hammer. As shaft is being pulled from the housing, the shaft slinger (Ref. No. 4) between the seal and the bearing will fall free.
5. Pry the seal seat (Ref. No. 7) from the cavity in the bearing housing.
6. Replace shaft bearing assembly by sliding the assembly into the housing, threaded shaft first. As shaft end emerges from bearing cavity before it enters into seal cavity, slip the rubber slinger washer (Ref. No. 4) up from the underside, over the end of the shaft. Some manipulation through the seal cavity opening may be required. Push shaft bearing assembly home by gently tapping on keyway end of shaft with a rawhide mallet. Replace snap ring and shims.
7. Carefully wipe the surface of the ceramic seat with a clean cloth.
8. Wet the rubber portion of the ceramic seat with a light coating of soapy water.
9. Press the seal seat squarely into the cavity in the bearing housing. If the seal seat does not press squarely into the cavity, it can be adjusted in place by pushing on it with a piece of pipe.

**NOTE:** Always use a piece of cardboard between the pipe and the seal seat to avoid scratching the seal seat. This is a lapped surface and must be handled very carefully.

10. After the seal is in place, be sure that the face is clean and has not been scratched or cracked.
11. Using a clean cloth, wipe the shaft and make sure that it is perfectly clean.
12. Apply a light coating of soapy water on the inside of the rubber drive ring inside the seal cartridge assembly. Slide the seal assembly onto the shaft (with the sealing face first), sliding the rubber drive ring just up over the shaft shoulder. Do not touch or wipe the seal head.
13. Replace any shim washers (Ref. No. 9) you may have removed in disassembly.
14. Screw the impeller back in place, tightening until it is against the shoulder provided on the shaft.
15. Replace pump casing on the bearing housing, using a new gasket to prevent leakage. Turn shaft by hand to ensure free rotation. If striking of the impeller on the pump casing is noted, disassemble and remove shim washers as required.

## BEARING HOUSING SERVICE

1. Remove front pump assembly as described under "Mechanical Seal Replacement"
2. Remove shaft/bearing assembly (Ref. No. 3) by first removing retaining ring (Ref. No. 1). Push shaft/bearing assembly out of pedestal (Ref. No. 5) by rapping on threaded end of shaft with a rawhide mallet, or block of wood and a hammer.
3. Replace shaft/bearing assembly by sliding assembly into housing threaded end first. Push shaft bearing assembly completely in by gently tapping on keyway end of shaft with a rawhide mallet. Replace retaining ring.
4. Reassemble pump as described in "Mechanical Seal Replacement".

## SHIM ADJUSTMENT

1. When installing a replacement, impeller (Ref. No. 5) or casing (Ref. No. 11) it may be necessary to vary the number of impeller shims (Ref. No. 9) that will be required. This is easily done by adding one shim more than was removed and reassembling pump as described in MECHANICAL SEAL REPLACEMENT section.

**NOTE:** When adding or removing shims, it is best to proceed with a 0.010" increment each time. While tightening unit together, turn shaft and feel for shaft seizing. If shaft begins to seize before fasteners are completely tight, disassemble pump and remove one shim and repeat assembly.

2. Once having added one shim more than original, ensure that casing and pedestal are firmly fitted (check fasteners Ref. No. 13). When pump shaft turns freely add shims until it does strike, then remove a 0.010" shim. This should allow proper clearance.
3. Proper running clearance for impeller should be as close as possible to volute without striking; maximum clearance is 1/32" (0.032").
4. Follow above procedure until proper clearance is obtained. This will ensure maximum performance.

# For Repair Parts contact dealer where pump was purchased.

Please provide following information:

-Model Number

-Serial Number (if any)

Part description and number as shown in parts list

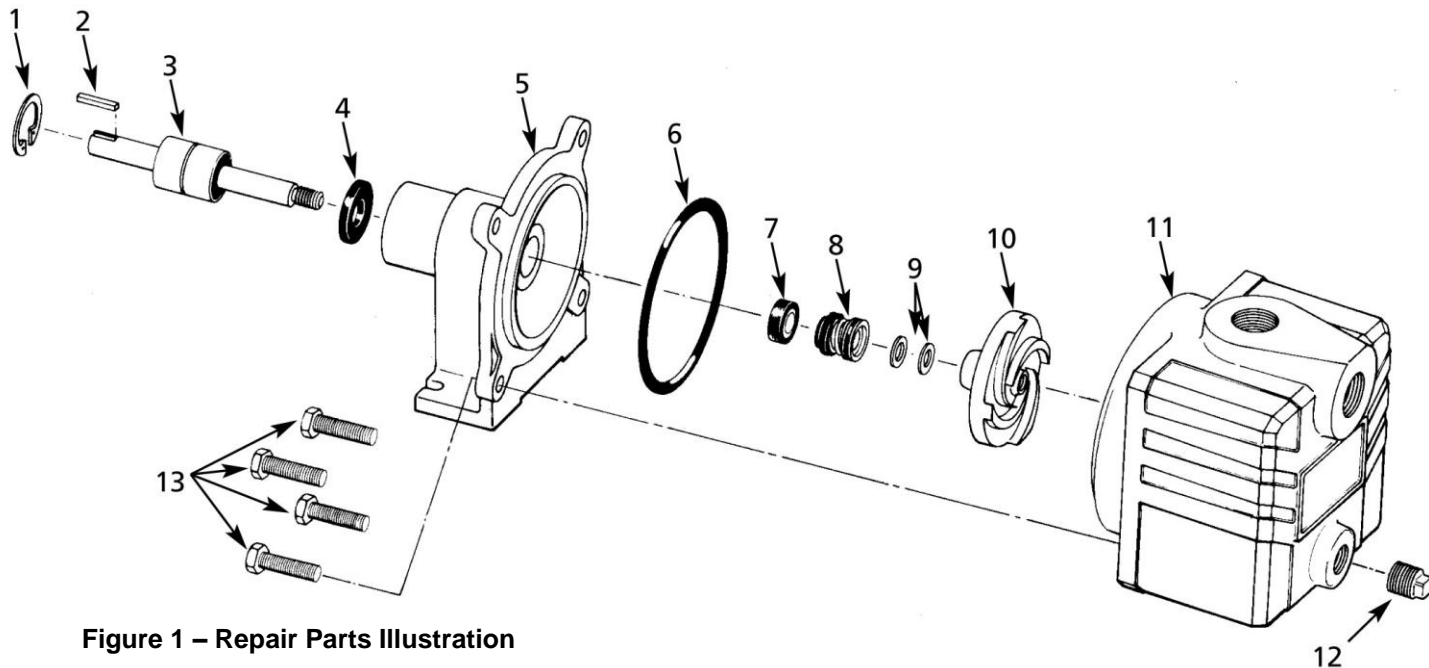

Figure 1 – Repair Parts Illustration

## Repair Parts List

Ref. No.	Description	Part No.	Qty.
1	Snap Ring	1516-000-00	1
2	3/16" Square Shaft Key	1517-000-00	1
3	† Shaft & Bearing Assembly	1509-140-90	1
4	Slinger Washer (not required)	1534-000-00	1
5	Bearing Housing/Adapter	1562-000-01	1
6	Gasket, Buna-N	1531-000-00	1
	Gasket, Viton (optional)	1532-000-00	1
7,8	◇ Seal Assembly, Buna-N	1640-161-90	1
	◇ Seal Assembly, Viton (optional)	1640-161-91	1
9	Impeller Shim Kit	1657-000-90	-
10	Impeller	2850-010-03	1
11	Casing	1558-000-02	1
12	1/2" NPT Drain Plug	*	1
13	3/8" - 16 x 2" Hex Head Cap Screw	*	4
△	Bearing Shim Kit	1696-003-90	-

(\*) Standard Hardware Item, Available Locally

(◇) Seal assembly available as set only (includes seal head and seat).

(†) Shaft and bearings not available separately.

(△) Not Shown