

Please read and save this Repair Parts Manual. Read this manual and the General Operating Instructions carefully before attempting to assemble, install, operate or maintain the product described. Protect yourself and others by observing all safety information. The Safety Instructions are contained in the General Operating Instructions. Failure to comply with the safety instructions accompanying this product could result in personal injury and/or property damage! Retain instructions for future reference. AMT reserves the right to discontinue any model or change specifications at any time without incurring any obligation.

©2016 AMT Pump Company, A Subsidiary of The Gorman-Rupp Company, All Rights Reserved.

Periodic maintenance and inspection is required on all pumps to ensure proper operation. Unit must be clear of debris and sediment. Inspect for leaks and loose bolts. Failure to do so voids warranty.

Self-Priming Centrifugal Pumps

High Volume Dewatering Cast Iron Models



Refer to pump manual 1808-634-00 for General Operating and Safety Instructions.

DESCRIPTION

These centrifugal pumps are self-priming (to 20 ft. lift) units designed for high volume liquid transfer, irrigation, dewatering, lawn sprinkling, etc. These pumps can also accommodate semi-solids (up to 3/8" dia.), sediment laden liquids, and liquids with entrained air or gases. Units are constructed of cast iron and include Buna elastomers (Viton® elastomers optional, contact factory for availability). They are direct coupled to NEMA 56J frame, 3450 RPM motors which require field wiring, no controls are supplied. Each pump is equipped with a flapper valve to shorten re-prime time after initially filling casing with liquid. Handles liquids from 40° to 180° F (4° to 82° C). For use with nonflammable, non-abrasive liquids compatible with pump component materials.

MAINTENANCE

▲ WARNING

Make certain that unit is disconnected from power source before attempting to service or remove any components!

NOTE: The pump casing should be removed and inspected periodically to ensure that any foreign material is not clogging internal pump parts. This unit is equipped with a dual volute pump casing. One of the volutes runs 180°, all the way from the side opposite the discharge into the discharge through a completely enclosed passageway. If foreign material clogs this area, it can be dislodged by using a wire or long spring.

MECHANICAL SEAL REPLACEMENT

Refer to Figures 1 and 2

IMPORTANT: Always replace both seal seat (Ref. No. 7) and seal head (Ref. No. 8) to ensure proper mating of components! Recommend replacing casing seal (Ref. No.6) if wear or damage is present.

1. Unthread fasteners (Ref. No. 5) and remove casing (Ref. No. 12) and casing seal (Ref. No. 6) from adapter (Ref. No. 4)
2. Unscrew impeller fastener (Ref. No. 11) and impeller (Ref. No. 10) separately by turning each counterclockwise.

NOTE: Most motors use an open end 7/16" wrench across flats on rear of motor shaft (remove bearing cap for access) to prevent shaft from turning. Other motor shafts have a screwdriver slot instead of flats.

3. Unscrew fasteners (Ref. Nos. 3 & 16) and remove adapter, foot (Ref. No. 17) and handle (Ref. No. 2) from motor (Ref. No. 1) mounting face. Seal head will come loose at this time.
4. Push seal seat from adapter recess with a screwdriver.
5. Clean adapter recess before inserting new seal seat.
6. Carefully wipe polished surface of new seal seat with a clean cloth.
7. Wet rubber portion of seal seat with a light coating of soapy water.
8. Press new seal seat squarely into cavity in adapter. If seal seat does not press squarely into cavity, it can be adjusted in place by pushing on it with a piece of pipe. Always use a piece of cardboard between pipe and seal seat to avoid scratching seal seat. (This is a lapped surface and must be handled very carefully.)

9. After seal seat is in place, ensure that it is clean and has not been marred.
10. Using a clean cloth, wipe shaft and make certain that it is perfectly clean.
11. Secure adapter, foot and handle on motor mounting face. Carefully guide motor shaft through seal seat.
12. Apply a light coating of soapy water to inside rubber portion of seal head and slide onto shaft (with sealing face first) so that rubber portion is just up over shaft shoulder.

▲ CAUTION

Do not touch or wipe polished face of seal head.

13. Replace any impeller shims (Ref. No. 9) that may have been removed in disassembly. (See "Shim Adjustment" below).
14. Screw impeller back into place, tightening until it is against shaft shoulder.
15. Replace impeller nut and tighten until snug.
16. Remount casing and casing seal on adapter.

SHIM ADJUSTMENT

When installing a replacement impeller (Ref. No. 10) or motor (Ref. No. 1), it may be necessary to adjust number of shims (Ref. No. 9) to ensure proper running clearance between impeller and casing. Proceed as follows:

NOTE: A proper running clearance is less than 0.010".

1. For impeller replacement, add one 0.010" shim in addition to those removed originally.
2. For motor replacement, add two 0.010" shims in addition to those removed during disassembly.
3. Reassemble the pump as described in steps 15, 16 & 17.

IMPORTANT: Be sure that the casing is snugly in place and check shaft to make sure it is turning freely (use screwdriver slot in motor to turn shaft). If it turns freely, check to ensure that adapter and casing are fitted tight together. If they are not, tighten fasteners (Ref. Nos. 3, 5 and 17) and recheck shaft for free turning. Tighten carefully, turning shaft while tightening so that motor bearings are not damaged in the event that too many shims were installed. If shaft seizes before fasteners are completely tight, disassemble pump and remove one shim and repeat reassembly.

Self-Priming Centrifugal Pumps

FLAPPER VALVE ASSEMBLY REPLACEMENT

Remove bolts (Ref. No. 19) and suction plate (Ref. No. 15). Replace flapper valve assembly (Ref. No. 14). Remount suction plate and bolts; tighten bolts evenly to ensure proper seal.

Self-Priming Centrifugal Pumps

For Repair Parts contact dealer where pump was purchased.

Please provide following information:

-Model Number

-Serial Number (if any)

Part description and number as shown in parts list

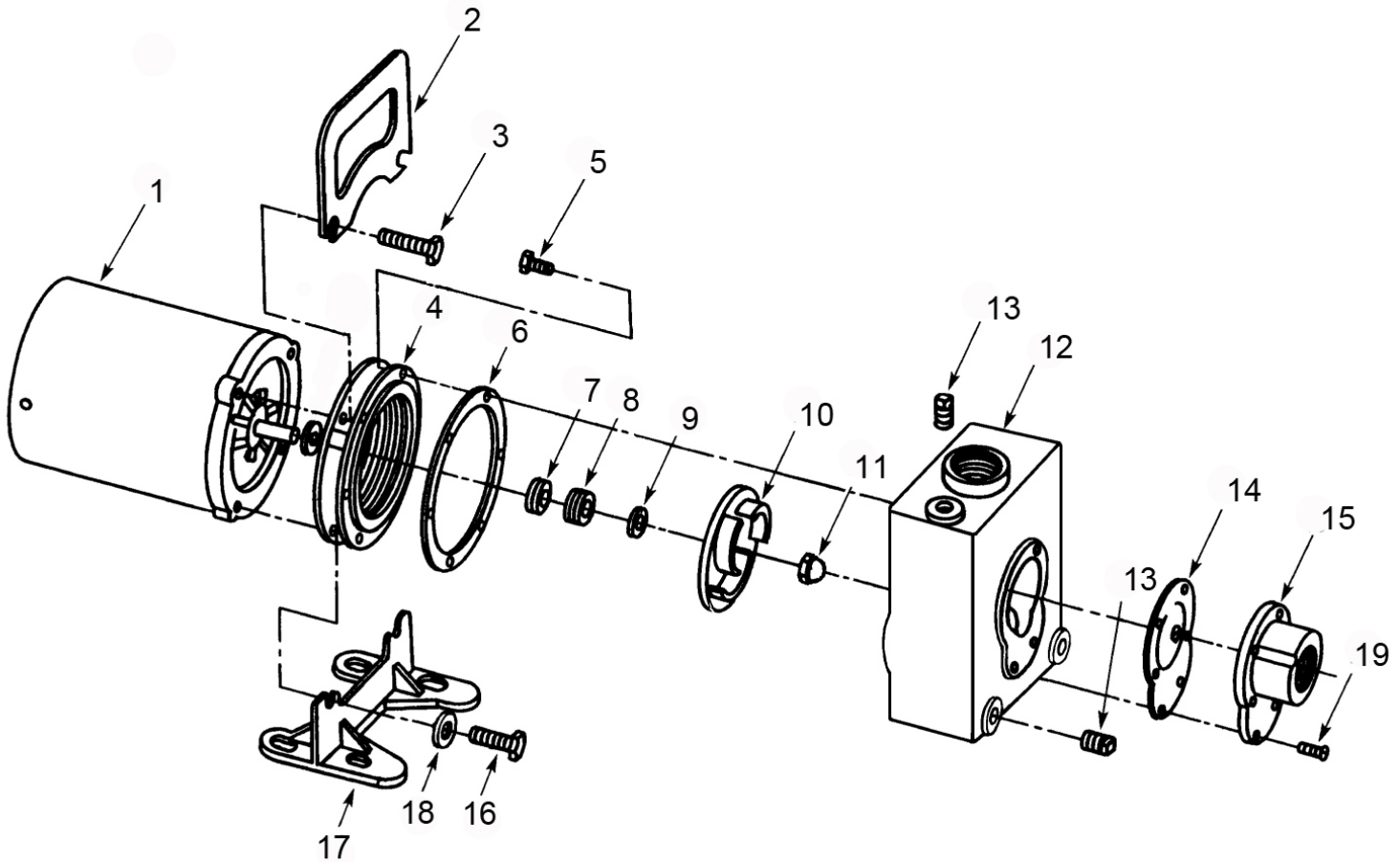

Figure 2 - Repair Parts Illustrations

Repair Parts List

Ref. No.	Description	Part Number for Models			Qty
		2762-95 (1-1/2HP)	2761-95 (2HP)	2767-95 (3HP)	
		2764-95 (1-1/2HP)	2763-95 (2HP)	2766-95 (3HP)	
		276B-95 (2HP)	276A-95 (3HP)		
		276D-95 (2HP)	276C-95 (3HP)		
1	Motor - 1 Phase ODP	1626-012-00	1626-024-00	1626-026-00	1
	Motor - 3 Phase ODP	1626-016-00	1626-025-00	1626-027-00	1
	Motor - 1 Phase TEFC	1626-305-00	1626-306-00	-	1
	Motor - 3 Phase TEFC	1627-311-00	1627-312-00	-	1
2	Handle	1515-000-00	1515-000-00	1515-000-00	1
3	Fastener	Incl. w/Ref 4	Incl. w/Ref 4	Incl. w/Ref 4	2
4	Adapter Kit (includes Ref. Nos. 3, 4 and 5)	2820-030-95	2820-030-95	2820-030-95	1
5	Fastener	Incl. w/Ref 4	Incl. w/Ref 4	Incl. w/Ref 4	4
6	Casing Seal	Incl. w/Ref KIT	Incl. w/Ref KIT	Incl. w/Ref KIT	1
7 & 8	Shaft Seal Assembly - Buna-N	1640-161-90 & Incl. w/Ref KIT	1640-161-90 & Incl. w/Ref KIT	1640-161-90 & Incl. w/Ref KIT	1
	Shaft Seal Assembly - Viton	1640-161-91 & Incl. w/Ref KIT	1640-161-91 & Incl. w/Ref KIT	1640-161-91 & Incl. w/Ref KIT	1
9	Impeller Shim Set	1657-000-90	1657-000-90	1657-000-90	1
10	Impeller - 1 Phase	2820-011-09	2820-011-0B	1496-002-02	1
	Impeller - 3 Phase	2820-011-0A	2820-011-0C	1496-002-02	1
11	Impeller Fastener	1784-001-00	1784-001-00	1784-001-00	1
12	Casing Kit - Buna-N	2760-001-B5	2760-001-B5	2760-001-B5	1
	Casing Kit - Viton (includes Ref. Nos. 5, 13, 14 and 15)	2760-001-V5	2760-001-V5	2760-001-V5	1
13	Pipe Plug	*	*	*	3
14	Flapper Valve Assembly - Buna-N	1683-000-90 & Incl. w/Ref KIT	1683-000-90 & Incl. w/Ref KIT	1683-000-90 & Incl. w/Ref KIT	1
	Flapper Valve Assembly - Viton	1683-000-91 & Incl. w/Ref KIT	1683-000-91 & Incl. w/Ref KIT	1683-000-91 & Incl. w/Ref KIT	1
15	Suction Plate	1487-000-01	1487-000-01	1487-000-01	1
16	Fastener	*	*	*	2
17	Foot	1506-000-00	1506-000-00	1506-000-00	1
18	Washer	*	*	*	2
19	Fastener	*	*	*	4
KIT	Seal Kit - Buna-N (standard)	2760-304-95	2760-304-95	2760-304-95	1
	Seal Kit - Viton (optional) (includes Ref. Nos. 6, 7, 8 and 14)	2760-305-95	2760-305-95	2760-305-95	1

(* Standard hardware item, available locally.