

Please read and save this Repair Parts Manual. Read this manual and the General Operating Instructions carefully before attempting to assemble, install, operate or maintain the product described. Protect yourself and others by observing all safety information. The Safety Instructions are contained in the General Operating Instructions. Failure to comply with the safety instructions accompanying this product could result in personal injury and/or property damage! Retain instructions for future reference. AMT reserves the right to discontinue any model or change specifications at any time without incurring any obligation.

©2015 AMT Pump Company, A Subsidiary of The Gorman-Rupp Company, All Rights Reserved.

Periodic maintenance and inspection is required on all pumps to ensure proper operation. Unit must be clear of debris and sediment. Inspect for leaks and loose bolts. Failure to do so voids warranty.

1-Inch Dewatering Pump

Refer to pump manual 1808-633-00 for General Operating and Safety Instructions.



DESCRIPTION

1" dewatering pumps are 4-cycle engine driven, self-priming to 20 ft. lift and portable. Pump construction materials include: aluminum, plastic and steel. Shaft seal has Buna N elastomers, carbon head and ceramic seat. Handles liquids from 40° to 180° F (4° to 82° C). For use with nonflammable, non-abrasive liquids compatible with pump component materials.

▲ WARNING

To prevent accidental starting always remove the spark plug, or disconnect and ground the spark plug wire before attempting to service or remove any component.

MECHANICAL SEAL REPLACEMENT

Refer to Figures 1 and 2

IMPORTANT: Always replace the seal seat and seal head (Ref. No. 10) to ensure proper mating of mechanical seal components!

1. Unthread fasteners (Ref. Nos. 13 and 14). Remove casing (Ref. No. 1) and casing seal (Ref. No. 11) from adapter (Ref. No. 6).
2. Unscrew impeller (Ref. No. 8) from the engine shaft and remove the impeller shims (Ref. No. 9).

NOTE: To keep the shaft from turning, remove the shroud from engine and hold the flywheel in place.

3. Unthread fasteners (Ref. No. 16) from engine mounting face.
4. Push seal seat from the adapter recess with a screwdriver.
5. Clean the adapter recess before inserting a new seal seat.
6. Carefully wipe the ceramic surface of the new seal seat with a clean cloth.
7. Wet the rubber portion of the seal with a light coating of soapy water.
8. Press the new seal seat squarely into cavity in the adapter. If the seal seat does not press squarely into the cavity, it can be adjusted in place by pushing on it with the end of a piece of pipe. Always use a piece of cardboard between the pipe and the seal seat to avoid scratching the seal seat. (This is a lapped surface and must be handled very carefully.)
9. After the seal seat is in place, be sure that it is clean and has not been marred.
10. Using a clean cloth, wipe the shaft and make certain that it is perfectly clean.
11. Secure the adapter on the engine mounting face.

▲ CAUTION

Tighten fasteners EVENLY to avoid cocking rabbet on engine mounting.

12. Apply a light coating of soapy water to the inside rubber portion of seal head and slide onto engine shaft.

▲ CAUTION

Do not touch or wipe the face of the carbon (black) part of the seal cartridge.

13. Replace impeller shims.

14. Screw impeller back in place, tightening until it is against the shoulder.
15. Install casing seal and remount the pump casing on adapter.

SHIM ADJUSTMENT

1. When installing a replacement engine, adapter, impeller, volute or casing, it may be necessary to vary the number of impeller shims (Ref. No. 9) that will be required. This is easily done by adding one shim more than was removed and reassembling the pump as described in MECHANICAL SEAL REPLACEMENT section.

NOTE: Remove spark plug wire from engine and ground. While tightening the unit together, turn the shaft (by pulling on the recoil starter, etc.); feel for the shaft seizing. If shaft begins to seize before the fasteners are completely tight, disassemble the pump and remove one shim and repeat assembly.

2. Once having added one shim more than original, ensure that the volute (Ref. No. 7) and adapter (Ref. No. 6) are firmly fitted (check fasteners Ref. Nos. 13 & 14). When engine turns freely, add shims until it does strike, then remove one shim. This should allow the proper clearance.
3. Proper running clearance for the impeller should be as close as possible to volute without striking.
4. Follow the above procedure until proper clearance is obtained. This will ensure maximum performance.

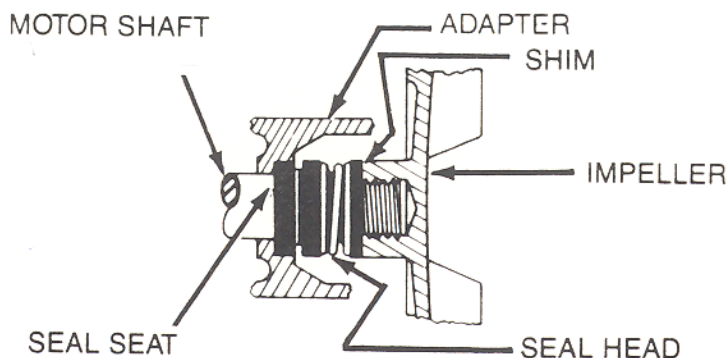

Figure 1 - Mechanical Seal Replacement

1-Inch Dewatering Pump

For Repair Parts contact dealer where pump was purchased.

Please provide following information:

-Model Number

-Serial Number (if any)

Part description and number as shown in parts list

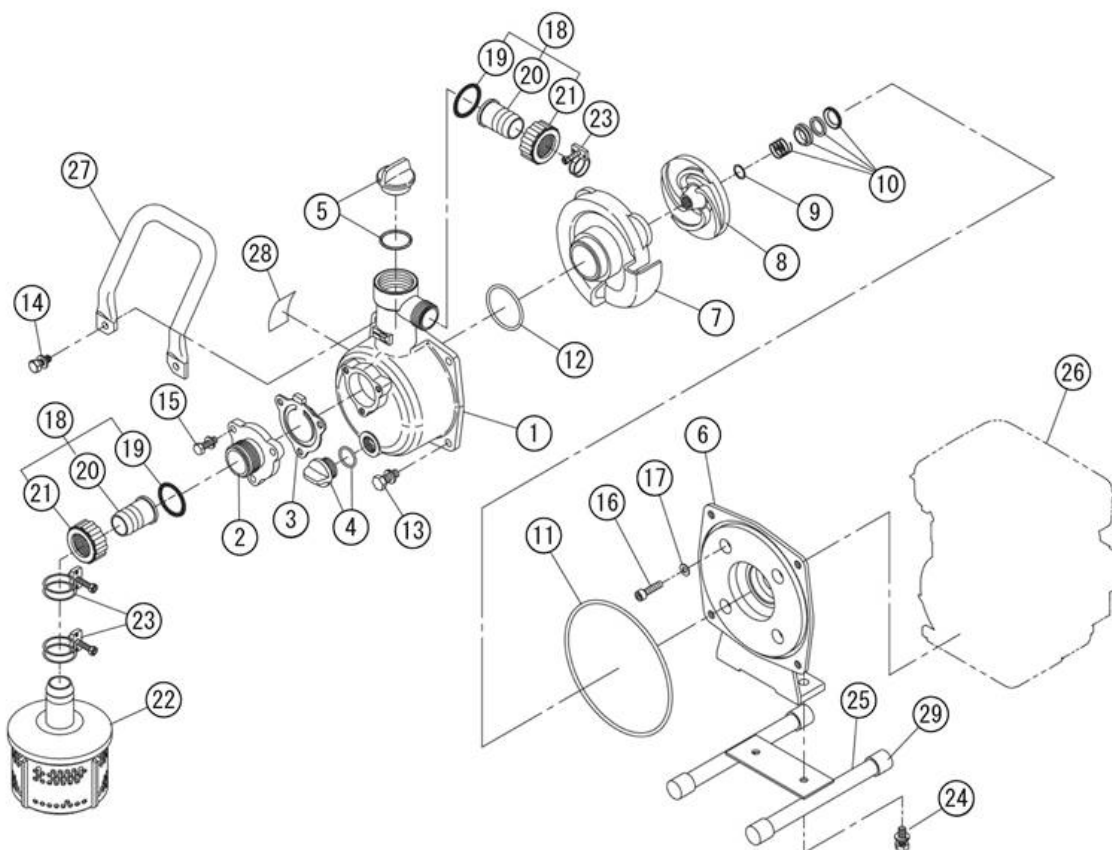

Figure 2 - Repair Parts Illustrations

Repair Parts List

| Ref No. | Description | 1G1XH | Qty |
|---------|---|------------------|-----|
| 1 | Pump Casing Kit (includes Ref. Nos. 13 and 14) | 1G1X-001-96 | 1 |
| 2 | Suction Flange Kit (includes Ref. No. 15) | 1G1X-050-96 | 1 |
| 3 | Check Valve Kit | 1G1X-070-90 | 1 |
| 4 | Drain Plug Kit (includes Ref. No. 5) | 1G1X-170-90 | 1 |
| 5 | Fill Plug | Incl. w/ Ref. 4 | |
| 6 | Adapter Kit (includes Ref. Nos. 16 and 17) | 1G1X-030-96 | 1 |
| 7 | Volute Kit | 1G1X-150-96 | 1 |
| 8 | Impeller Kit (includes Ref. No. 9) | 1G1X-010-96 | 1 |
| 9 | Impeller Shims | Incl. w/ Ref. 8 | |
| 10 | Seal Kit (includes Ref. Nos. 11 and 12) | 1G1X-300-90 | 1 |
| 11, 12 | Seal/O-Ring | Incl. w/ Ref. 10 | |
| 13, 14 | Fastener | Incl. w/ Ref. 1 | |
| 15 | Fastener | Incl. w/ Ref. 2 | |
| 16 | Fastener | Incl. w/ Ref. 6 | |
| 17 | Seal Washer | Incl. w/ Ref. 6 | |
| 18 | Hose Nipple Kit (includes Ref. Nos. 19, 20, 21, 22, 23 and 30) | 1G1X-172-90 | 1 |
| 19 | Seal/O-Ring | Incl. w/ Ref. 18 | |
| 20 | Hose Nipple | Incl. w/ Ref. 18 | |
| 21 | Coupling | Incl. w/ Ref. 18 | |
| 22 | Strainer | Incl. w/ Ref. 18 | |
| 23 | Hose Clamp | Incl. w/ Ref. 18 | |
| 24 | Fastener | Incl. w/ Ref. 25 | |
| 25 | Base Kit (includes Ref. Nos. 24, 27 and 29) | 1G1X-100-90 | 1 |
| 26 | Engine | Replace Pump | |
| 27 | Handle | Incl. w/ Ref. 25 | |
| 28 | Nameplate | N/A | |
| 29 | Cap | Incl. w/ Ref. 25 | |
| 30 | Discharge Garden Hose Adapter (not shown) | Incl. w/ Ref. 18 | |