

# STA-RITE®

## DURA-GLAS and MAX-E-GLAS™ CENTRIFUGAL PUMPS with TRAP

O W N E R ' S M A N U A L

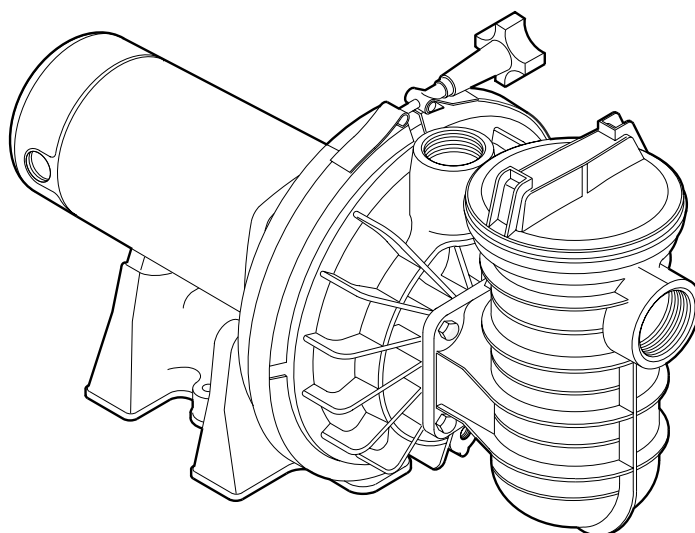

---

INSTALLATION, OPERATION & PARTS

### Series

PE  
PEA  
P2R  
P2RA

**This manual should be furnished to the end user of this pump; its use will reduce service calls and chance of injury and will lengthen pump life.**

---

### Sta-Rite Pool/Spa Group

293 Wright Street, Delavan, WI 53115

International: 262-728-5551, FAX: 262-728-7550

www.starite.com

Union City, TN • Delavan, WI • Mississauga, ON

© 2006, Sta-Rite Industries

S413 (Rev. 3/1/06)

# 'PE' and 'P2R' SERIES PUMPS WITH TRAP

To avoid unneeded service calls, prevent possible injuries, and get the most out of your pump, **READ THIS MANUAL CAREFULLY!**

The Sta-Rite 'PE' and 'P2R' Series Self-priming Centrifugal pumps:

- Are designed for use with swimming pools or as centrifugal pumps.
- Are excellent performers; durable, reliable.

## Table of Contents

Safety Instructions .....	2-3
Installation.....	3-5
Electrical .....	5-8
Operation .....	9-10
Storage/Winterizing .....	10
Pump Service .....	10-11
Troubleshooting Guide .....	12
Repair Parts List .....	13-15
Warranty .....	16

# READ AND FOLLOW SAFETY INSTRUCTIONS!

**⚠** This is the safety alert symbol. When you see this symbol on your system or in this manual, look for one of the following signal words and be alert to the potential for personal injury.

**⚠ DANGER** warns about hazards that **will** cause death, serious personal injury, or major property damage if ignored.

**⚠ WARNING** warns about hazards that **can** cause death, serious personal injury, or major property damage if ignored.

**⚠ CAUTION** warns about hazards that **will** or **can** cause minor personal injury or property damage if ignored.

**NOTICE** indicates special instructions not related to hazards.

**Carefully read and follow all safety instructions in this manual and on equipment.** Keep safety labels in good condition; replace if missing or damaged.

**⚠ WARNING** **Hazardous pressure** **Incorrectly installed or tested equipment may fail, causing severe injury or property damage.** Read and follow instructions in owner's manual when installing and operating equipment. Have a trained pool professional perform all pressure tests.

1. Do not connect system to a high pressure or city water system.
2. Use equipment only in a pool or spa installation.
3. Install pump with at least 2 hydraulically balanced main drains equipped with correctly installed, screw-fastened, anti-entrapment certified covers. See Page 4.
4. Trapped air in system can cause explosion. **BE SURE** all air is out of system before operating or testing equipment.

**Before pressure testing, make the following safety checks:**

- Check all clamps, bolts, lids, and system accessories before testing.
- Release all air in system before testing.
- Tighten Sta-Rite trap lids to 30 ft. lbs. (4.1 kg-m) torque for testing.
- Water pressure for test must be less than 25 PSI (7.5 kg/cm<sup>2</sup>).
- Water Temperature for test must be less than 100° F (38° C).
- Limit test to 24 hours. After test, visually check system to be sure it is ready for operation. Remove trap lid and retighten hand tight only.

**NOTICE:** These parameters apply to Sta-Rite equipment only. For non-Sta-Rite equipment, consult manufacturer.

## IMPORTANT SAFETY INSTRUCTIONS

Always follow basic safety precautions with this equipment, including the following.

**▲ WARNING** To reduce the risk of injury, do not permit children to use this product unless they are closely supervised at all times.

**▲ CAUTION** This pump is for use with permanently installed pools and may also be used with hot tubs and spas if so marked. Do not use with storable pools. A permanently installed pool is constructed in or on the ground or in a building such that it cannot be readily disassembled for storage. A storable pool is constructed so that it may be readily disassembled for storage and reassembled to its original integrity.

## SAVE THESE INSTRUCTIONS

## INSTALLATION

**Only qualified, licensed personnel should install pump and wiring.**

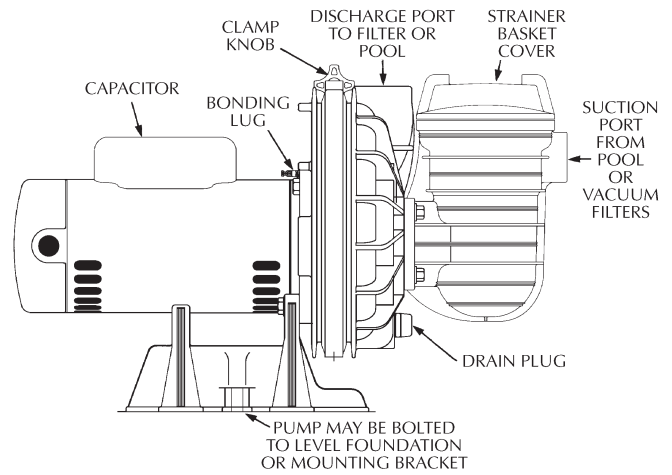

**Figure 1**

### Pump mount must:

Be located away from corrosive or flammable chemicals. Have enough ventilation to maintain air temperature at less than the maximum ambient temperature rating (Max. Amb.) listed on the motor model plate. If this pump is installed in an enclosure/pump house, the enclosure must have adequate ventilation and air circulation to keep the temperature in the enclosure at or below the motor's rated ambient temperature whenever the pump is running.

Be solid - Level - Rigid - Vibration free - Non-combustible. (To reduce vibration and pipe stress, bolt pump to mount.)

Allow pump suction inlet height to be as close to water level as possible.

Allow use of short, direct suction pipe (To reduce friction losses).

Allow for gate valves in suction and discharge piping.

Have adequate floor drainage to prevent flooding.

Be protected from excess moisture.

Allow adequate access for servicing pump and piping.

**▲ WARNING** **Fire and burn hazard.** Modern motors run at high temperatures. To reduce the risk of fire, do not allow leaves, debris, or foreign matter to collect around the pump motor. To avoid burns when handling the motor, let it cool for 20 minutes before trying to work on it.

**NOTICE:** Use Teflon tape or Plasto-Joint Stik<sup>1</sup> for making all threaded connections to the pump. Do not use pipe dope; pipe dope will cause stress cracking in the pump.

**NOTICE:** Pump suction and discharge connections have molded in thread stops. DO NOT try to screw pipe in beyond these stops.

<sup>1</sup>Lake Chemical Co., Chicago, Illinois

## Teflon Taping Instructions:

Use only new or clean PVC pipe fittings.

Wrap male pipe threads with one to two layers of Teflon tape. Cover entire threaded portion of pipe.

**Do not** overtighten or tighten past thread stop in pump port! If leaks occur, remove pipe, clean off old tape, rewrap with one to two additional layers of tape and remake the connection.

**NOTICE:** Support all piping connected with pump!

## Piping:

Use at least 1-1/2" IPS PVC pipe with 5" (127mm) trap. Use at least 2" pipe with 6" (152mm) trap. Increase size if a long run is needed.

To avoid strains on the pump, support both suction and discharge pipes independently. Place these supports near the pump.

To avoid a strain left by a gap at the last connection, start all piping at the pump and run pipe **away** from the pump. Never use a suction pipe smaller than pump suction connection. To avoid airlocking, slope suction pipe slightly upward toward the pump.

**NOTICE:** To prevent flooding when removing pump for service, all flooded suction systems **must** have gate valves in suction and discharge pipes.

## Fittings:

Fittings restrict flow; for best efficiency use fewest possible fittings.

Avoid fittings which could cause an air trap.

Pool fittings must conform to International Association of Plumbing and Mechanical Officials (IAPMO) standards.

To reduce risk of suction entrapment, do not exceed the rated flow rate of the suction fittings.

## POOL PUMP SUCTION REQUIREMENTS

**▲WARNING** Pump suction is hazardous and can trap and drown or disembowel bathers. Do not use or operate swimming pools, spas, or hot tubs if a suction outlet cover is missing, broken, or loose. Follow the guidelines below for a pump installation which minimizes risk to users of pools, spas, and hot tubs.

### Entrapment Protection

The pump suction system *must* provide protection against the hazard of suction entrapment or hair entrapment/entanglement.

### Suction Outlet Covers

All suction outlet covers must be maintained. They must be replaced if cracked, broken, or missing.

See below for outlet cover certification requirements.

All suction outlets must have correctly installed, screw-fastened covers in place.

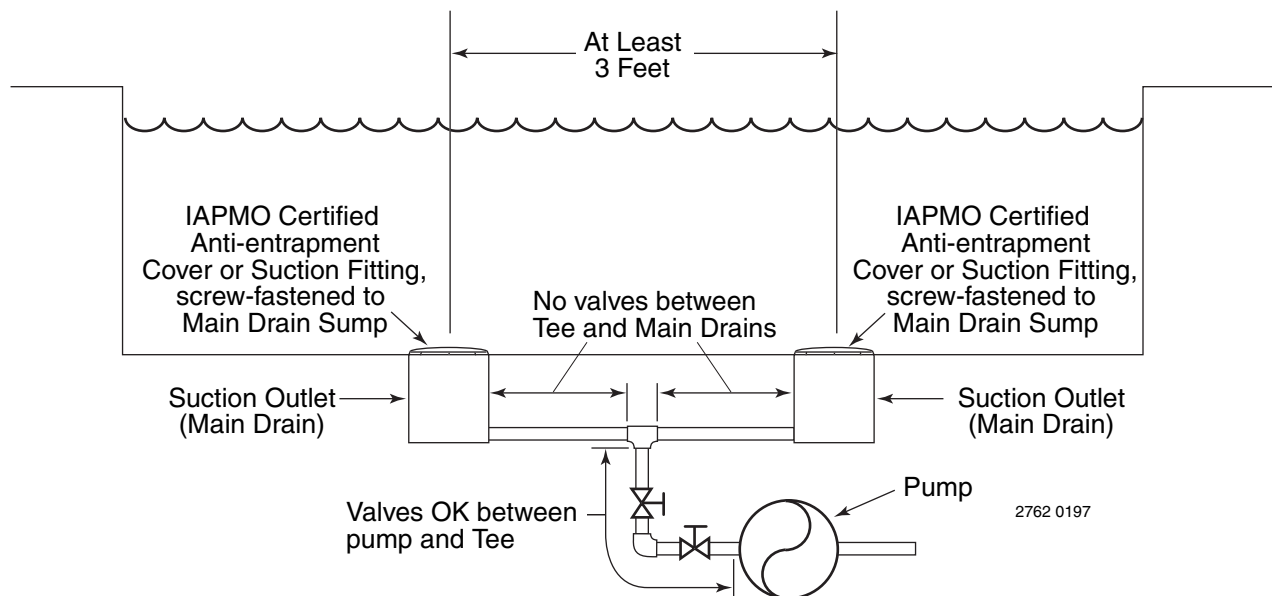

Figure 2 – Recommended pump suction layout.

## Testing and Certification

Suction outlet covers must have been tested by a nationally recognized testing laboratory and found to comply with the latest ASME/ANSI Specification for *Suction Fittings For Use in Swimming Pools, Spas, Hot Tubs, and Whirlpool Bathtub Applications*.

## Outlets Per Pump

Provide at least two hydraulically balanced main drains, with covers (see Page 4), for each swimming pool pump suction line. The centers of the main drains (suction fittings) must be at least three feet apart.

The system must be built so that it cannot operate with the pump drawing water from only *one* main drain (that is, there must be at least two main drains connected to the pump whenever it is running). (See Figure 2).

However, if two main drains run into a single suction line, the single suction line may be equipped with a valve which will shutoff *both* main drains from the pump (see Figure 2).

More than one pump can be connected to a single suction line as long as the requirements above are met.

## Water Velocity

The maximum water velocity through any suction outlet must be 1.5 feet per second unless the outlet complies with the latest ASME/SNSI Specification for *Suction Fittings For Use in Swimming Pools, Spas, Hot Tubs, and Whirlpool Bathtub Applications*. In any case, do not exceed the suction fittings maximum designed flow rate.

If 100% of the pump's flow comes from the main drain system, the maximum water velocity in the pump suction hydraulic system must be six feet per second or less even if one main drain (suction fitting) is completely blocked. The flow through the remaining main drain(s) must comply with the latest ASME/ANSI Specification for *Suction Fittings For Use in Swimming Pools, Spas, Hot Tubs, and Whirlpool Bathtub Applications*.

## ELECTRICAL

### ⚠ WARNING



**Hazardous voltage. Can shock, burn, or cause death.**

Ground pump before connecting to power supply.

⚠ Ground motor before connecting to electrical power supply. Failure to ground motor can cause severe or fatal electrical shock hazard.

⚠ Do not ground to a gas supply line.

⚠ To avoid dangerous or fatal electrical shock, turn OFF power to motor before working on electrical connections.

⚠ Ground Fault Circuit Interrupter (GFCI) tripping indicates an electrical problem. If GFCI trips and

will not reset, have a qualified electrician inspect and repair electrical system.

⚠ Exactly match supply voltage to nameplate voltage. Incorrect voltage can cause fire or seriously damage motor and voids warranty. If in doubt consult a licensed electrician.

## Voltage

Voltage at motor must be not more than 10% above or below motor nameplate rated voltage or motor may overheat, causing overload tripping and reduced component life. If voltage is less than 90% or more than 110% of rated voltage when motor is running at full load, consult power company.

## Grounding/Bonding

Install, ground, bond and wire motor according to local or National Electrical Code requirements.

Permanently ground motor. Use green ground terminal provided under motor canopy or access plate (See Fig. 3); use size and type wire required by code. Connect motor ground terminal to electrical service ground.

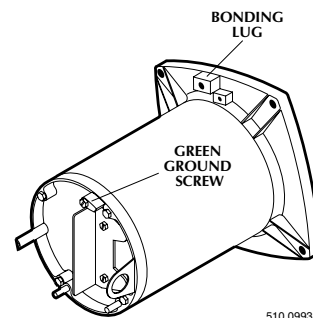

Figure 3 – Typical ground screw and bonding lug locations.

Ground wire must be a copper conductor. It should be the same size as the current-carrying wires to the motor, but not smaller than No. 12 AWG.

Bond motor to pool structure. Use a solid copper conductor, size No. 8 AWG (8.4 sq. mm) or larger. Run wire from external bonding lug (see Fig. 3) to reinforcing rod or mesh.

Connect a No. 8 AWG (8.4 sq. mm) solid copper bonding wire to the pressure wire connector provided on the motor housing and to all metal parts of the swimming pool, spa, or hot tub and to all electrical equipment, metal piping or conduit within 5 feet (1.5 m) of the inside walls of swimming pool, spa, or hot tub.

## Wiring

**NOTICE:** For 575 volt models, consult a licensed electrician.

**NOTICE:** 3 phase models require magnetic motor starters and external overload protection. If in doubt about the procedure, consult a licensed electrician.

Pump must be permanently connected to circuit. See Figures 4A, and 4B for wiring connection diagrams. See Table I, Page 8, for correct wire and circuit breaker sizes for the pump alone. If other lights or appliances are also on the same circuit, be sure to add their amp loads to pump amp load before figuring wire and circuit breaker sizes. (If unsure how to do this or if this is confusing, consult a licensed electrician.) Use the load circuit breaker as the master on-off switch.

Install a Ground Fault Circuit Interrupter (GFCI) in circuit; it will sense a short-circuit to ground and disconnect power before it becomes dangerous to pool users. For size of GFCI required and test procedures for GFCI, see manufacturer's instruction.

In case of power outage, check GFCI for tripping (which will prevent normal pump operation). Reset if necessary.

**⚠ WARNING** Risk of dangerous or fatal electrical shock.

**Be sure that power to the motor circuit is off before working on wiring, wiring connections, or motor. Re-install the motor end cover and all other wiring covers before turning on the power.**

## Motor Switch Settings

Dual-voltage motors (motors that can operate at either 115 or 230 volts), are set at the factory to 230 volts. Do not change motor voltage setting if line voltage is 230 volts, or if you have a single voltage motor.

**NOTE:** Never wire a 115 volt motor to a 230 volt line.

## Remove Motor End Cover

If you have a dual-voltage motor, and will connect it to 115 volts, follow the procedure below.

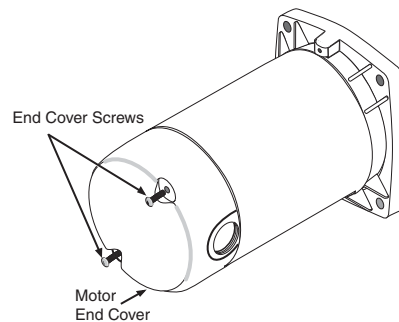
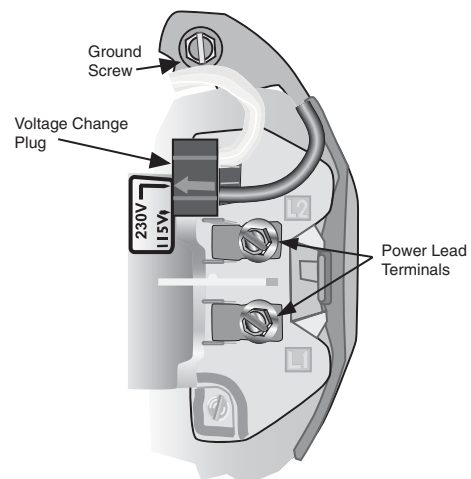

**Figure 4 - Removing motor end cover.**

You will need to remove the motor end cover to change the voltage setting.

Your motor terminal board (located under the motor end cover) should look like one of those below.

## Plug Type Voltage Selector



**Figure 5 – Voltage set to 230 volts, Plug Type.**

To change to 115 volts:

1. Make sure power is off.
2. Pull the plug straight up.
3. Move and attach the plug at the 115 volt position. The plug will now cover 2 metal tabs. The arrow on the plug will point to 115V.
4. Attach the power lead wires to the power lead terminals. Make sure the wires are secure.
5. Attach the ground wire to the green ground screw
6. Reinstall the Motor end cover



## Dial Type Voltage Selector

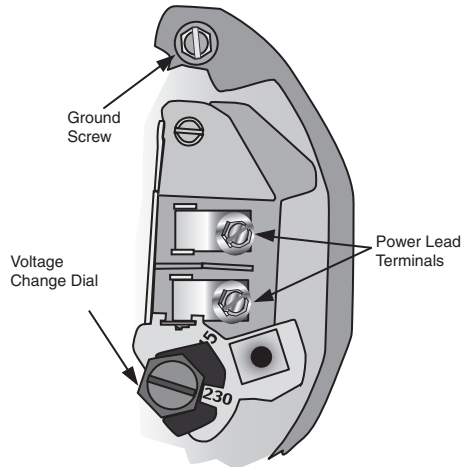

Figure 6 – Voltage set to 230 volts, Dial Type.

To change to 115 volts:

1. Make sure power is off.
2. Turn the dial counter-clockwise until 115 shows in the dial window.
3. Attach the power lead wires to the power lead terminals. Make sure the wires are secure.
4. Attach the ground wire to the green ground screw
5. Reinstall the Motor end cover

## To Wire a Two-Speed Motor

Wire the pump as shown in the diagram.

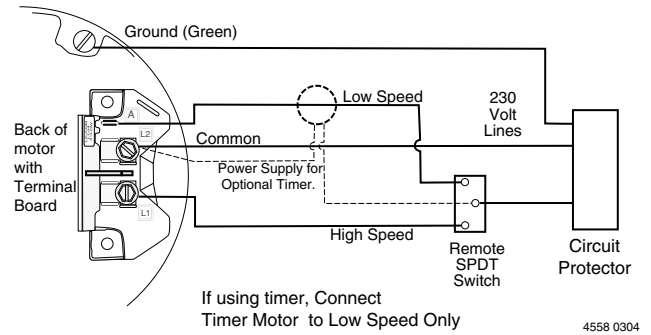

Minimum switch and timer amp rating must equal Branch Fuse Rating given in "Recommended Fusing and Wiring Data" table.

Figure 7 – 2-Speed motor wiring diagram.

**TABLE I – ELECTRICAL DATA - FUSING AND WIRING REQUIREMENTS**

**Dura-Glas I and Max-E-Glas I Pool Pumps**

**Single-Speed Models**

Model	Motor HP	Voltage/Hz/Phase	Max Load Amps	Branch Fuse Rating Amps*	Serv. to Motor - Dist. in Ft. (M)		
					0-100' (0-30M)	101-200' (30-60M)	201-300' (60-90M)
PE52C-180L	1/2	100/200/60/1	12.0/6.0	15/15	14/14(2/2)	10/14(5.5/2)	8/12(8.4/3)
PE5C-180L	1/2	115/230/60/1	9.6/4.8	15/15	14/14(2/2)	10/14(5.5/2)	10/14(5.5/2)
P2R5C-180L	1/2	115/230/60/1	13.4/6.7	20/15	12/14(2/3)	10/14(5.5/2)	8/14(8.4/2)
P2RA5C-179L	1/2	230/60/1	9.9/5.0	15/15	14/14(2/2)	12/14(3/2)	8/14(8.4/2)
PE52D-181L	3/4	100/200/60/1	13.4/6.7	20/15	12/14(3/2)	10/14(5.5/2)	8/14(8.4/2)
PE5D-181L	3/4	115/230/60/1	13.8/6.9	20/15	12/14(3/2)	10/14(5.5/2)	8/14(8.4/2)
PEA5D-180L	3/4	115/230/60/1	11.0/5.5	15/15	14/14(2/2)	10/14(5.5/2)	8/14(8.4/2)
PEAXSSD-180	3/4	115/230/60/1	9.6/4.8	15/15	14/14(2/3)	10/14(5.5/2)	10/14(5.5/2)
P2R5D-181L	3/4	115/230/60/1	15.3/7.6	20/15	12/14(3/2)	8/14(8.4/2)	6/14(14/2)
P2RA5D-180L	3/4	115/230/60/1	13.4/6.7	20/15	12/14(3/2)	10/14(5.5/2)	8/14(8.4/2)
71532	3/4	115/230/60/1	13.4/6.7	20/15	12/14(3/2)	10/14(5.5/2)	8/14(8.4/2)
PE52E-182L	1	200/60/1	8.5	15	14(2)	14(2)	12(3)
PE5E-182L	1	115/230/60/1	16.0/8.0	25/15	12/14(3/2)	8/14(8.4/2)	6/12(14/3)
PEA5E-181L	1	115/230/60/1	13.8/6.9	20/15	12/14(3/2)	10/14(5.5/2)	8/12(8.4/2)
PEAXSSE-181	1	115/230/60/1	12.6/6.3	20/15	12/14(3/2)	10/14(5.5/2)	8/14(8.4/2)
P2FA5E-180L	1	115/230/60/1	13.4/6.7	20/15	12/14(3/2)	10/14(5.5/2)	8/14(8.4/2)
P2R5E-182L	1	115/230/60/1	18.2/9.1	30/15	10/14(5.5/2)	8/14(8.4/2)	6/12(14/3)
P2RA5E-181L	1	115/230/60/1	15.3/7.6	20/15	12/14(3/2)	8/14(8.4/2)	6/14(14/2)
71808	1	115/230/60/1	15.3/7.6	20/15	12/14(3/2)	8/14(8.4/2)	6/14(14/2)
PEA5F-182L	1-1/2	115/230/60/1	16.0/8.0	30/15	12/14(3/2)	8/14(8.4/2)	6/14(14/2)
PEA6F-182L	1-1/2	115/230/60/1	16.0/8.0	30/15	12/14(3/2)	8/14(8.4/2)	6/14(14/2)
PEAXSSF-182	1-1/2	115/230/60/1	16.0/8.0	30/15	12/14(3/2)	8/14(8.4/2)	6/14(14/2)
P2FA5F-181L	1-1/2	115/230/60/1	15.3/7.6	20/15	12/14(3/2)	8/14(8.4/2)	6/14(14/2)
P2RA5F-182L	1-1/2	115/230/60/1	18.2/9.1	30	10/14(5.5/2)	8/14(8.4/2)	6/12(14/3)
PE52F-183L	1-1/2	200/60/1	10.5	15	14(2)	12(3)	12(3)
PEAXSSG-183	2	230/60/1	10.4	15	14(2)	14(2)	12(3)
P2RA6G-183L	2	230/60/1	12.0	20	14(2)	14(2)	12(3)
P2RAXG-183LS	2	230/60/1	12.0	20	14(2)	14(2)	12(3)
PEAAXSSG-184	2-1/2	230/60/1	11.2	20	14(2)	14(2)	12(3)
PE6H-185L, LC	3	230/60/1	15.8	25	12(3)	12(3)	10(5.5)

**Two-Speed Models**

Model	Motor HP	Voltage/Hz/Phase	Max Load Amps	Branch Fuse Rating Amps*	Serv. to Motor - Dist. in Ft. (M)		
					0-100' (0-30M)	101-200' (30-60M)	201-300' (60-90M)
PEXYD-194L	3/4-1/8	115/60/1	12.0/4.0	15	14(2)	10(5)	8(8.4)
PEAXYE-181L	1-1/6	230/60/1	5.3/2.0	15	14(2)	14(2)	14(2)
P2RA5YE-181L, LC	1-1/6	230/60/1	7.3/2.6	15	14(2)	14(2)	14(2)
P2RA5YE-194L	1-1/6	115/60/1	14.5/5.0	20	12(3)	8(8.4)	6(14)
P2RA5YF-182L	1-1/2-1/4	230/60/1	9.2/2.5	15	14(2)	14(2)	12(3)
P2RA5YF-196L	1-1/2-1/4	115/60/1	18.7/5.1	25	10(5)	8(8.4)	6(14)
P2RA6YF-182L	1-1/2-1/4	115/60/1	18.7/5.1	25	10(5)	8(8.4)	6(14)
PEAXYG-183L	2-1/3	230/60/1	10.1/3.7	15	14(2)	14(2)	12(3)
PEAXYG-183LS	2-1/3	230/60/1	10.1/3.7	15	14(2)	14(2)	12(3)
P2RA5YG-183L	2-1/3	230/60/1	10.1/3.7	15	14(2)	14(2)	12(3)

**Three Phase Models**

Model	Motor HP	Voltage/Hz/Phase	Max Load Amps	Branch Fuse Rating Amps*	Serv. to Motor - Dist. in Ft. (M)		
					0-100' (0-30M)	101-200' (30-60M)	201-300' (60-90M)
P2RA5C3-179	1/2	208-230/460/60/3	2.3/1.15	15/15	14/14(2/2)	14/14(2/2)	14/14(2/2)
P2R5D3-181	3/4	230/460/60/3	3.6	15	14/14(2/2)	14/14(2/2)	14/14(2/2)
P2R52D3-181	3/4	200/400/60/3	3.8/1.9	15/15	14/14(2/2)	14/14(2/2)	14/14(2/2)
P2R5E3-182	1	230/460/60/3	4.7	15	14/14(2/2)	14/14(2/2)	14/14(2/2)
P2R52E3-182	1	200/400/60/3	5.6/2.8	15/15	14/14(2/2)	14/14(2/2)	14/14(2/2)
P2R5F3-183	1-1/2	230/460/60/3	5.8	15	14/14(2/2)	14/14(2/2)	14/14(2/2)
P2R52F3-183	1-1/2	200/400/60/3	6.6/3.3	15/15	14/14(2/2)	14/14(2/2)	14/14(2/2)
P2R5G3-184	2	230/460/60/3	7.0	15	14/14(2/2)	14/14(2/2)	14/14(2/2)
P2R52G3-184	2	200/400/60/3	8.0/4.0	15/15	14/14(2/2)	14/14(2/2)	14/14(2/2)
PE6H3-185	3	230/460/60/3	9.7/4.9	15/15	14/14(2/2)	14/14(2/2)	12/14(3/2)

**NOTICE:** For 575 volt models, consult a licensed electrician.



## OPERATION

**NOTICE:** NEVER run pump dry. Running pump dry may damage seals, causing leakage and flooding. Fill pump with water before starting motor.

**NOTICE:** Maximum ambient temperature for motor operation must not exceed maximum ambient temperature rating on motor model plate.

**CAUTION** Before removing trap cover:

1. **STOP PUMP** before proceeding.
2. **CLOSE GATE VALVES** in suction and discharge pipes.
3. **RELEASE ALL PRESSURE** from pump and piping system.
4. **NEVER tighten or loosen clamp while pump is operating.**

**WARNING** If pump is being pressure tested, release all pressure before removing trap cover.

**WARNING**



**Hazardous suction. Can trap hair or body parts, causing severe injury or death.**

Do not block suction.

**WARNING** Do not block pump suction. To do so with body may cause severe or fatal injury. Small children using pool must ALWAYS have close adult supervision.

**WARNING** Fire and burn hazard. Modern motors run at high temperatures. To reduce the risk of fire, do not allow leaves, debris, or foreign matter to collect around the pump motor. To avoid burns when handling the motor, let it cool for 20 minutes before trying to work on it. An automatic in-

ternal cutoff switch protects single phase motors from heat damage during operation.

### Priming Pump

Release all pressure from filter, pump, and piping system; see the filter owner's manual.

In a flooded suction system (water source higher than pump), pump will prime itself when suction and discharge valves are opened.

If pump is not in a flooded suction system, unscrew and remove trap cover; fill trap and pump with water.

Do not lubricate the trap cover O-Ring. The original equipment O-Ring contains a permanent internal lubricant.

**NOTICE:** If you replace the O-Ring with a non-internally lubricated O-Ring, you may need to apply a silicone based lubricant.

Clean and inspect O-Ring; reinstall on trap cover.

Replace trap cover on trap; turn clockwise to tighten cover.

**NOTICE:** Tighten trap cover by hand only (**no wrenches**)! Pump should prime now. Priming time will depend on vertical length of suction lift and horizontal length of suction piping.

If pump does not prime, make sure that all valves are open, suction pipe end is under water, pump suction is below water level, and that there are no leaks in suction pipe. See Troubleshooting Guide, Page 12.

### Routine Maintenance

The only routine maintenance needed is inspection/cleaning of trap basket. Debris or trash that collects in basket will choke off water flow through the pump. Follow instructions below to clean trap:

1. Stop pump, close valves in suction and discharge, and **release all pressure from system before proceeding.**
2. Unscrew trap lid (turn counterclockwise). If necessary, use a lever such as a board or long screwdriver between lugs on trap cover.
3. Remove strainer basket and clean. Be sure all holes in basket are clear, flush basket with water and replace in trap.
4. Clean and inspect "O" Ring; reinstall on trap cover.
5. Clean "O" Ring groove on trap body and replace lid. To help keep lid from sticking, tighten **hand tight only (no wrenches!)**.
6. Prime pump (see priming instructions, above).

### Draining Pump

**WARNING**



**Hazardous voltage. Can shock, burn, or cause death.**

Disconnect power before working on pump or motor.

1. Pump down water level below all inlets to the pool.

**WARNING** To avoid dangerous or fatal electrical shock hazard, turn OFF power to motor before draining pump.

2. To prevent pump from freezing, remove the trap cover and drain the tank body through the drain plug (Key No. 15, Page 13). Clean pump thoroughly; replace trap cover.

**NOTICE:** Tighten trap cover by hand only (**no wrenches**)! Use a lever or wrench only if necessary to remove cover! If pump is not anchored, use caution to not break attached piping!

3. Use Sta-Rite U79-11 Lid Wrench to remove trap covers that have been overtightened or have taken a set and cannot be removed by hand. Lugs have been provided on the trap lid to use a lever or pry bar for loosening.

4. Cap inlet piping after draining to keep water out of the pipes.
5. Be sure motor is kept dry and covered.

### Storage/Winterizing:

**▲ WARNING** Explosion hazard. Purging the system with compressed air can cause components to explode, with risk of severe injury or death to anyone nearby. Use only a low pressure (below 5 PSI), high volume blower when air purging the pump, filter, or piping.

**▲ CAUTION** Pool chemicals may give off corrosive fumes. Store chemicals away from pump in a well ventilated area.

**NOTICE:** Allowing pump to freeze will damage pump and void warranty!

**NOTICE: Do not** use anti-freeze solutions (except propylene glycol) in your pool/spa system. Propylene glycol is non-toxic and will not damage plastic system components; other anti-freezes are highly toxic and may also damage plastic components in the system.

Drain all water from pump and piping when expecting freezing temperatures or when storing pump for a long time (see instructions below).

Keep motor dry and covered during storage.

To avoid condensation/corrosion problems, **do not** cover pump with plastic.

For outdoor/unprotected installations:

1. Gravity drain system as far as possible.
2. Protect areas which retain water with non-toxic propylene glycol antifreeze ("RV antifreeze").
3. Enclose entire system in a weatherproof enclosure.
4. To avoid condensation/corrosion damage, allow ventilation; do not wrap system in plastic.
5. Use a 40% propylene glycol/60% water solution to protect pump to -50 degrees F (-46 degrees C).

### Startup For Winterized Equipment

1. Remove any temporary weather protection placed around system.
2. Follow filter manufacturer's instructions for reactivation of the filter.
3. Inspect all electrical wiring for damage or deterioration over the shutdown period. Have a qualified service-man repair wiring as needed.
4. Inspect and tighten all watertight connections.
5. Open all valves in suction and return piping.
6. Remove any winterizing plugs in piping system.
7. Drain all antifreeze from system.
8. Close all drain valves and replace all drain plugs in piping system.
9. Prime pump according to instructions on Page 9.

## PUMP SERVICE

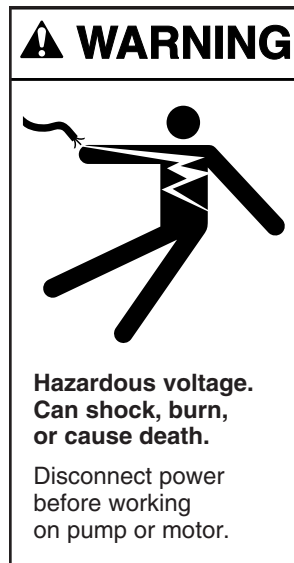

Pump should only be serviced by qualified personnel.

For best results, use only genuine Sta-Rite factory parts.

Be sure to prime pump (Page 9) before starting.

**▲** Before removing trap cover:

1. STOP PUMP before proceeding.
2. CLOSE GATE VALVES in suction and discharge pipes.
3. RELEASE ALL PRESSURE from pump and piping system.
4. NEVER tighten or loosen clamp while pump is operating.

**▲** To avoid dangerous or fatal electrical shock hazard, turn OFF power to motor before working on pump or motor.

Aside from lubricating trap cover O-Ring, no lubrication or regular maintenance is needed beyond reasonable care and periodic cleaning.

If shaft seal is worn or damaged, repair as follows:

### Pump Disassembly/Removing Old Seal

**Disconnect power to pump motor.**

**▲** Be sure gate valves on suction and return piping are closed before starting work.

Release all pressure by opening all vents before starting work.

1. Drain pump by removing drain plugs on bottom of pump body and trap body.
2. After making sure that there is no pressure in trap body, remove cover (unscrew by turning counterclockwise).
3. Remove clamp holding pump halves together.
4. Remove pump base mounting bolts, if used. Motor and seal plate assembly can now be pulled away from pump body.
5. Remove five screws and washers holding diffuser to seal plate.

- Remove motor canopy.

**▲WARNING** Capacitor voltage can be dangerous.

Before proceeding, short the capacitor terminals together with a screwdriver **that has an insulated handle**. Being careful not to touch capacitor terminals, loosen capacitor clamp and move capacitor to one side.

- Hold shaft with 7/16" open-end wrench on motor shaft flats.

**NOTICE:** On models with impeller screw, remove impeller screw (left hand thread - turn **clockwise**) and gasket before removing impeller. Inspect gasket for damage, cracks, etc. Replace if damaged.

- Unscrew impeller from shaft (turn counterclockwise when facing it).
- Remove four screws holding seal plate to motor.
- Place seal plate face down on flat surface and tap out ceramic seat (Figure 8).



Figure 8



Figure 9

- Clean seal cavity in seal plate and clean motor shaft.

### Pump Reassembly/Installing New Seal

- Ceramic seat must be clean and free of dirt, grease, dust, etc. Wet outer edge of O-Ring with small amount of liquid detergent; press ceramic seat into seal plate cavity firmly and squarely with finger pressure (Figure 9).

- If ceramic seat will not locate properly, remove it, place **face up** on bench and reclean cavity. Ceramic seat should now locate.

- If seat still will not locate properly, place a cardboard washer over the polished face and use a piece of 3/4" (19mm) standard pipe for pressing purposes.

**NOTICE: Be sure** not to scratch or mar polished surface or seal will leak.

- Remount seal plate on motor. Tighten bolts to 60-80 inch-lbs. (69-92 kg/cm) torque.
- Apply a **small** amount of liquid detergent to inside diameter of rotating half of seal.
- Slide rotating seal member, polished face last, over threaded shaft end and shaft shoulder until rubber drive ring hits shaft shoulder.

**NOTICE: Be sure** not to nick or scratch polished seal face; seal will leak if face is damaged.

- Screw impeller onto shaft (clockwise); this will automatically locate seal in seal plate.

**NOTICE:** On models with impeller screw: install impeller gasket and lock screw (left-hand thread – turn counterclockwise).

- Mount diffuser on seal plate; tighten screws to 10-14 inch-lbs. (11.5-16.1 cent.-kg.) torque.

- Assemble motor and seal plate to volute; be sure clamp is properly seated. **NOTICE:** Clamp knob can be located in any position around volute; if it is moved after assembly, tighten knob while tapping around clamp to assist sealing. Do not move clamp while pump is full of water.

**▲WARNING** Hazardous pressure. Release all pressure from pump and piping system before working on pump or attempting to adjust or remove clamp. Clamp may blow off of pump if adjusted under pressure.

- Reinstall pump base mounting bolts (if used) and prime pump according to instructions on Page 9.

## TROUBLESHOOTING GUIDE

**⚠ Read and understand safety and operating instructions in this manual before doing any work on pump!**

**⚠ Only qualified personnel should electrically test pump motor!**

### FAILURE TO PUMP; REDUCED CAPACITY OR DISCHARGE PRESSURE

#### Suction leaks/lost prime:

1. Pump must be primed; make sure that pump volute and trap are full of water. See priming instructions, Page 9.
2. Make sure there are no leaks in suction piping.
3. Make sure suction pipe inlet is well below the water level to prevent pump from sucking air.
4. If suction trap gasket is defective, replace it.
5. Suction lift of 15 to 25 feet (4.5 to 7.5 meters) will reduce performance. Suction lift of more than 25 feet (7.5 meters) will prevent pumping and cause pump to lose prime. In either case, move pump closure (vertically) to water source. Make sure suction pipe is large enough.

#### Clogged pipe/trap/impeller, worn impeller:

6. Make sure suction trap is not clogged; if it is, clean trap and strainer.
7. Make sure impeller is not clogged (follow steps 1 through 7 under "Removing Old Seal", Page 10; check impeller for clogging; follow steps 7 through 9 under "Installing New Seal", Page 11, for reassembly).
8. Impeller and diffuser may be worn. If so, order replacement parts from Repair Parts List, Pages 13 and 14.
9. Pump may be trying to push too high a column of water. If so, a "higher head" pump is needed.

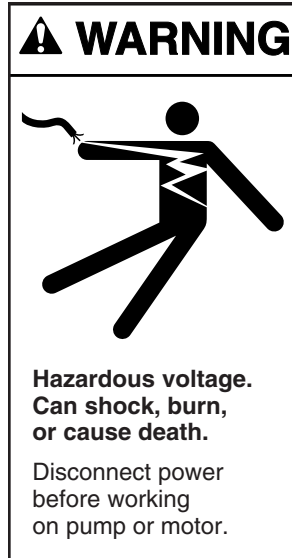

#### Electrical:

10. Pump may be running too slowly; check voltage at motor terminals and at meter while pump is running. If low, see wiring instructions or consult power company. Check for loose connections.
11. Pump may be too hot.
  - A. Check line voltage; if less than 90% or more than 110% of rated voltage consult a licensed electrician.
  - B. Increase ventilation.
  - C. Reduce ambient temperature.

D. Tighten any loose connections.

### MECHANICAL TROUBLES AND NOISE

1. If suction and discharge piping are not adequately supported, pump assembly will be strained. See "Installation", Page 3.
2. Do not mount pump on a wooden platform! Securely mount on concrete platform for quietest performance.

## REPAIR PARTS LIST DURA-GLAS POOL PUMP MAX-E-GLAS POOL PUMP 1/2 through 3 HP Models

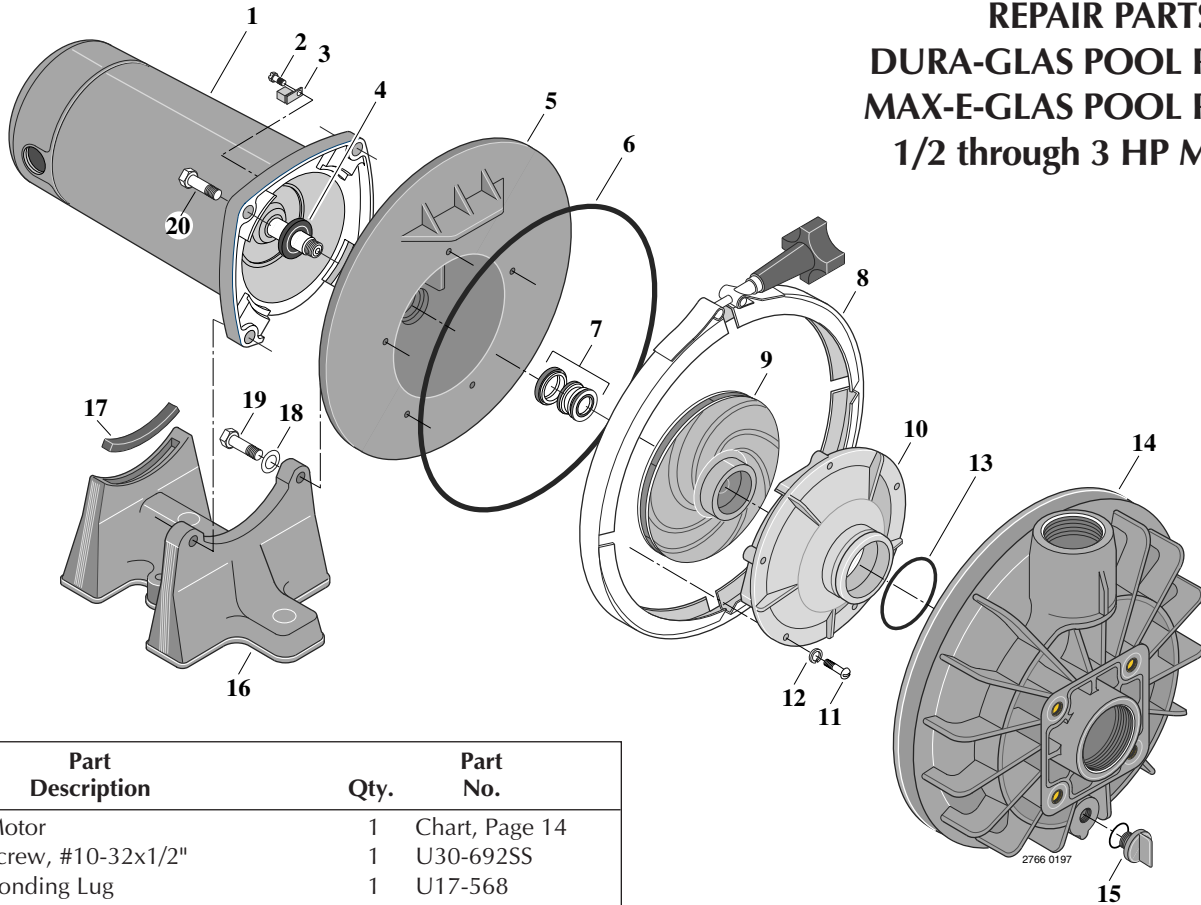

Key No.	Part Description	Qty.	Part No.
1	Motor	1	Chart, Page 14
2	Screw, #10-32x1/2"	1	U30-692SS
3	Bonding Lug	1	U17-568
4	Water Slinger	1	C69-2
5	Seal Plate	1	C203-193P
6	O-Ring	1	U9-228A
7	Shaft Seal	1	17304-0100S
8	Clamp	1	C19-37A
	• Clamp Knob	1	WC36-22
9	Impeller	1	Chart, Page 14
10	Diffuser*	1	Chart, Page 14
11	Screw, #8-32x7/8"	5	U30-542SS
12	Washer, #8 Lock	5	U43-21SS
13	Diffuser O-Ring	1	U9-226
14	Tank Body	1	C176-47P1
15	1/4" NPT Drain Plug	1	U178-920P
16	Base w/Motor Pad*	1	C104-42P
17	Motor Pad*	1	C35-11
18	Washer, Flat	2	U43-42SS
19	Screw, 3/8-16x1-3/4" Hex Hd.**	2	U30-77SS
20	Screw, 3/8-16x1" Hex Hd.***	2	U30-74SS
	• Reducer 2"x1-1/2"	1	C78-7P
	• Decal "IMPORTANT-Do not use pipe dope..."		WC27-27
	• Motor Nameplate	1	32155-7117
	• Tag, "CAUTION"		61002-0002
	• Tag, "WARNING"		61002-0012
	• Tag, "CAUTION, WARNING (bonding)"		C63-12
	• Nameplate		U33-121

PE5, PE52, P2R5, P2RA5, and P2R52 models include 5" trap, Pkg. 115.

PE6 and P2RA6 models include 6" trap, Pkg. 161.

PEX, PEAX, P2RX and P2RAX models do not include trap. To meet NSF Standard 50 requirements, these pumps must be installed with an NSF listed hair and lint strainer.

For trap parts, see Page 15.

• Not illustrated.

\* Models with "LS" suffix use Steel Base, Part No. J104-9C, and Motor Pad Part No. C35-5.

\*\* Not used on models with "LS" suffix.

\*\*\* Models with "LS" suffix use 4 3/8x16x1" Capscrews Part No. U30-74SS.



## Variable Parts List *(All other parts are common to all models)*

### Dura-Glas I and Max-E-Glas I Pool Pumps

#### SINGLE SPEED MODELS

Model	HP	Volts/Hz/Ph	Motor	Impeller	Diffuser
PE5C-180L	1/2	115/230/60/1	AE100CHL	C105-92PS	C1-216P
PE52C-180L	1/2	100/200/60/1	AE100CH2	C105-92PS	C1-216P
P2R5C-180L	1/2	115/230/60/1	A100CHL	C105-92PS	C1-216P
P2RA5C-179L	1/2	115/230/60/1	A100CLL	C105-92PR	C1-217P1
PE52D-181L	3/4	100/200/60/1	AE100DH2	C105-138PEB	C1-200PA
PE5D-181L	3/4	115/230/60/1	AE100DHL	C105-138PEB	C1-200PA
PEA5D-180L	3/4	115/230/60/1	AE100DLL	C105-92PS	C1-216P
PEAXSSD-180	3/4	115/230/60/1	AE100DLL	C105-92PSC	C1-216PB
P2R5D-181L	3/4	115/230/60/1	A100DHL	C105-138PEB	C1-200PA
P2RA5D-180L	3/4	115/230/60/1	A100DLL	C105-92PS	C1-216P
71532	3/4	115/230/60/1	A100DLL	C105-92PS	C1-216P
PE52E-182L	1	100/200/60/1	AE100EH2	C105-137PEB	C1-200PA
PE5E-182L	1	115/230/60/1	AE100EHL	C105-137PEB	C1-200PA
PEA5E-181L	1	115/230/60/1	AE100ELL	C105-138PEB	C1-200PA
PEAXSSE-181	1	115/230/60/1	AE100ELL	C105-138PEBB	C1-200PAB
P2FA5E-180L	1	115/230/60/1	A100ESLL	C105-92PS	C1-216P
P2R5E-182L	1	115/230/60/1	A100EHL	C105-137PEB	C1-200PA
P2RA5E-181L	1	115/230/60/1	A100ELL	C105-138PEB	C1-200PA
71808	1	115/230/60/1	A100ELL	C105-138PEB	C1-200PA
PEA5F-182L	1-1/2	115/230/60/1	AE100FLL	C105-137PEB	C1-200PA
PEA6F-182L	1-1/2	115/230/60/1	AE100FLL	C105-137PEB	C1-200PA
PEAXSSF-182	1-1/2	115/230/60/1	AE100FLL	C105-137PEB1	C1-200PAB
P2FA5F-181L	1-1/2	115/230/60/1	A100FSLL	C105-138PEB	C1-200PA
P2RAXF-182LS	1-1/2	115/230/60/1	A100FLL	C105-137PEB	C1-200PA
PE52F-183L	1-1/2	200/60/1	AE100FH2	C105-137PDBA	C1-200PA
PEAXSSG-183**	2	230/60/1	AE100GLL	C105-137PDB1A	C1-200PAB
P2RA6G-183L	2	230/60/1	A100GLL	C105-137PDBA	C1-200PA
P2RAXG-183L, LS	2	230/60/1	A100GLL	C105-137PDBA	C1-200PA
PEAAXSSG -184**	2-1/2	230/60/1	AE100G5LL	C105-137PD1A	C1-200PAB
PE6H-185L, LC*	3	230/60/1	AE100HLL	C105-137PKBA	C1-259P

\* Uses one impeller screw, Part No. C30-12.

\*\* Uses one impeller screw, Part No. C30-47.

#### TWO-SPEED MODELS

Model	HP	Volts/Hz/Ph	Motor	Impeller	Diffuser
PEXYD-194L	3/4-1/8	115/60/1	AE100ELL-Y	C105-138PEBA	C1-200PA
PEAXYE-181L	1-1/6	230/60/1	62003-2001	C105-138PEB	C1-200PA
P2RA5YE-181L,LC	1-1/6	230/60/1	A100ELL-Y	C105-138PEB	C1-200PA
P2RA5YE-194L	1-1/6	115/60/1	AE100SLL-Y	C105-138PEB	C1-200PA
P2RA5YF-182L*	1-1/2-1/4	230/60/1	A100FLL-Y	C105-137PEBA	C1-200PA
P2RA6YF-182L	1-1/2-1/4	230/60/1	A100FSLL-Y	C105-137PEBA	C1-200PA
P2RA5YF-196L	1-1/2-1/4	115/60/1	A100FSLL-Y	C105-137PEBA	C1-200PA
PEAXYG-183L	2-1/3	230/60/1	AE100GLL-Y	C105-138PDBA	C1-200PA
P2RA5YG-183L*	2-1/3	230/60/1	AE100GLL-Y	C105-137PDBA	C1-200PA
PEAXYG-183LS	2-1/3	230/60/1	AE100GLL-Y	C105-138PDBA	C1-200PA

\* Uses one impeller screw, Part No. C30-12.

#### THREE-PHASE MODELS

Model	HP	Volts/Hz/Ph	Motor	Impeller	Diffuser
P2RA5C3-179*	1/2	208-230/460/60/3	AP100CL	C105-92PRA	C1-217P
P2R5D3-181*	3/4	208-230/460/60/3	AP100DH	C105-138PEBA	C1-200PA
P2R52D3-181*	3/4	200/400/3	AP100DH2	C105-138PEBA	C1-200PA
P2R5E3-182*	1	208-230/460/60/3	AP100EH	C105-137PEBA	C1-200PA
P2R52E3-181*	1	200/400/3	AP100EH2	C105-137PEBA	C1-200PA
P2R5F3-183*	1-1/2	208-230/460/60/3	AP100FH	C105-137PDBA	C1-200PA
P2R52F3-183*	1-1/2	200/400/3	AP100FH2	C105-137PDBA	C1-200PA
P2RA5F36-182*	1-1/2	575/60/3	62001-1019	C105-137PEBA	C1-200PA
P2R5G3-184*	2	230/460/60/3	AP100GH	C105-137PDA	C1-200PA
P2R52G3-184*	2	200/400/3	AP100GH2	C105-137PDA	C1-200PA
PE5G36-184*	2	575/60/3	62003-2087	C105-137PDBA	C1-200PA
P2RA5G36-183*	2	575/60/3	62003-2087	C105-137PDBA	C1-200PA
PE6H3-185*	3	200-230/460/60/3	AP100HL	C105-137PKBA	C1-200PA

\* Uses one impeller screw, Part No. C30-12.



## 5" TRAP/ADAPTER ASSEMBLY PKG. 115

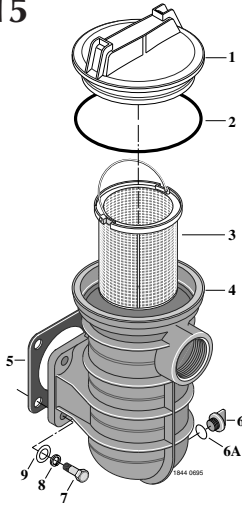

## 6" TRAP/ADAPTER ASSEMBLY PKG. 161

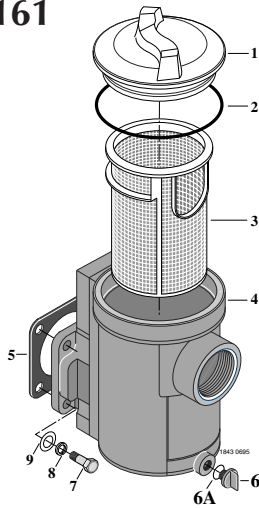

## REPAIR PARTS LIST - 5" and 6" TRAPS\*

Key No.	Part Description	Part No.	
		Pkg. 115 5" Trap	Pkg. 161 6" Trap
1	Trap Cover	C3-139P1	16920-0011
2	O-Ring - Cover	U9-229	16920-0012
3	Strainer Basket	C108-33P	16920-0017
4	Trap Body	C153-53P1	C153-58P
5	Gasket	C20-123	C20-123
6	Pipe Plug - 1/4" NPT (w/O-Ring)	U178-920P	U178-920P
7	Capscrew-5/16-18x1-1/4"	U30-64SS(4)	U30-64SS(4)
8	Washer, Lock 5/16"	U43-11SS(4)	U43-11SS(4)
9	Washer, Flat 5/16"	U43-41SS(4)	U43-41SS(4)

\*Quantity one unless otherwise indicated ( ).

### Overhaul Kits

H.P.	Parts-Pak Number
1/2	PP1011
3/4	PP1014
1	PP1016
1-1/2	PP1018

Kit includes: Impeller, Diffuser, Shaft Seal, Gaskets, O-Rings, Hardware, Shims, Wear Rings and Inserts.

Not available for two and three horsepower PE series pumps.

### Seal/Gasket Kit

Kit includes Shaft Seal, Gaskets, and O-Rings.  
For all horsepower PE series pumps.  
Parts-Pak No. PP1000.

## STA-RITE LIMITED WARRANTY

Pumps, filters, skimmers, underwater lights (excluding bulbs), accessories and fittings manufactured by Sta-Rite are warranted to be free of defects in material and/or workmanship for one (1) year from the original date of installation.

The foregoing warranties relate to the original consumer purchaser ("Purchaser") only. Sta-Rite Industries shall have the option to repair or replace the defective product, at its sole discretion. Purchasers must pay all labor and shipping charges necessary to replace the product covered by this warranty. Requests for warranty service must be made through the installing dealer. This warranty shall not apply to any product that has been subject to negligence, misapplication, improper installation or maintenance, or other circumstances which are not in Sta-Rite's direct control. Failure to have product installed by a professional in compliance with local codes will void any and all manufacturers warranty.

This warranty sets forth Sta-Rite's obligation and Purchaser's exclusive remedy for defective products.

STA-RITE SHALL NOT BE LIABLE FOR ANY CONSEQUENTIAL, INCIDENTAL OR CONTINGENT DAMAGES WHATSOEVER.

THE FOREGOING WARRANTIES ARE EXCLUSIVE AND IN LIEU OF ALL OTHER EXPRESS WARRANTIES. IMPLIED WARRANTIES, INCLUDING BUT NOT LIMITED TO THE IMPLIED WARRANTIES OF MERCHANTABILITY AND FITNESS FOR A PARTICULAR PURPOSE, SHALL NOT EXTEND BEYOND THE DURATION OF THE APPLICABLE EXPRESS WARRANTIES PROVIDED HEREIN.

Some states do not allow the exclusion or limitation of incidental or consequential damages or limitations on how long an implied warranty lasts, so the above limitations or exclusion may not apply to you. This warranty gives you specific legal rights and you may also have other rights which vary from state to state.

Supersedes all previous publications.

### Product Specific Warranties (from date of installation)

Product Family	Limited Warranty	Exceptions
Filters	1 Year	System 3 Tank Bodies - 10 Yrs
Filter Valves	1 Year	
Pumps	1 Year	
Heaters	2 Years	*Commercial Application - 1 Yr
Controls	1 Year	
Above Ground Systems	1 Year	
Lights and Niches	1 Year	Lamps and Bulbs - 90 Days
White Goods	1 Year	
Maintenance Equipment	90 Days	
Drainer/Utility Pumps	90 Days	
Replacement Parts	90 Days	
Cleaners: Lil Shark	1 Year	
Cleaners: Calypso	1 Year	
Cleaners: Pool Shark	2 Years	Footpad and Seal Flaps - 1 Yr
Cleaners: Great White	2 Years	

\* Commercial and multi-family application.

**Retain this warranty certificate in a safe and convenient location for your records.**

For technical information about this product, contact the installer or call Sta-Rite at 262-728-9181.

Visit [www.staritepool.com](http://www.staritepool.com)

- for more information about Sta-Rite products listed above
- to locate a Sta-Rite dealer near you

#### CREATE A RECORD OF YOUR WARRANTY AT STA-RITE:

- Complete a warranty registration at [www.staritepool.com](http://www.staritepool.com) by clicking on "Register Products" and selecting Sta-Rite Pool **OR**
- Complete bottom portion completely and mail within 10 days of installation to Sta-Rite, Attn.: Pool Warranty Dept., 293 Wright St., Delavan, WI 53115



## Warranty Registration Card

Name \_\_\_\_\_

New installation       Replacement

Address \_\_\_\_\_

Years pool has been in service    less than 1    1-3    3-5    5-10

City \_\_\_\_\_ State \_\_\_\_\_ Zip \_\_\_\_\_

**This product was purchased from:**

Installation (or Purchase) Date \_\_\_\_\_

Company name \_\_\_\_\_

Product Purchased \_\_\_\_\_

Address \_\_\_\_\_

Model Number \_\_\_\_\_

City \_\_\_\_\_ State \_\_\_\_\_ Zip \_\_\_\_\_