

**PRODUCT DATA SHEET****MODEL: 8090-511-246****SPECIFICATIONS:****MODEL NUMBER:** 8090-511-246**PUMP DESIGN:** Positive Displacement 3 Chamber Diaphragm Pump**CHECK VALVE:** (2-Way Operation) Prevents Reverse Flow & 6 Ft. Head Forward Flow**CAM:** 2.0 Degree**MOTOR:** Permanent Magnet, P/N 11-160-00, Thermally Protected**VOLTAGE:** 230 VAC Nominal**PRESSURE SWITCH:** Adjustable Shut-Off (Range 40-60 PSI)Factory Set @ 60 PSI, Turn On 45 PSI  $\pm$  5 PSI**LIQUID TEMPERATURE:** 170 Degrees Fahrenheit (77 Degrees Centigrade) Max.**PRIME:** Self-Priming Up To 7 Ft. Vertical,  
Max. Inlet Pressure 30 PSI (2.1 Bar)**PORTS:** 3/8"-18 NPT Female**MATERIAL OF CONSTRUCTION:****PLASTICS-** Polypropylene**VALVES-** Viton**DIAPHRAGM-** Santoprene**FASTENERS-** Zinc Plated Steel**NET WEIGHT:** 3.85 Lbs (1.75 Kg)**DUTY CYCLE:** Intermittent (See Temperature Rise Chart)**TYPICAL APPLICATIONS:** Soil Extraction**APPROVALS:** VDE Approved**DIMENSIONS:**

### TEMPERATURE RISE

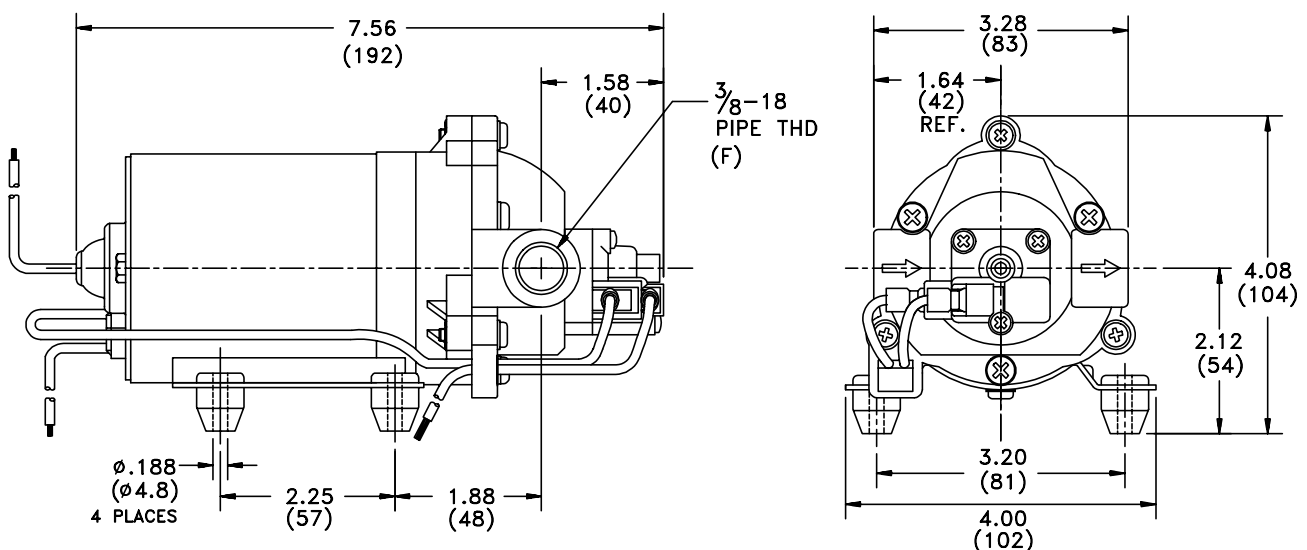
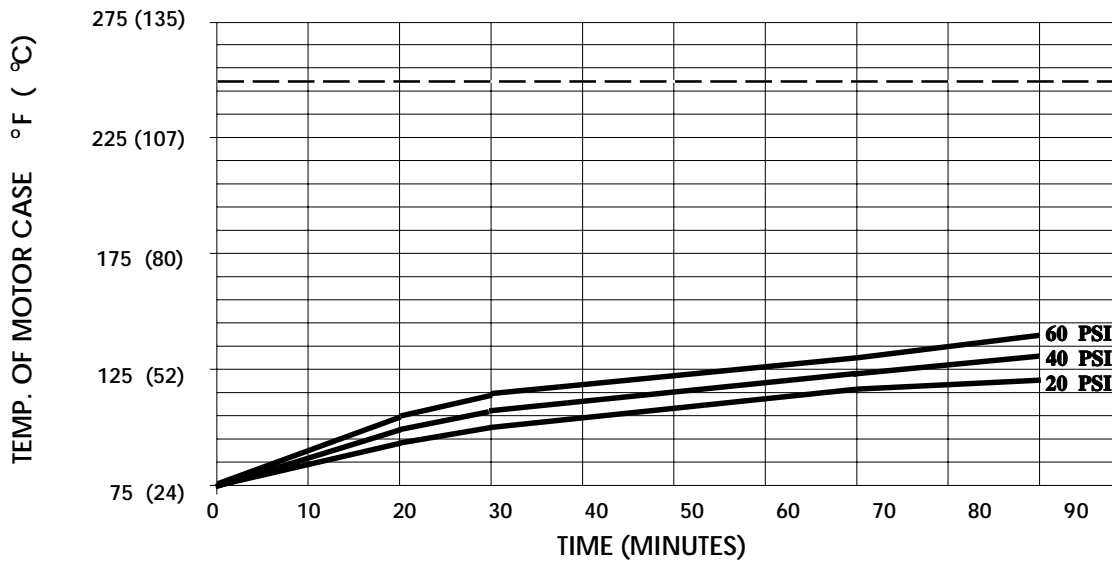

THIS GRAPH IS FOR USE AS A DESIGN GUIDE. IT IS BASED ON RUNNING CONTINUOUSLY WITH AN AMBIENT TEMPERATURE OF 70° F IN STILL AIR. THE THERMAL BREAKER WILL OPEN WHEN THE CASE TEMPERATURE REACHES 250° F.

[----- TRIP POINT OF THERMAL PROTECTOR]

### TYPICAL PERFORMANCE

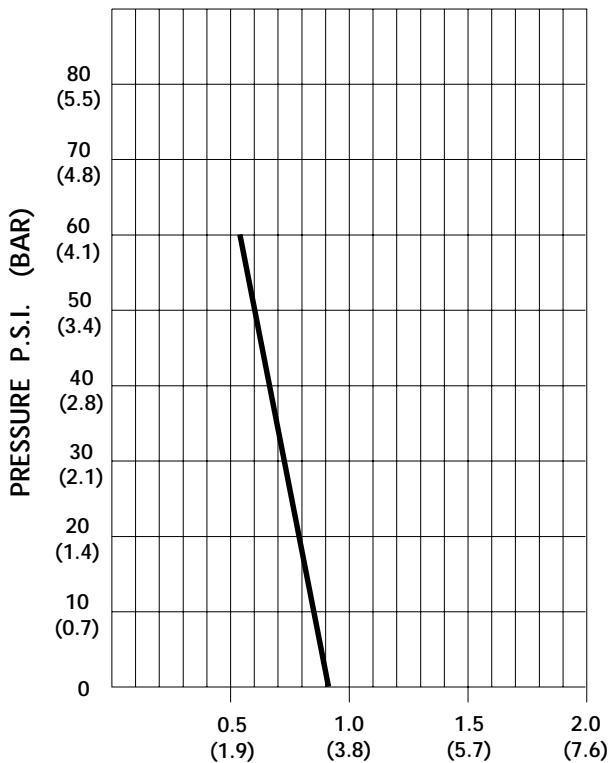

PRESSURE (PSI)	FLOW (GPM/LIT)	RPM MIN/MAX	CURRENT (AMPS)	VOLTAGE (VOLTS)
OPEN	<b>0.91/3.8</b>	<b>2335/2445</b>	<b>.11</b>	<b>230 VAC</b>
10	<b>0.86/3.5</b>	<b>2245/2350</b>	<b>.14</b>	"
20	<b>0.78/3.3</b>	<b>2160/2265</b>	<b>.16</b>	"
30	<b>0.73/3.0</b>	<b>2075/2190</b>	<b>.17</b>	"
40	<b>0.66/2.8</b>	<b>2005/2105</b>	<b>.18</b>	"
50	<b>0.62/3.8</b>	<b>1945/2035</b>	<b>.20</b>	"
60	<b>0.56/1.5</b>	<b>1893/1970</b>	<b>.22</b>	"

FLOW - GALLONS PER MINUTE (LITERS PER MINUTE)

-SPECIFICATIONS SUBJECT TO CHANGE WITHOUT NOTICE.

For technical advice or service please take your pump into your local pump service center.

To order pump or parts or for pricing please go to the following links :

[Shurflo Pumps Home >>](#)

[Shurflo Pumps stock list >>](#)