

SPECIFICATIONS:**MODEL NUMBER:** 8000-813-288**PUMP DESIGN:** Positive Displacement 3 Chamber Diaphragm Pump**CHECK VALVE:** (1-Way Operation) Prevents Reverse Flow**CAM:** 3.0 Degree**MOTOR:** Permanent Magnet, P/N 11-150-10, Thermally Protected**VOLTAGE:** 115 VAC Nominal**PRESSURE SWITCH:** Adjustable Shut-Off (Range 80-100 PSI)Factory Set @100 PSI, Turn On 85 PSI ± 5 PSI**LIQUID TEMPERATURE:** 180 Degrees Fahrenheit (82 Degrees Centigrade) Max.**PRIME:** Self-Priming Up To 12.0 Ft. Vertical,

Max. Inlet Pressure 30 PSI (2.1 Bar)

PORTS: 3/8"-18 NPT, Female**MATERIAL OF CONSTRUCTION:****PLASTICS-** Nylon**VALVES-** Viton**DIAPHRAGM-** Santoprene**FASTENERS-** Zinc Plated Steel**NET WEIGHT:** 4.9 Lbs (2.2 Kg)**DUTY CYCLE:** Intermittent (See Temperature Rise Chart)**APPROVALS:** UL/CSA Recognized**TYPICAL APPLICATIONS:** Soil Extraction**BYPASS:** 80 PSI**DIMENSIONS:**

TEMPERATURE RISE

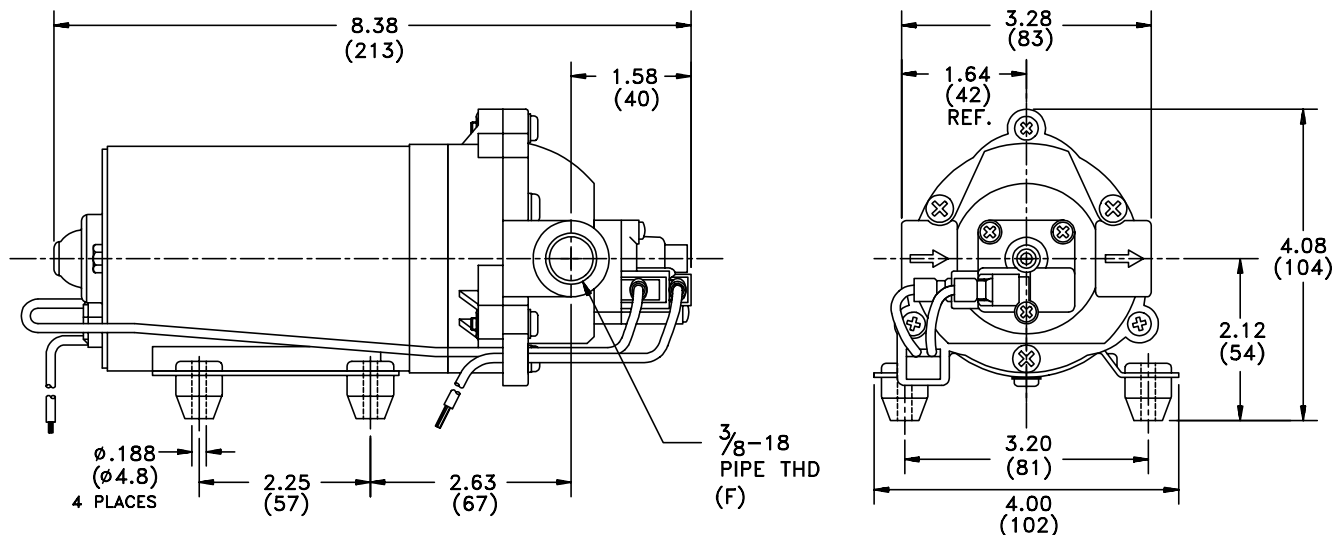
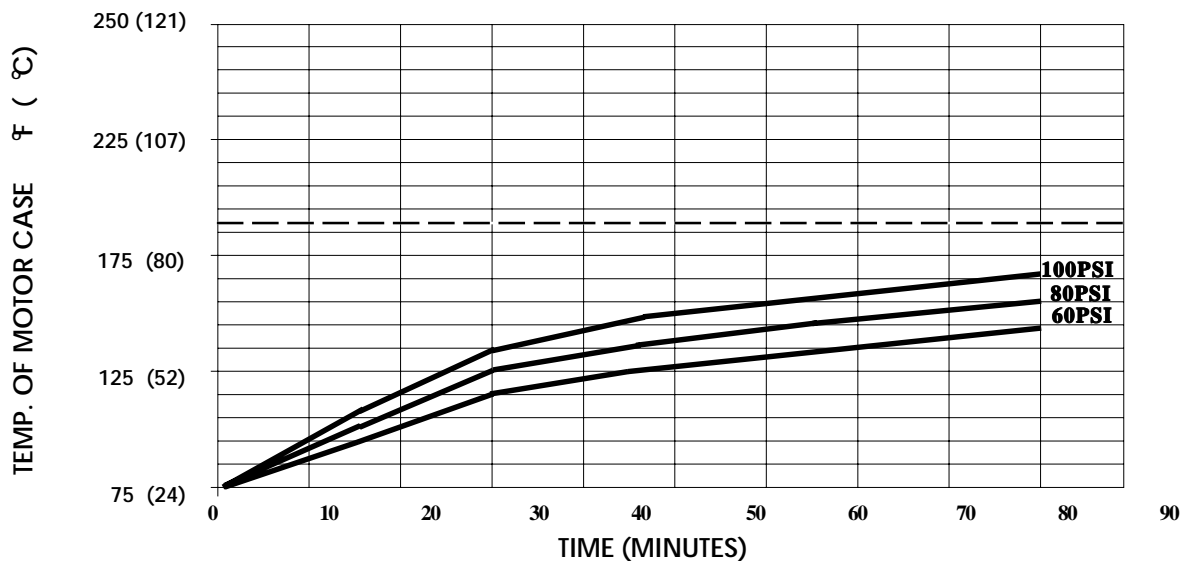

THIS GRAPH IS FOR USE AS A DESIGN GUIDE. IT IS BASED ON RUNNING CONTINUOUSLY WITH AN AMBIENT TEMPERATURE OF 70°F IN STILL AIR. THE THERMAL BREAKER WILL OPEN WHEN THE CASE TEMPERATURE REACHES 190°F.

[- - - - - TRIP POINT OF THERMAL PROTECTOR]

TYPICAL PERFORMANCE

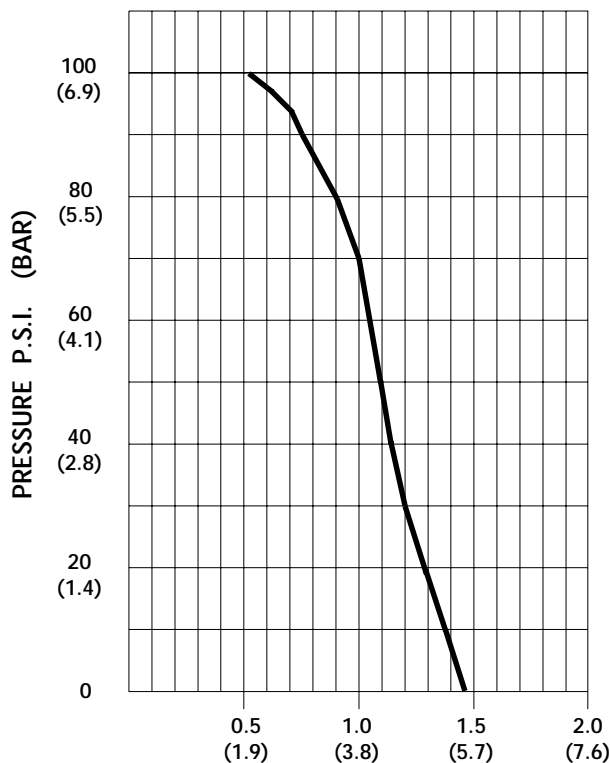

PRESSURE (PSI)	FLOW (GPM/LIT)	RPM MIN/MAX	CURRENT (AMPS)	VOLTAGE (VOLTS)
OPEN	1.45/5.5	2150/2190	0.32	115 VAC
10	1.38/5.2	2060/2110	0.37	"
20	1.29/4.9	1990/2020	0.43	"
30	1.22/4.6	1925/1940	0.48	"
40	1.16/4.4	1860/1875	0.53	"
50	1.10/4.2	1810/1815	0.58	"
60	1.05/4.0	1770/1760	0.63	"
70	0.97/3.7	1715/1725	0.68	"
80	0.90/3.4	1655/1685	0.73	"
90	0.75/2.8	1615/1630	0.76	"
100	0.50/1.9	1575/1590	0.82	"

FLOW - GALLONS PER MINUTE (LITERS PER MINUTE)

-SPECIFICATIONS SUBJECT TO CHANGE WITHOUT NOTICE.

For technical advice or service please take your pump into your local pump service center.

To order pump or parts or for pricing please go to the following links :

[Shurflo Pumps Home >>](#)

[Shurflo Pumps stock list >>](#)