

**PRODUCT DATA SHEET****MODEL: 8000-443-236****SPECIFICATIONS:****MODEL NUMBER:** 8000-443-236**PUMP DESIGN:** Positive Displacement 3 Chamber Diaphragm Pump**CHECK VALVE:** (1-Way Operation) Prevents Reverse Flow**CAM:** 3.0 Degree**MOTOR:** Permanent Magnet, P/N 11-111-00**VOLTAGE:** 12 VDC Nominal**PRESSURE SWITCH:** Adjustable Shut-Off (Range 40-60 PSI)Factory Set @ 60 PSI, Turn On 45PSI  $\pm$  5 PSI**LIQUID TEMPERATURE:** 170 Degrees Fahrenheit (77 Degrees Centigrade) Max.**PRIME:** Self-Priming Up To 12 Ft. Vertical,  
Max. Inlet Pressure 30 PSI (2.1 Bar)**PORTS:** 3/8" -18 NPT Female**MATERIAL OF CONSTRUCTION:****PLASTICS-** Polypropylene**VALVES-** EPDM**DIAPHRAGM-** Santoprene**FASTENERS-** Zinc Plated Steel**NET WEIGHT:** 4.56 Lbs (2.07Kg)**DUTY CYCLE:** Continuous (See Temperature Rise Chart)**TYPICAL APPLICATIONS:** Water Delivery**DIMENSIONS:**

**TEMPERATURE RISE**

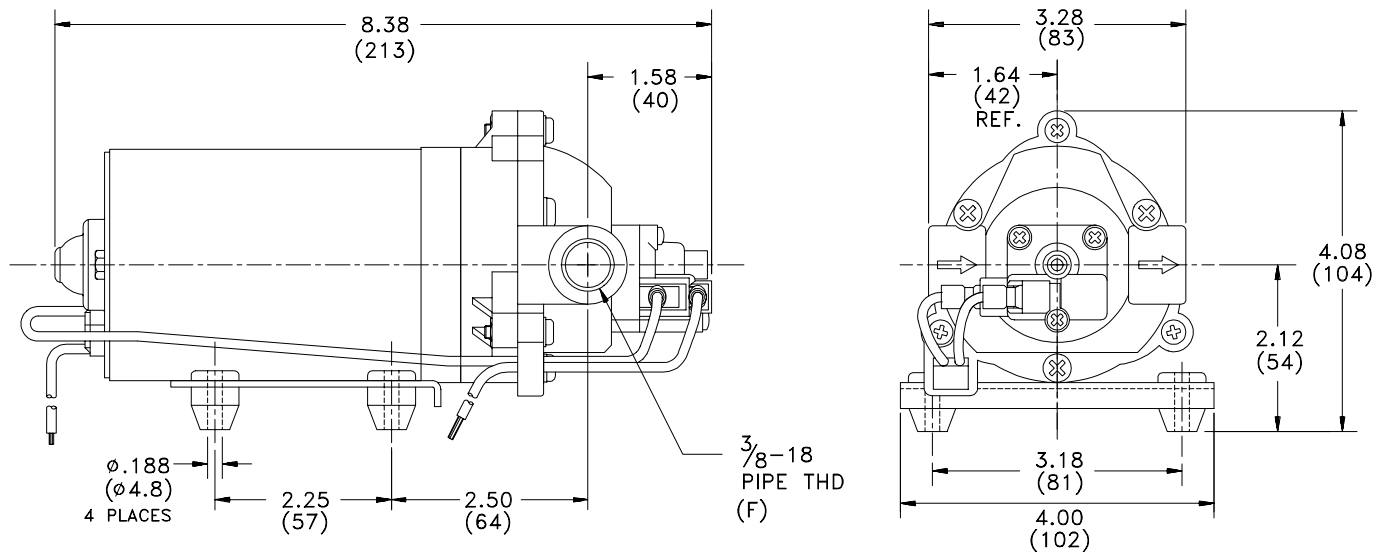
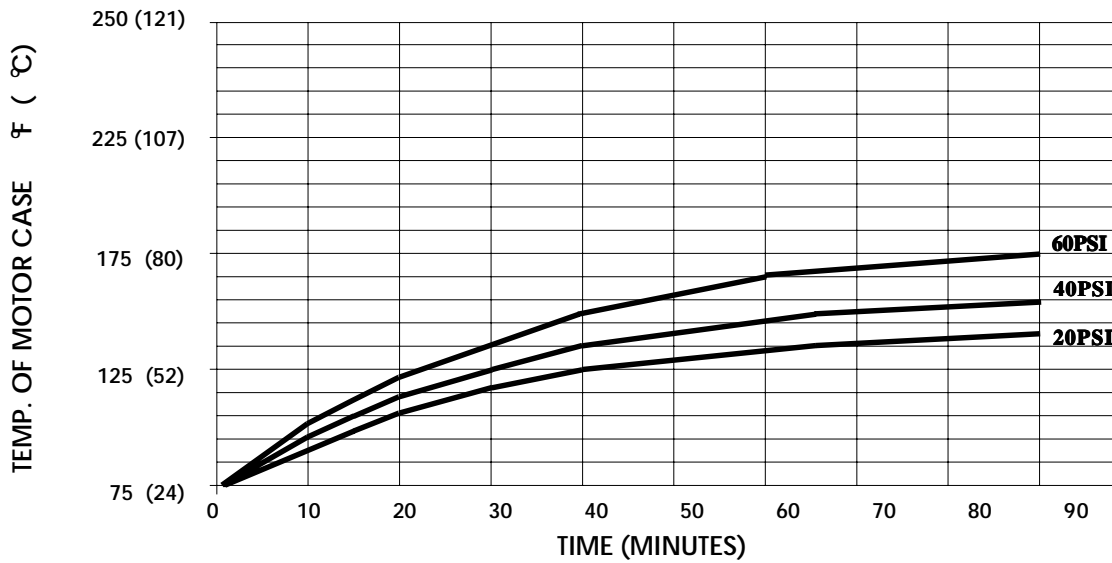

THIS GRAPH IS FOR USE AS A DESIGN GUIDE. IT IS BASED ON RUNNING CONTINUOUSLY WITH AN AMBIENT TEMPERATURE OF 70° F IN STILL AIR.

**TYPICAL PERFORMANCE**

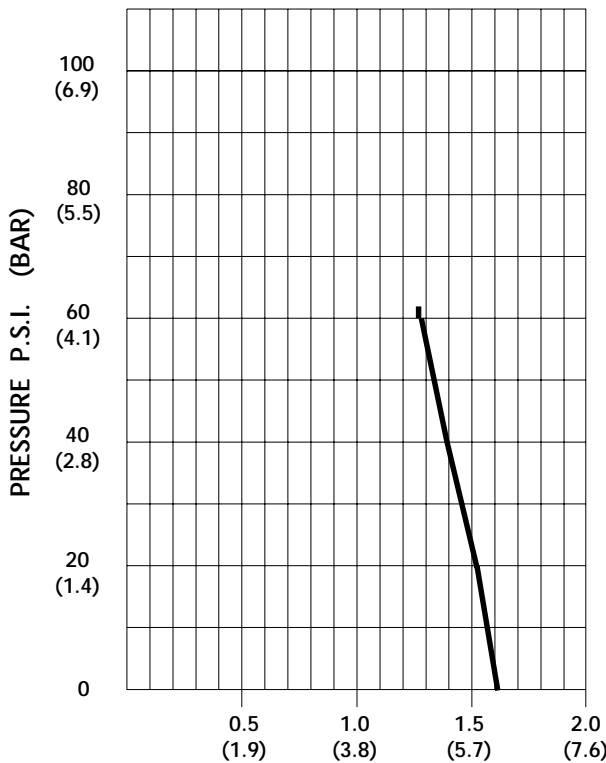

PRESSURE (PSI)	FLOW (GPM/LIT)	RPM MIN/MAX	CURRENT (AMPS)	VOLTAGE (VOLTS)
OPEN	<b>1.75/6.6</b>	<b>2290/2315</b>	<b>3.1</b>	<b>12VDC</b>
10	<b>1.66/6.3</b>	<b>225/2255</b>	<b>3.4</b>	"
20	<b>1.57/5.9</b>	<b>2170/2205</b>	<b>4.2</b>	"
30	<b>1.48/5.6</b>	<b>2130/2155</b>	<b>4.9</b>	"
40	<b>1.38/5.2</b>	<b>2045/2085</b>	<b>5.6</b>	"
50	<b>1.30/4.9</b>	<b>2020/2045</b>	<b>6.9</b>	"
60	<b>1.23/4.6</b>	<b>1893/1970</b>	<b>7.2</b>	"

FLOW - GALLONS PER MINUTE (LITERS PER MINUTE)

-SPECIFICATIONS SUBJECT TO CHANGE WITHOUT NOTICE.

-All PumpAgents.com buy pumps and parts online.

For technical advice or service please take your pump into your local pump service center.

To order pump or parts or for pricing please go to the following links :

[Shurflo Pumps Home >>](#)

[Shurflo Pumps stock list >>](#)