

~~X~~ Extreme™ Series



MARINE PRODUCT DATA SHEET

OEM: 5901-0201
AFTERMARKET: 5901-0211

The Smart Sensor 5.7 is designed specifically for cruisers and midsize yachts. Delivering over 5 GPM and pressure up to 60 PSI, this micro-controller based variable speed pump precisely monitors your system's water pressure and adjusts the motor speed, eliminating the need for an accumulator tank.

TYPICAL APPLICATIONS

Multi-fixture marine fresh water installations. Other uses may included 12V DC pressurized water systems in cabins This pump may be used for general water transfer. For other applications, contact SHURflo.

PUMP

Type: 5 Chamber Diaphragm
Ports: Quick Connect Fittings.
Liquid: 130 °F [54 °C] Max
Prime: 6 feet [1.82 M]
Inlet PSI: 30 PSI [2.1 Bar] Max
Run Dry: Yes

ELECTRICAL

Motor: 12VDC Permanent Magnet, Intermittent Duty
Protection: Thermal Overload, Automatic Restart
Leads: 14 AWG, 16" [40 cm] Red +, 13" [33 cm] Black -
Fuse: 15 Amp Recommended
Control: Shut-Off 60 PSI [3.1 Bar] ± 5 PSI [0.4 Bar]
Restart 30 PSI [1.8 Bar] ± 5 PSI [0.4 Bar]

MATERIALS

Housing: Nylon
Valves: EPDM
Diaphragm: Santoprene
Hardware: Stainless Steel

APPROVALS

Ignition Protected, CE, ISO 8846

WARRANTY

3 Year Limited Warranty
See SB-1041 & SB-1050 For Full Warranty
Details

SHIPPING

Net Weight (Boxed): 8.5 Lb [3.9 Kg] each
Carton Weight: 6 each, 51 Lb [24 Kg]
Carton Size: 25"L x 19"W x 8"H
[63 cm x 49 cm x 21 cm]

RELATED DOCUMENTS

Catalog: MS-030-140
Installation Manual: 911-621
Maintenance: 911-621
Applications Spec Guide: MS-020-005
Warranty: SB-1050

SERVICE KITS

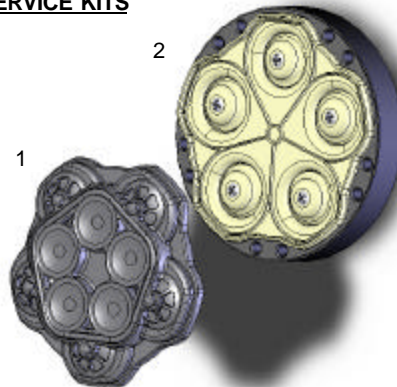

Item	Component	Part Kit
1	Valve Assembly	94-030-01
2	Drive Assembly	94-030-02

PERFORMANCE @ 12V DC

PRESSURE		FLOW		CURRENT
BAR	PSI	GPM	LPM	AMPS
0.0	0	5.5	20.8	5.0
0.7	10	4.0	15.1	9.0
1.4	20	3.0	11.3	9.6
2.1	30	2.5	9.46	9.4
3.5	50	1.5	5.67	10.3

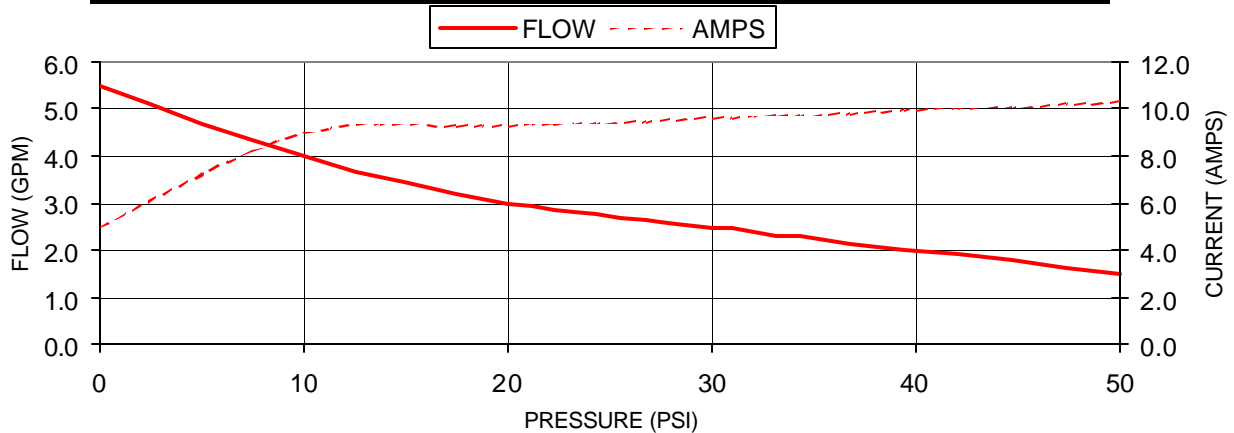

DIMENSIONS [mm]

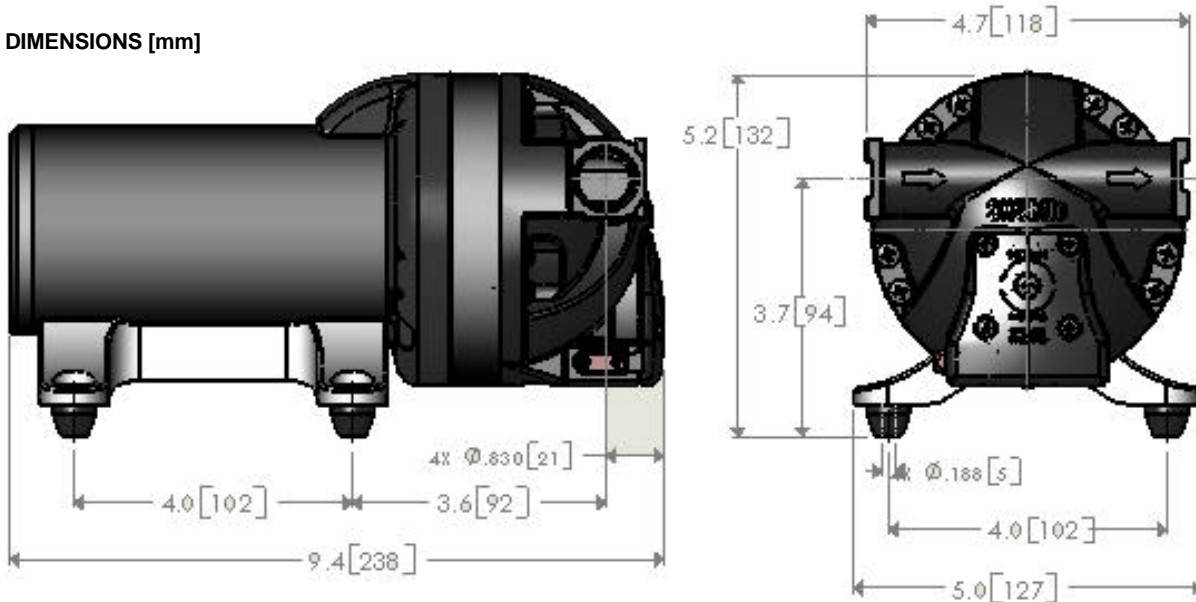

For technical advice or service please take your pump into your local pump service center.

To order pump or parts or for pricing please go to the following links :

[Shurflo Pumps Home >>](#)

[Shurflo Pumps stock list >>](#)