

SHURflo[®]*First in Fluid Innovation***PRODUCT DATA SHEET****MODEL: 2088-514-145****SPECIFICATIONS:****MODEL NUMBER:** 2088-514-145**PUMP DESIGN:** Positive Displacement 3 Chamber Diaphragm Pump**CHECK VALVE:** (1-Way Operation) Prevents Reverse Flow**CAM:** 3.0 Degree**MOTOR:** Permanent Magnet, P/N 11-185-06, Thermally Protected**VOLTAGE:** 12 VDC Nominal**PRESSURE SWITCH:** Splash-Proof, Adjustable from 30 to 50 PSI.Factory Set @ 45 PSI Shut-Off, Turn On 25 PSI \pm 5 PSI**LIQUID TEMPERATURE:** 130 Degrees Fahrenheit (54 Degrees Centigrade) Max.**PRIME:** Self-Priming Up To 9.0 Ft. Vertical,

Max. Inlet Pressure 30 PSI (2.1 Bar)

PORTS: 1/2"-14 Male Parallel Thread**MATERIAL OF CONSTRUCTION:****PLASTICS-** Polypropylene**VALVES-** Santoprene**DIAPHRAGM-** Santoprene**FASTENERS-** Stainless Steel**NET WEIGHT:** 6.8 Lbs (3.1 Kg)**DUTY CYCLE:** Continuous (See Temperature Rise Chart)**TYPICAL APPLICATIONS:** Potable Water**APPROVALS:** N.S.F. Listed**DIMENSIONS:**

TEMPERATURE RISE

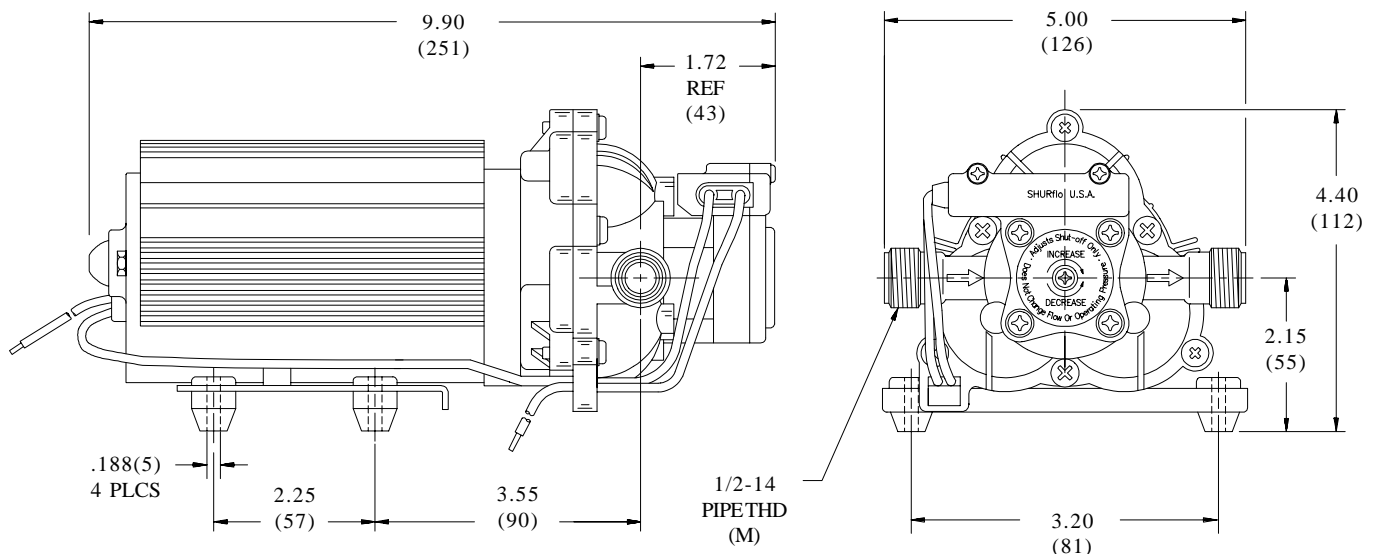
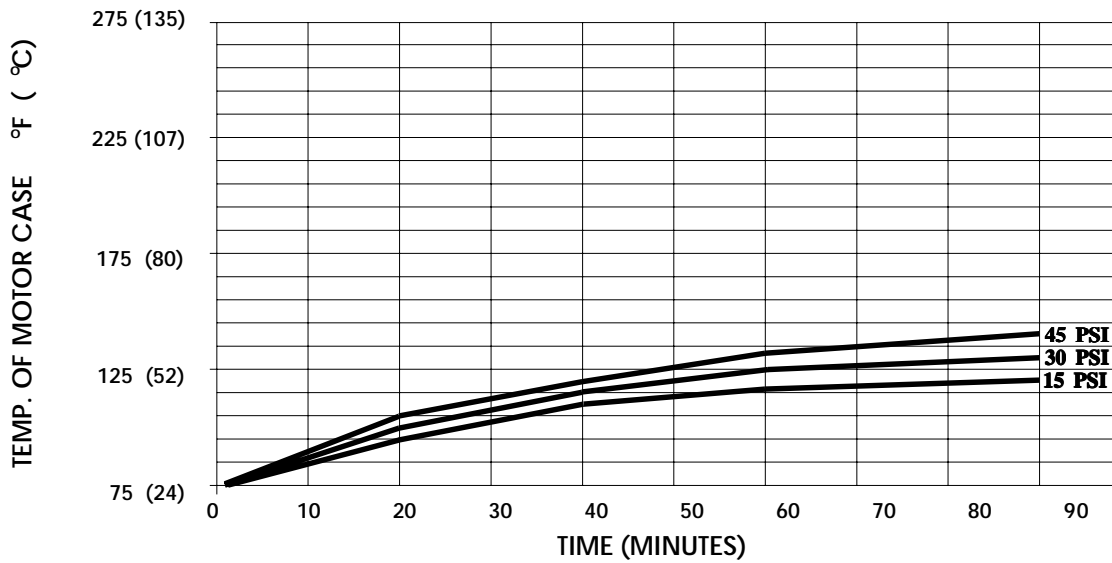

THIS GRAPH IS FOR USE AS A DESIGN GUIDE. IT IS BASED ON RUNNING CONTINUOUSLY WITH AN AMBIENT TEMPERATURE OF 70°F IN STILL AIR. THE THERMAL BREAKER WILL OPEN WHEN THE CASE TEMPERATURE REACHES 280°F.

TYPICAL PERFORMANCE

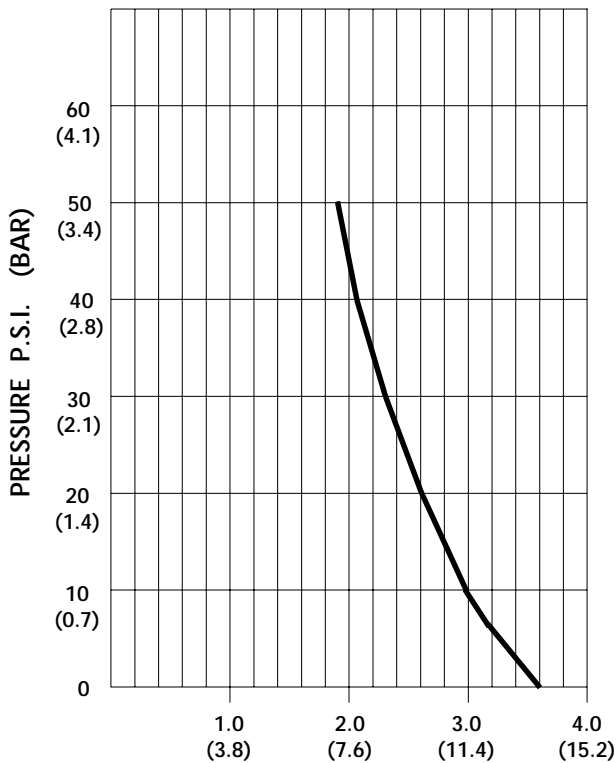

PRESSURE (PSI)	FLOW (GPM/LIT)	RPM MIN/MAX	CURRENT (AMPS)	VOLTAGE (VOLTS)
OPEN	3.60/13.6	2330/2465	4.5	12 VDC
10	2.90/11.0	2320/2460	5.6	"
20	2.60/9.8	2275/2405	7.1	"
30	2.30/8.7	2250/2365	8.4	"
40	2.07/7.8	2220/2335	9.0	"
50	1.90/7.2	2205/2315	9.5	"

FLOW - GALLONS PER MINUTE (LITERS PER MINUTE)

-SPECIFICATIONS SUBJECT TO CHANGE WITHOUT NOTICE.

For technical advice or service please take your pump into your local pump service center.

To order pump or parts or for pricing please go to the following links :

[Shurflo Pumps Home >>](#)

[Shurflo Pumps stock list >>](#)