

Little GIANT

Franklin Electric Co., Inc.
 P. O. Box 12010
 Oklahoma City, OK 73157-2010
 405.947.2511 • Fax: 405.947.8720
 www.LittleGiantPump.com
 CustomerService-WTS@fele.com

RFSN-6 RFSN-9 RFSN-10

Liquid Level Control
 Non-Mercury/Float Type

INTRODUCTION

The Little Giant liquid level control is designed to be used with Little Giant Effluent and Sewage pumps or other pumps rated 13 Amps or less.

Little Giant products are carefully packaged, inspected and tested to insure safe operations and delivery. When you receive your switch, examine it carefully to determine that there are no parts missing or which may have been damaged or broken during shipment. If damage has occurred, make notation and notify and/or return to the firm from which you purchased the switch and they will assist you in replacement or repair.

SAFETY GUIDELINES



1. Read all instructions and safety guidelines thoroughly. Failure to follow guidelines and instructions could result in serious bodily injury and/or property damage.
2. During operation, the area around the pump and switch may be covered with water. Take care when handling switch or pump. Do not pull pump out of the water by the power cord.
3. Disconnect all electrical service to the pump and unplug the pump and/or switch before working on the unit or handling the unit.
4. Make sure all outlets used are grounded.
5. Do not stand in water while changing fuses, resetting circuit breakers or repairing switch or pump.

Figure 1.

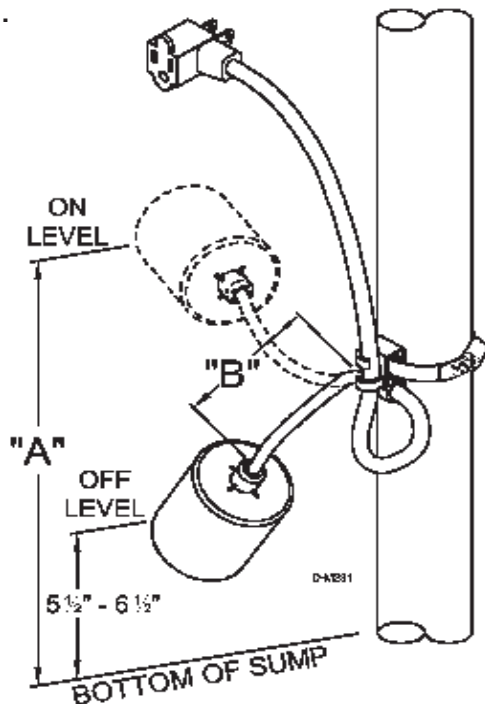
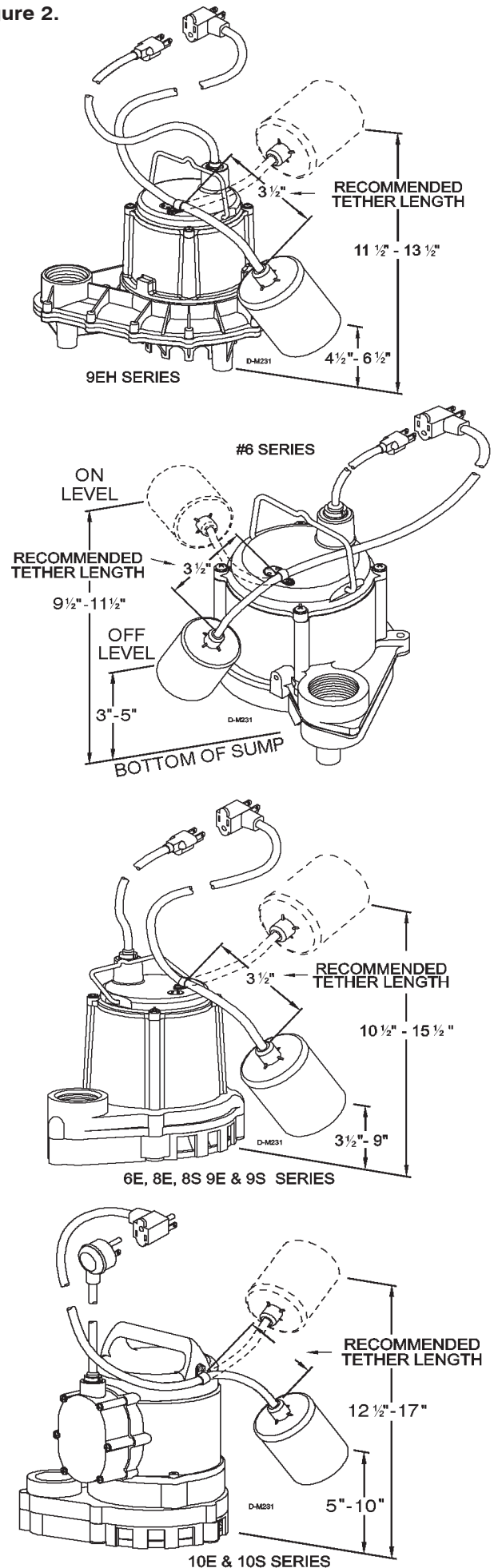

Figure 2.



ELECTRICAL CONNECTIONS



1. The level control switch is supplied with three-prong grounding plug. The switch must be used with pumps that are equipped with three-prong grounding plugs. Do not remove the third pin from the plug. The receptacles should be properly grounded, grounding-type receptacle.
2. Separate branch circuit is recommended. Do not use extension cord.
3. Be sure electrical connections cannot be reached by rising water. Under no circumstances should outlet box or receptacle be located where it may become flooded or submerged by water.

INSTALLATION

If screw which is provided is lost, use only a #10-16 x 1/2" long tapping screw. Longer screws can crack the cover.

1. Attach cord clamp to pump cover as shown. The clamp and pump handle must be positioned as shown to allow free operation of float. Be sure to locate and switch power cords away from switch float.
2. A minimum tether length of 3 1/2" is recommended for use on the #6E, #8E, #8S, #9E, #9S, 9EH, #10E, and #10S series pumps. Tether length to be 3 1/2" when attached to pump on the #6 series pumps. The tether length is measured as shown in Figure 2.
3. A sump with a minimum diameter of 14" is required for the #6 series sump pumps.
4. A sump with a minimum diameter of 18" is required for the #6E, #8E, #8S, #9E, #9S, #9EH, #10E and 10S series pumps.
5. After desired tether length is established, hand tighten clamp screw.
6. For universal installation, refer to Figure 1.
 - a. Attach switch cord using the cable tie provided to any convenient rigid surface about 2" below the desired turn-on level. Do not tighten cable tie until turn-on and turn-off levels are established
 - b. Increase cord length between float and tie point increases on-off differential. Decreasing cord length between float and tie point decreases on-off differential.
 - c. Tighten cable tie securely after turn-on and turn-off levels are established.

CAUTION: To prevent damage to pump, do not set switch turn-off level below 2" above bottom of pump base. Also be certain that pump is secured in position so float cannot become stuck between the pump and the basin which could prevent pump from coming on or going off. Be certain cable tie is secure so switch cord does not accidentally slip and change set on/off levels.

SWITCH ADJUSTMENTS

(approximate measurements, in inches)

Pumping Range (Dim "A")	5.5	6	8	12	13	18	19	23	25
Tether Length (Dim "B")	3	4	6	8	10	12	13	15	17

TESTING

Without water in sump, plug pump cord into the back of the switch plug. Plug switch into outlet. Lift float and listen for pump to operate. Do not run pump for more than 5 seconds. Next, run water into sump where pump is installed. Fill the sump to the "on" level and allow the pump to remove water to the "off" level. Make adjustment per chart on opposite page if needed.

DIRECT WIRING

FOR DIRECT WIRING INSTALLATION, REFER TO FIGURE 3 (SCHEMATIC).

WARNING: In a 230V direct wire installation, one side of the line going to the pump is always "HOT". This condition exists whether the float switch is "ON" or "OFF". To avoid hazards when installing or servicing, install a double-pole disconnect near pump installation.

Check local electrical and building codes before installing. This installation must be in accordance with their regulations as well as the most recent edition of the National Electrical Code Handbook (NEC).

MANUAL PUMP OPERATION POSSIBLE BY PLUGGING PUMP DIRECTLY INTO OUTLET. (Plug configuration may vary depending on voltage.)

NOTE: Little Giant Pump Co. cannot be responsible for damages caused by the faulty or negligent installation of this control. If you feel that you may encounter problems in installing this device, we respectfully suggest you engage the services of a competent plumber, electrician, or qualified service person.

ADDITIONAL INFORMATION

CAUTION: To prevent damage to pump, do not set switch turn-off level below 2" above bottom of pump base. Also, be sure that the pump is secured in its position so the float will not become stuck between the pump and the basin, which could prevent the pump from turning "ON" or "OFF". Be sure the cable tie is secure so the switch cord does not accidentally slip and change the pre-set ON/OFF levels.

LIMITED WARRANTY

Your Little Giant product is guaranteed to be in perfect condition when it leaves our Factory. It is warranted against defective materials and workmanship for a period of 12 months (90 day warranty on Models: 1-AA-OM, GKPK-SC, PP-1, PPS-1, PP-12, PPS-12 , PP-230 and Cooler King) from date of purchase by the end user. No warranty on brush wear in Model 35-OM and impeller or cam in Models PP-1, PP-12, and PP-230. Any product that should fail for either of the above two reasons and is still within the warranty period will be repaired or replaced if returned prepaid to our Factory. All defective product returned under warranty will be fully inspected to determine "cause of failure" before warranty is approved. Little Giant will honor the warranty within the warranty time period specified on satisfactory written proof of purchase.

DISCLAIMER: Any oral statements about the product made by the seller, the manufacturer, the representatives or any other parties, do not constitute warranties, shall not be relied upon by the user, and are not part of the contract for sale. Sellers and manufacturers only obligation, and buyers only remedy, shall be the replacement and/or repair by the manufacturer of the product as described above. Neither seller nor the manufacturer shall be liable for any injury, loss or damage, direct, incidental or consequential (including, but not limited to, incidental or consequential damages for lost profits, lost sales, injury to person or property, or any other incidental or consequential loss), arising out of the use or the inability to use the product, and the sure agrees that no other remedy shall be available to it. Before using, the user shall determine the suitability of the product for his intended use, and user

assumes all risk of liability whatsoever in connection therewith. The warranty and remedy described in this limited warranty is an EXCLUSIVE warranty and remedy and is IN LIEU OF any other warranty or remedy, expressed or implied, which other warranties and remedies are hereby expressly EXCLUDED, including but not limited to any implied warranty of MERCHANTABILITY OR FITNESS FOR A PARTICULAR PURPOSE. Some states do not allow the exclusive or limitation of incidental or consequential damages, so the above limitation or exclusion may not apply to you. This warranty gives you specific legal rights, and you may also have other rights which vary from state to state.

Warranty will be VOID if any of the following conditions are found:

1. Sealed motor housing opened.
2. Product connected to voltage other than indicated on nameplate.
3. Cord cut off to a length less than three feet.
4. Pump allowed to operate dry (fluid supply cut off).
5. Pump used to circulate anything other than fresh water, light oils, or other mild liquids at approximately room temperature.
6. Product abuse by customer.

The National Electric Code requires a Ground Fault Circuit Interrupter (GFCI) be installed in the branch circuit supplying fountain equipment rated above 15 volts. Part number 599335, GFCI-1, is in stock and we recommend each pump be used with a GFCI.

For Parts or Repair, please contact1.888.572.9933
For Technical Assistance, please contact1.888.956.0000

www.LittleGiantPump.com
CustomerService-WTS@fele.com
