

Little GIANT[®]

6-CIA-VDS



Features

- Cast iron pump housing with protective epoxy coating for corrosion resistance
- Oil-filled motor housing for lifetime lubrication and rapid heat dissipation
- 1/3 HP Shaded Pole Motor
- Stainless steel screws, bolts and handle to protect against corrosion
- Mechanical seal (stainless steel spring, nitrile parts, carbon and ceramic faces) to assure maximum protection against pump failure
- Bearings: Upper and lower sintered sleeve bearings for extended motor life
- Thermal overload protection
- Automatic operation with piggyback diaphragm switch activates pump when water level is approximately 9". Pump shuts off when water level is approximately 3". (Pressure switch is non-adjustable.)

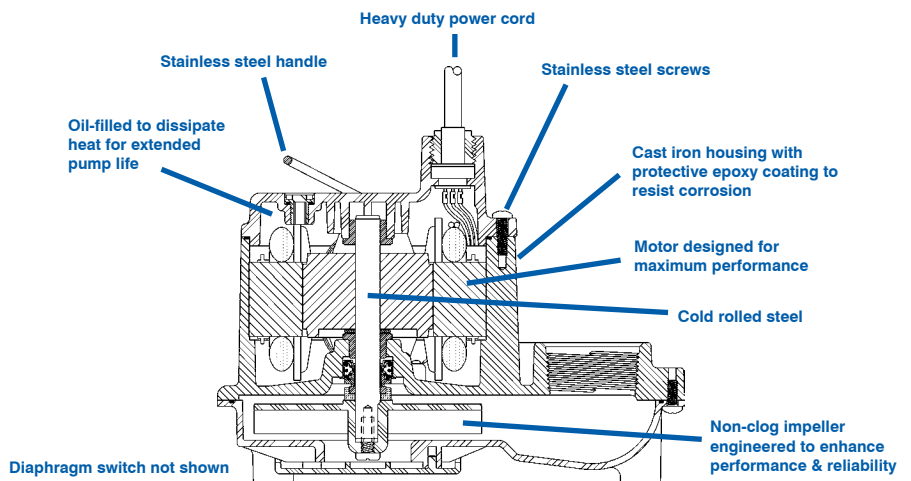

For residential and light commercial use, the 6-CIA-VDS sump pumps provide efficient and reliable service. For extended or continuous use in moving large volumes of water, these pumps feature a 1-1/2" discharge with a maximum lift of 18', a polycarbonate cover and a polypropylene volute/base. The pump is equipped with a piggyback vertical diaphragm switch for limited-space applications.

6-CIA-VDS

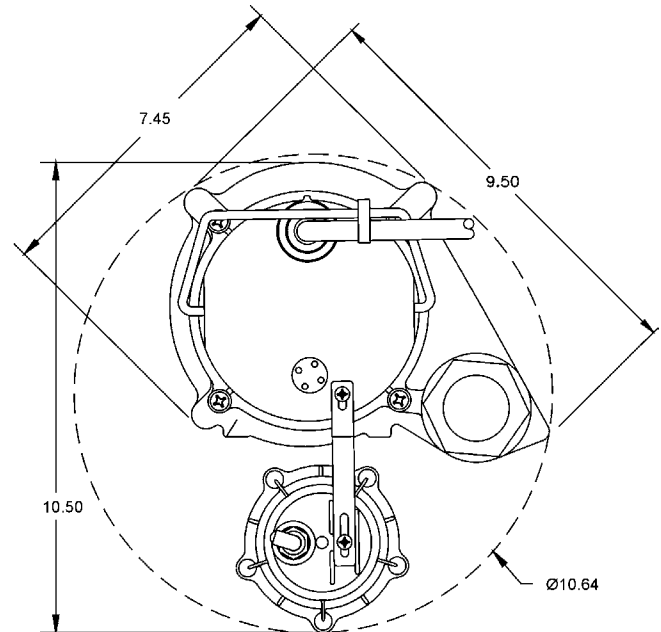
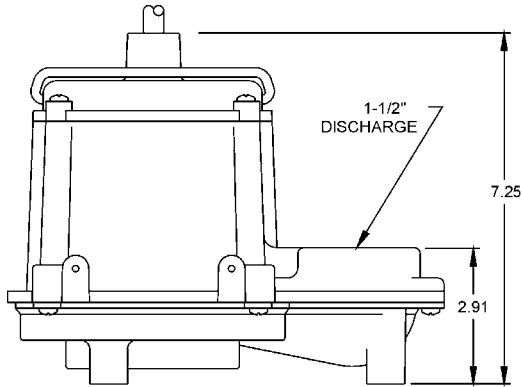

Specifications

Model No.	Item No.	Listings	HP	Volts	Amps R	Watts	Performance (GPM @ Head)			Shut Off		Pwr. Cord (ft.)	Weight (lbs.)	Height	Length	Width
							5'	10'	15'	Feet	PSI					
6-CIA-VDS	506268	UL/CSA	1/3	115	9.0	720	46	29	12.5	18	7.8	10	16.50	7.25	9.50	10.50

Continuous Duty Rated — "Little Giant Wastewater pumps are rated continuous duty as long as they are run within the published ratings for these pumps."

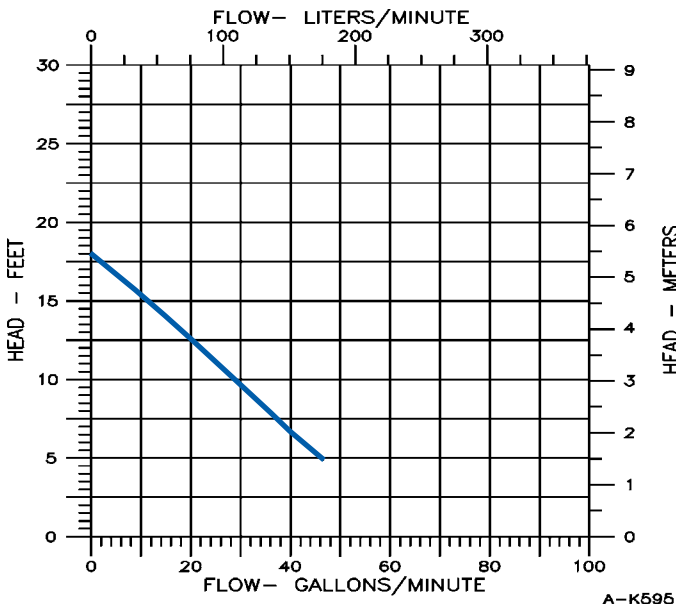

Construction

Cover	Polycarbonate
Motor Housing	Epoxy coated cast iron
Impeller Material	Nylon
Impeller Type	Non-clog
Volute	Polypropylene
Power Cord	18/3 SJOW-A
Mechanical Shaft Seal	Nitrile w/carbon & ceramic faces
Fasteners	Stainless steel
Shaft	Cold rolled steel
Bearings	Upper: sintered iron/copper, flanged sleeve Lower: sintered iron/copper, flanged sleeve