



Model: 8860-0001

SELF-PRIMING PUMP Mini-Puppy FEATURES

- Body:** Bronze
- Impeller:** Neoprene
- Seal:** Lip Type
- Motor:** Permanent Magnet Type, Fully enclosed, Stainless Steel Shaft
- Ports:** 3/8" Pipe Thread Internal
Plus an adaptor for 3/4" garden hose thread
- Height:** 3-3/8" (85 mm)
- Length:** 6-3/4" (172 mm)
- Width:** 3-3/4" (95 mm)
- Weight:** 4-1/2 lb (2 kg)(approx.)



Model: 8860-0001

⚠ WARNING Explosion hazard. Do not pump gasoline, solvents, thinners or other flammable liquids. To do so can cause an explosion resulting in injury or death.

⚠ WARNING Explosion hazard. Do not operate with rivets removed from motor case. Explosion resulting in personal injury, death or property damage can occur. Case openings must be sealed to avoid explosion and maintain ignition protected rating.

APPLICATION

Use for bilge pumping, livewell circulation, washdown and general pumping requirements. When bilge water contains significant amounts of oil, use impeller No. 14750-0003. For intermittent duty, motor may be reversed.* With a wet impeller, pump will produce a suction lift of about 4 feet (1, 2m) and a lift to 15 feet (5m) when primed. BE SURE SUCTION LINES ARE AIRTIGHT.

INSTALLATION

The pump must be mounted in a dry location - the motor is not waterproof and must not be submerged. SELECTION OF A COOL location will generally extend pump motor life. The unit can be mounted in any desired position. It is best to mount so that water dripping from loose port connection will not wet the motor. The pump head may be rotated 180° degrees on the motor to reverse direction of flow.

*To prolong motor life, install pump so normal motor rotation is clockwise. Polarity reversing switch not included with pump.

Motor meets USCG Electrical Standards (Title 33, Chapter 1, Part 183; Subpart 1) for IGNITION PROTECTION on gasoline powered vessels.

PLUMBING CONNECTIONS

Pump has external garden hose threads and internal 3/8" pipe threads. Use hose that does not kink when bent and with sufficient wall thickness to prevent collapse when used on suction side of pump. Hoses should be routed so that some water will be retained in pump body to wet the impeller. Wetting the impeller aids in priming and extends impeller life. Use a strainer on the intake hose to stop trash and solids from going through the pump. All hoses must have airtight connections to enable faster priming.

PSI	TOTAL HEAD		CAPACITY	
	FEET	METRES	GPM	I/MIN
2.1	5	1,5	1.8	6,8
4.3	10	3,0	1.7	6,4
8.7	20	6,1	1.4	5,3
13.0	30	9,1	1.0	3,8

Table shows approximate Head-Flow for new pump.

ELECTRICAL CONNECTIONS

⚠ WARNING Explosion hazard. If pump is operated in an area containing flammable vapors, wire leads must be joined by insulated mechanical locking connectors. Loose or inadequate wire connections can spark resulting in an explosion. Property damage, injury or death can occur.



Connect black wire to negative (-) terminal of battery. The orange wire should be connected to an overload protected fuse or circuit breaker panel. The positive conductor should include an on-off switch with a minimum 10 amp rating. Electrical circuit must be independent of all other accessories. A reversing switch which switches motor polarity may be used to reverse pump for intermittent duty cycles. Preferred motor rotation is clockwise looking at shaft end of motor.* Use proper wire size as determined by wire table elsewhere on this sheet. Should the fuse blow, replace with the same size fuse after determining reason for blown fuse.

WIRING DIAGRAM

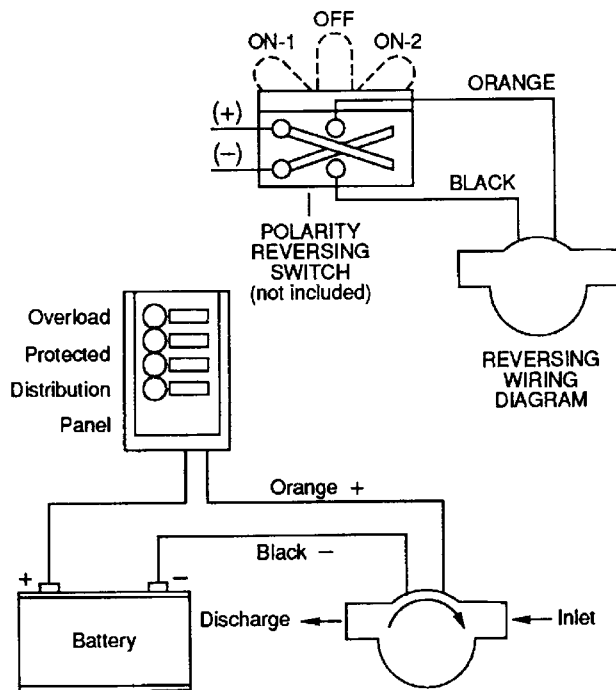

AMPERE DRAW

Model No.	Voltage	Amp Draw	Fuse Size
8860-0001	12 Vdc	4	1 OA-3AGC

* To prolong motor life, install pump so normal motor rotation is clockwise.

MINIMUM WIRE SIZES

Connection Length Between Battery and Motor	12 Vdc
1 -10ft (3m)	#14
11 -20 ft (6m)	#12
21-30 ft (9m)	#10

OPERATION

NOTICE - Do not pump solvents, thinner, or petroleum derivatives. Impeller and motor damage will occur.

⚠ CAUTION Motor runs hot; about 180°F is a normal temperature. Prolonged contact during operation may cause a burn.



Flexible impeller pumps must NOT be run dry, as the pumped liquid is the lubricant for the impeller. Observe the outlet and shut off pump as soon as liquid stops flowing. An automatic level switch is convenient to control the pump.

The pump cannot run against a closed outlet such as encountered when using a garden hose type shut-off nozzle.

Temperature of pumped liquid may be in the range of 45°–160°F (10°–70°C).

Pressure for normal operation should not exceed 35 feet of head (15 psi).

EXPLODED VIEW

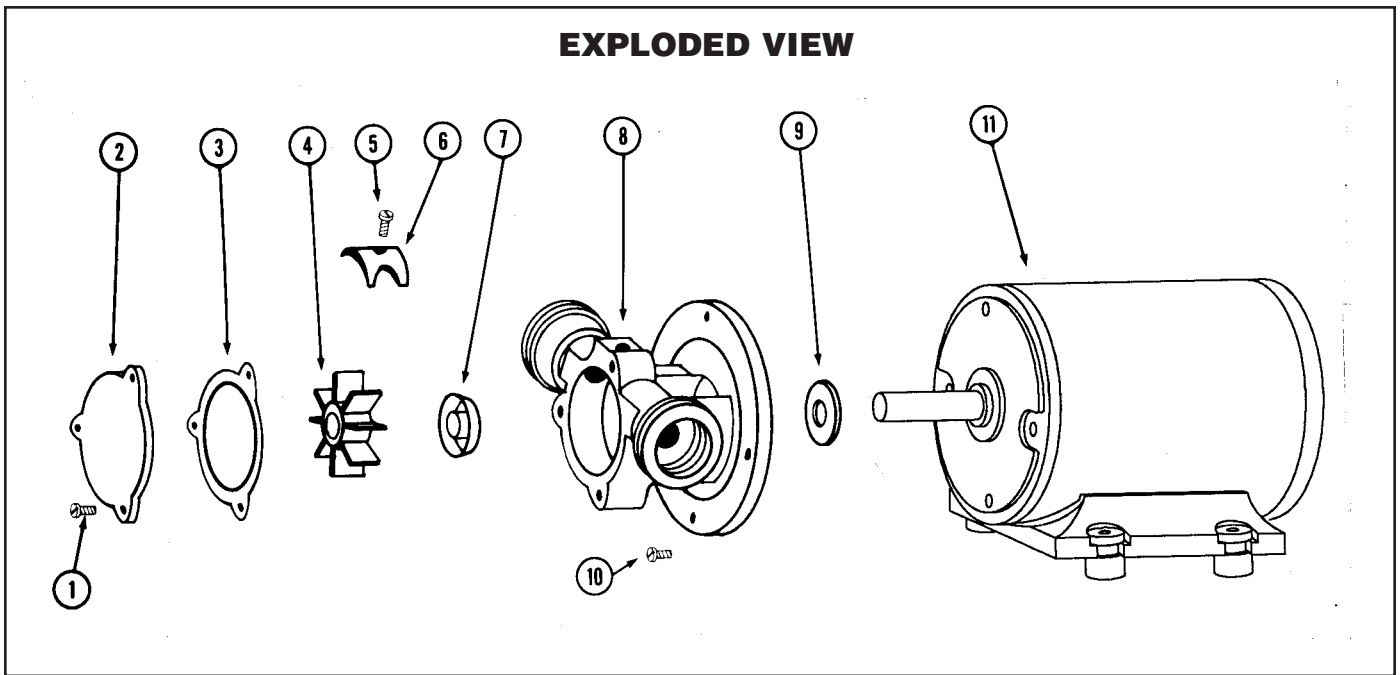

KEY	DESCRIPTION	PART NUMBER	QTY.
1	Screw (End Cover)	91002-0090	3
2	End Cover	12076-0000	1
3	*Gasket	7828-0000	1
4	*Impeller, Neoprene	14750-0001	1
	†Impeller, Nitrile	14750-0003	
5	Screw (Cam)	91002-0010	1
6	Cam	8089-0000	1
7	*Seal	93000-0100	1
8	Body	7824-0000	1
9	Slinger	6342-0000	1
10	Screw (Body to Motor)	98019-0060	2
11	Motor, 12V	98019-0020	1
	Service Kit, Neoprene	90092-0007	
	†Service Kit, Nitrile	90092-0004	
	Pump Head Only	9040-0001	

* Parts contained in Service Kit.

† Use Nitrile impeller for extreme condition of oil in bilge water.

DISASSEMBLY

1. Remove end cover screws, end cover and gasket.
2. Grasp hub of impeller with pliers and remove impeller.
3. Remove cam screw and cam from pump body and clean sealant from top of cam, pump body and screw.††
4. Remove pump body from motor and deform seal so that it can be pulled from seal cavity.
5. Clean all parts and inspect for wear.

††Cam removal is not required if replacing impeller and seal only.

ASSEMBLY

1. Install seal in seal cavity with lip pointing toward impeller bore.
2. Ensure the slinger is positioned on the shaft (next to motor) and install pump body on motor.
3. Apply a thin coat of sealant on top of cam and install cam in body.
4. Install impeller with a clockwise rotary motion to bend blades under cam.
5. Install end cover and gasket, tightening screws evenly.

MAINTENANCE

Check wires and connections to be sure corrosion is not adding additional resistance to the motor circuit and causing a low voltage condition at the motor. Low voltage can inhibit starting and cause fuse to blow. Full voltage should be available to prevent motor damage.

If pump is idle for extended periods, the impeller may stick to the pump body, preventing motor rotation and causing blown fuses. To correct, remove end cover and impeller. Clean body and impeller, then lubricate with water or small amounts of grease before assembly.

If pump is to be in freezing temperatures, drain by loosening end cover screws.

A service kit, or at least a spare impeller, should be carried aboard to be assured of pumping capability.

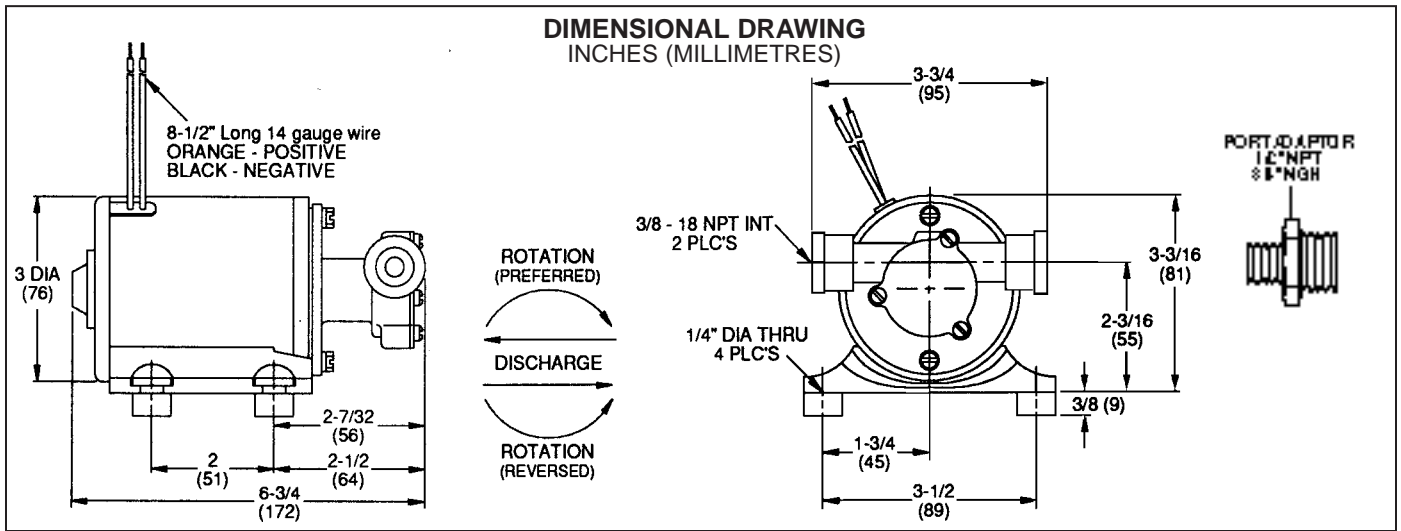

One Year Limited Warranty

A. LIMITED WARRANTY: ITT warrants that at the time of shipment, the products manufactured by ITT and sold hereunder shall be in conformity with applicable written specifications and descriptions referred to or set forth herein, free from defects in material and workmanship, merchantable, and suitable for a particular purpose, provided such is implied by State law under the circumstances of this sale.

B. WARRANTY ADJUSTMENT:

1. ITT agrees to repair or furnish a replacement for, but not to remove or install, any product or component thereof which, within one (1) year from date of purchase, shall upon test and examination by ITT prove defective within the above warranty. Receipt verifying purchase date is required to obtain adjustment.
2. Buyer shall notify ITT of any defect within this warranty no later than ninety (90) days after the defect is discovered.
3. No product will be accepted for return or replacement without the prior written authorization of ITT. Upon such authorization, and in accordance with instructions from ITT, the product will be returned to ITT, shipping charges prepaid by Buyer. Products returned to ITT will be addressed as follows:

ITT JABSCO
1485 Dale Way
Costa Mesa, California 92626-3998

Or to such alternate locations as may be designated on the product, its container, or this sheet.

Repair or replacement made under this warranty will be shipped prepaid to Buyer

C. EXCLUSIONS FROM WARRANTY AND LIMITATION OF LIABILITY:

1. The foregoing warranty is limited solely as set forth herein and applies only for the period designated above.

2. ITT SHALL NOT BE LIABLE FOR ANY LOSS, DAMAGE, SPECIAL OR CONSEQUENTIAL DAMAGE OF ANY KIND, WHETHER BASED UPON WARRANTY, CONTRACT, NEGLIGENCE, OR STRICT LIABILITY ARISING IN CONNECTION WITH THE SALE, USE, OR REPAIR OF THE PRODUCT.
3. THE MAXIMUM LIABILITY OF ITT IN CONNECTION WITH THIS WARRANTY SHALL NOT IN ANY CASE EXCEED THE CONTRACT PRICE FOR THE PRODUCT CLAIMED TO BE DEFECTIVE OR UNSUITABLE.
4. This warranty does not extend to any product manufactured by ITT which has been subjected to misuse, neglect, accident, improper installation, or use in violation of instructions furnished by ITT.
5. This warranty does not extend to or apply to any unit which has been repaired or altered at any place other than ITT's factory, or by persons not expressly approved by ITT, nor to any unit the serial number, model number, or identification of which has been removed, defaced or changed.
6. Components manufactured by any supplier other than ITT shall bear only that warranty made by the manufacturer of that product.
7. This warranty applies to products defined as "consumer products" by the Consumer Product Warranties Act as from time to time amended.

D. CONSUMER RIGHTS: This warranty gives you specific legal rights, and you may have other rights which vary from state to state. Some states do not allow exclusion or limitation of damages.

STANDARD WARRANTY: If the products manufactured and sold hereunder are not Consumer Products, the warranty extended to Buyer shall be as set forth in subparagraphs (A), (B), and (C), **EXCEPT THAT ALL EXPRESS OR IMPLIED WARRANTIES OR MERCHANTABILITY OR SUITABILITY FOR ANY PARTICULAR PURPOSE ARE EXCLUDED.**

Jabsco



U.S.A.
Jabsco
20 Icon
Foothill Ranch, CA 92610-3000
Tel: (949) 609.5106
Fax: (949) 859.1254

UNITED KINGDOM
Jabsco
Bingley Road, Hoddesdon
Hertfordshire EN11 OBU
Tel: +44 (0) 1992 450145
Fax: +44 (0) 1992 467132

CANADA
Fluid Products Canada
55 Royal Road
Guelph, Ontario N1H 1T1
Tel: (519) 821 -1900
Fax: (519) 821-2569

JAPAN
NHK Jabsco Company Ltd.
3-21-10, Shin-Yokohama
Kohoku-Ku, Yokohama, 222
Tel: 045-4758906
Fax: 045-475-8908

GERMANY
Jabsco GmbH
Oststrasse 28
22844 Norderstedt
Tel: +49-40-53 53 73 -0
Fax: +49-40-53 53 73 -11