

JABSCO®

50830 Series Low Pressure Centrifugal Pump

"CYCLONE PUMP"

Stainless Steel DC Motor / Pump Unit

A range of Stainless Steel General Purpose Centrifugal pumps designed specifically for the marine and industrial markets. Typical applications would be for circulation applications such as hot water systems, livewell or bait tank installations.

Features & Benefits

- Heavy duty robust stainless steel construction
- One tool servicing (3/8" Spanner)
- Virtually silent running centrifugal pump
- Long-life DC motor
- Rotatable head 90° segments
- Anti-clogging impeller design
- Long-life mechanical seal

Specification

Duty Cycle: Continuously rated @ 68°F (20°C) ambient, 122°F (50°C) Fluid temperature at the Operating Point (see Performance Curve)

Motor Brush Life: 3500 hrs

Suction Lift: 6.5 feet (2 metres) when wetted

Relevant Standards:

ISO 8846 MARINE and USCG Regulations for Ignition Protection.

ISO 8849 MARINE Bilge Pump Standard

Performance Curve

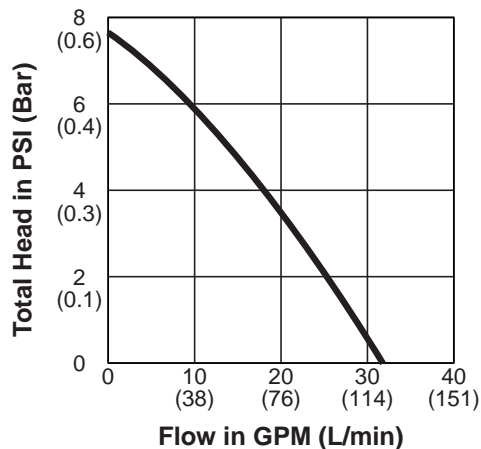

Part Numbers

Model	Voltage	Amp Draw	Fuse Size	Port Fitting
50830-0012	12Vdc	7	10	3/4" NPT
50830-0024	24Vdc	3.5	5	3/4" NPT



WARNING: Do not use any JabSCO pump for petrol, petroleum products or any products with a flash point below 98F (37°C), explosion or death may occur.

Installation Instructions

JabSCO Cyclone Centrifugal Pump can be mounted on any flat surface. Fit the pump in a dry, well ventilated position where there is full access for service. If installed in a vertical position, the motor must be above the pump head. Use the rubber grommets provided to minimize vibration. Do not over tighten the mounting screws.

Please Note: The pump must be fitted below fluid feed to maintain flooded suction.



WARNING: All marine pumps discharging overboard must be installed with the overboard discharge well above both static and heeled waterlines.

JABSCO®

50830 Series Low Pressure Centrifugal Pump

Plumbing Connections

The intake and outlet ports have internal 3/4" pipe threads. Brass or plastic pipe fittings may be used to suit the installation. Plastic fittings that may be subject to cracking due to vibration should not be used below the waterline. TFE pipe joint tape or compound should be used if brass fittings are installed in the pump ports.

Operation

The pump may be run dry for short periods of time. However, running without liquid allows heat to build up between seal faces, thus shortening seal life. The pump can run against a closed outlet such as encountered when using a garden hose type shut-off nozzle.

Maintenance

Check all electrical connections periodically, particularly in salt water areas. Corrosion can cause loss of performance or non-operation in extreme cases. The motor should be protected with a corrosion inhibiting spray and any rust should be removed and the motor repainted.

Spare Parts List

* See exploded view (pg 4) for explanation of parts key

(A) Pump Head Kit	50834-0000
(B) Seal Kit	50835-0000
(C) Motor Kit (12V)	50836-0012
Motor Kit (24V)	50836-0024

KEY	DESCRIPTION	KIT KEY			QTY PER KIT
		A	B	C	
1	End Cover	1			1
2	Screws	5	5		5
3	O-Ring	1	1		1
4	Locking Nut	1	1		1
5	Impeller	1			1
6	Seal		1		1
7	Housing	1			1
8	Slinger		1		1
9	Motor			1	1

Wiring Instructions

Make all electrical connections in dry locations, connections in humid environments should be sealed to prevent corrosion. Protect the circuit with a rated fuse or circuit breaker in the red positive (+) lead as close as possible to the power source. Connect the black motor wire to the negative (-) battery terminal. Inadequate voltage at the motor terminals when the pump is running (not less than 10% below rated voltage at full load) due to partially discharged batteries or insufficient cable size may result in blowing fuses, failure to start or poor pump performance.

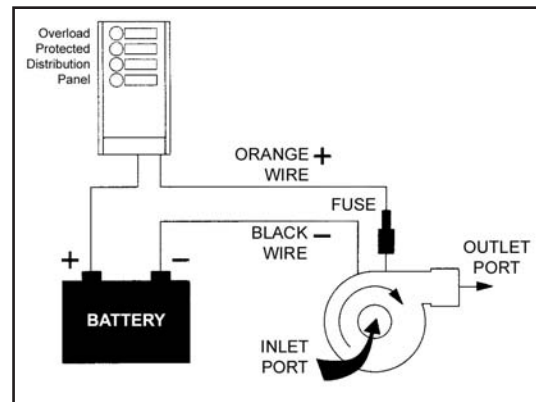

Wiring Diagram

Electrical Wiring Information

Model No.	Voltage	Max Amp Draw	Max Fuse Size
50830-0012	12V	7A	10A
50830-0024	24V	3.5A	5A

Wire Length Between Battery and Motor	AWG	
	12V	24V
1-10 ft (3m)	12	16
11-20 ft (6m)	10	16
21-30 ft (9m)	8	12



WARNING: If the fuse fails repeatedly do not fit a heavier fuse or bridge the fuse terminals with silver paper or metal wire. Failure to observe this instruction may result in a fire hazard due to overheating of cables.



50830 Series Low Pressure Centrifugal Pump

Dis - Assembly

1	Remove 3 end cover bolts	
2	Remove impeller nut	
3	Remove impeller	
4	Loosen 2 fixing bolts and rotate body to remove	
5	Remove seal from pump body	
6	Remove ceramic seal face from body	

Re - Assembly

1	Place ceramic seal face in pump body	
2	Re-fit body to motor and rotate to fit. Tighten fixing bolts	
3	Place seal over shaft and push fit in place	
4a	Replace impeller and tighten nylock nut to maximum	
4b	At maximum reverse and take one complete turn off	
5	Replace end cover	
6	Tighten 3 fixing screws	



50830 Series Low Pressure Centrifugal Pump

Dimensional Drawing

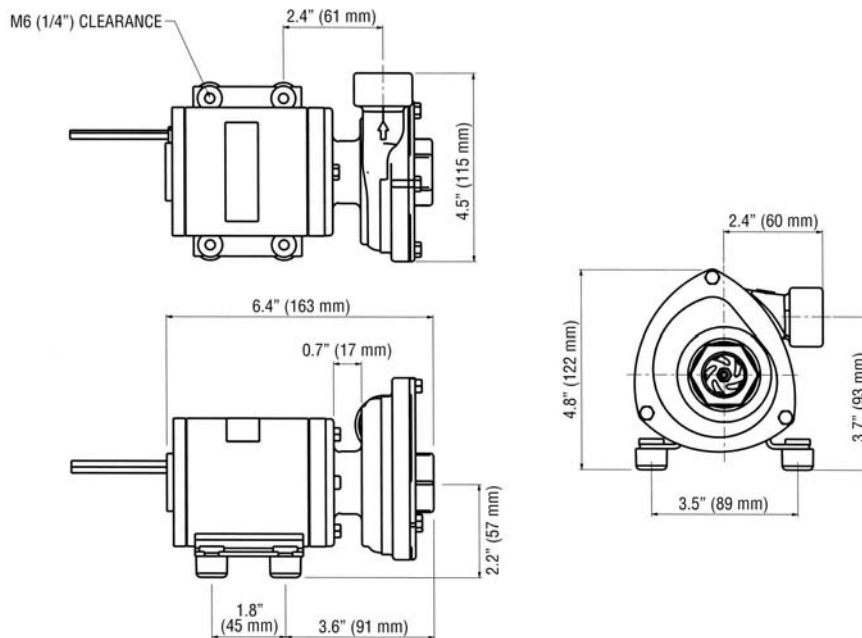

Exploded View

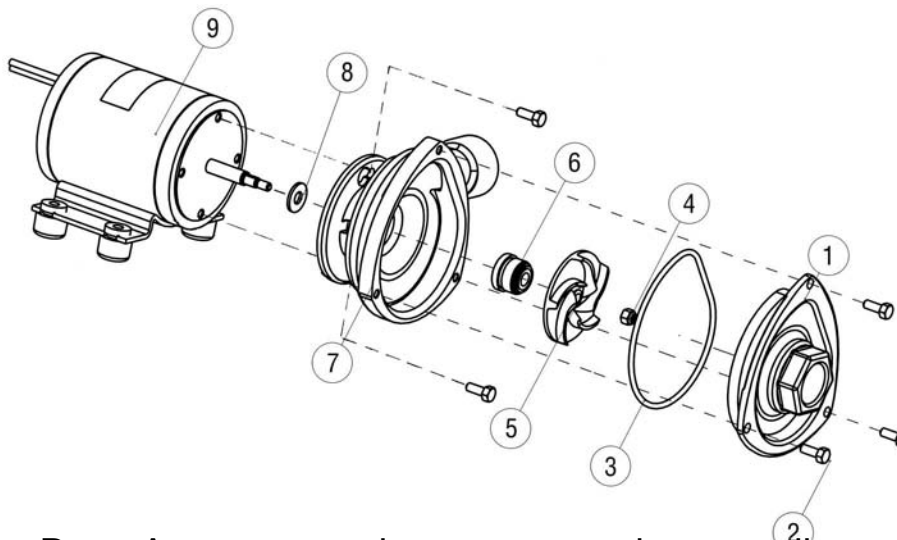

For technical advice or service please take your pump into your local pump service center.
To order pump or parts or for pricing please go to the following links :

[Jabsco Pumps Home >>](#)

[Jabsco Pumps stock list >>](#)