



## Model 36740-Series

### FLEXMOUNT 3" BLOWERS

#### FEATURES

- Tough Reinforced Plastic Housing
- Universal Flexmount Bracket Permits Outlet to Face Any Direction
- Slip-On Inlet and Outlet Ducting Connection
- Efficient High Volume Airflow
- Low Current Draw
- Corrosion-Resistant Materials Throughout
- N.M.M.A. Type Accepted
- Meets USCG Regulation 183.410 and ISO 8846 MARINE for Ignition Protection
- DC Models Comply with ISO 9097 MARINE



Model 36740-Series

#### INSTALLATION

INSTALLATIONS MUST MEET APPLICABLE SECTIONS OF TITLE 33, PART 183; SUBPART K, USCG VENTILATION REGULATIONS.

**MOUNTING:** Jabsco blowers are primarily intended for intermittent duty cycles such as evacuating fuel vapors from bilge areas. If desired, they also may be used for other general air circulation applications with longer duty cycles. However, when doing so, it should be noted that the maximum motor life is approximately 1000 hours. Therefore, the blower should only be used for applications if this length of service is acceptable. For continuous duty applications, ask your dealer about Jabsco Heavy Duty Long Life Blowers. Mount blower on flat bulkhead surface in highest part of compartment free from spray or deck wash. Blower may be rotated in mounting bracket to facilitate the shortest route of ducting. Use a suitable discharge fitting so that static pressure of blower will not be affected by change in wind direction. Route inlet ducting with as few bends as possible to lower 1/3 of the bilge compartment where vapors are likely to accumulate. Be sure ducting is positioned below top of engine stringers but not so low as to become submerged in bilge water. Locate pickup to take advantage of natural airflow direction. Jabsco flexible ducting No. 34959-0100 is easy to cut and install.

#### NOTICE:

Blower should be mounted away from extreme heat (more than 130°F) to prevent distortion of blower wheel or housing.

For an exposed inlet, ventilator intake screen No. 34764-0000 provides a safe and attractive protected inlet.

**OPERATION:** See following warning placard statement.

	<p><b>Explosion hazard. Gasoline vapors can explode. Before starting engine, operate blower for 4 minutes and check engine compartment bilge for gasoline vapors. Run blower below cruising speed. Failure to do so can result in injury or death.</b></p>
--	--

#### SPECIFICATIONS

Model	Airflow	Voltage	Amps	Fuse Size	Weight lb(kg)
36740-0000	150 CFM (4,2 m <sup>3</sup> /min.)	12 Vdc	6.8	10A	5.5 (2,5 kg)
36740-0010	150 CFM (4,2 m <sup>3</sup> /min.)	24 Vdc	3.3	5 A	5.5 (2,5 kg)
36740-0031	140 CFM (4,0 m <sup>3</sup> /min.)	115 Vac	0.8	1.25 A 115 V	5.0 (2,3 kg)

#### INSTALLATION DRAWING

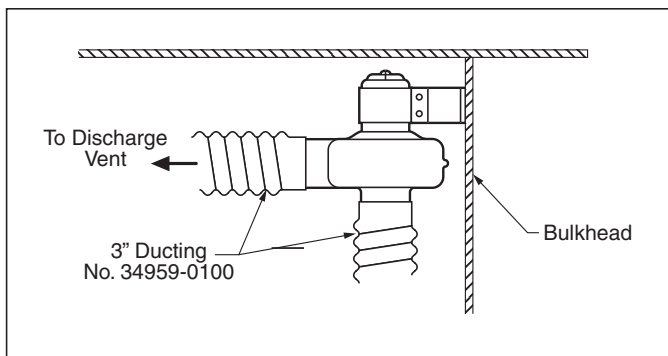

THE "WARNING" PLACARD SUPPLIED WITH BLOWER MUST BE MOUNTED ADJACENT TO ENGINE IGNITION SWITCHES (ALL LOCATIONS) TO COMPLY WITH TITLE 33, PART 183; SUBPART K, USCG VENTILATION REGULATIONS. \*

\*Additional warning placards are available from factory by requesting form 43003-0418.

**PARTS LIST**

Key	Part Description	Part Number	Qty.
1	Bracket Assembly (includes screw & nut)	43899-000	1
2	Motor Kits:		
	12Vdc	30200-0000	
	24Vdc	30200-0010	
	115 Vac	30200-0050	
3	Blower Housing	35772-0000	1
4	Blower Wheel	34742-0001	1
5	Blower Housing	35773-0000	1
6	Screw - 8 x 5/8 SS Self Tapping Pan Head	35508-0000	5

**PARTS VIEW**

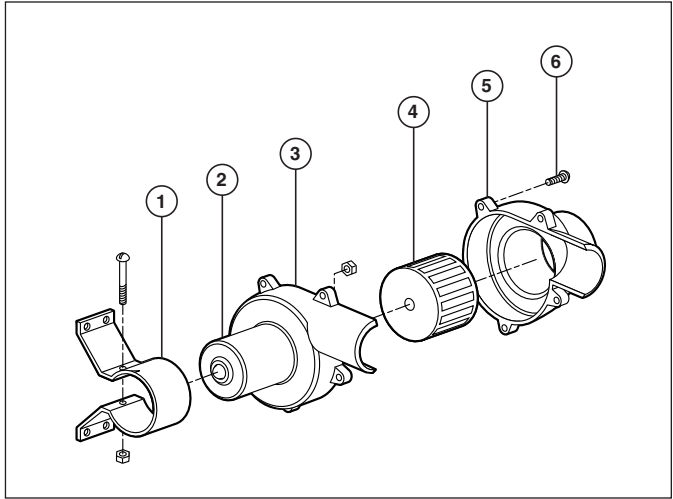

**MARINE SWITCH PANELS**

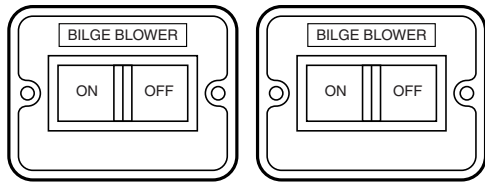

**44960-0002**  
Lighted Switch with  
Boot SPST  
(For DC Blowers Only)

**44960-0003**  
Unlighted SPST  
(For AC or DC Blowers)

**DIMENSIONAL DRAWING**

Inches (millimeters)

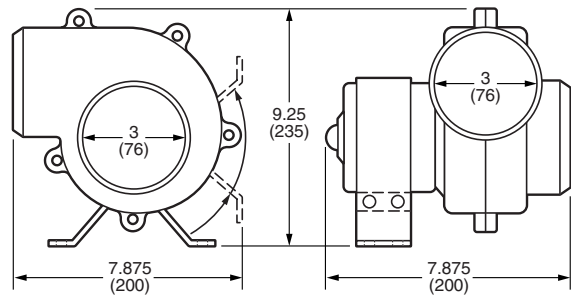

**WIRING FOR DC MODELS**

Use stranded copper wire. For lengths up to 25 feet (7.6 m) from power source: use 12 gauge wire for 12 Volt, 14 gauge wire for 24 Volt. Use larger wire for longer lengths. Use a 10 amp rated on-off switch in positive side of circuit (Model 44960-0003). Circuit must be protected with a fuse. Suggested fuse sizes are listed in the specifications table.

**WIRING FOR AC MODEL**

Use 16 gauge stranded copper wire for lengths up to 100 feet from power source. Connect the grounded, unswitched conductor (white) to the white motor lead. Connect the ungrounded, switched conductor (black) to the black motor lead. This conductor should include, at the power source, a 1.25 amp 125 Volt fuse. The green motor lead must be connected to the AC circuit ground.

Model 36740-0000

12 VDC

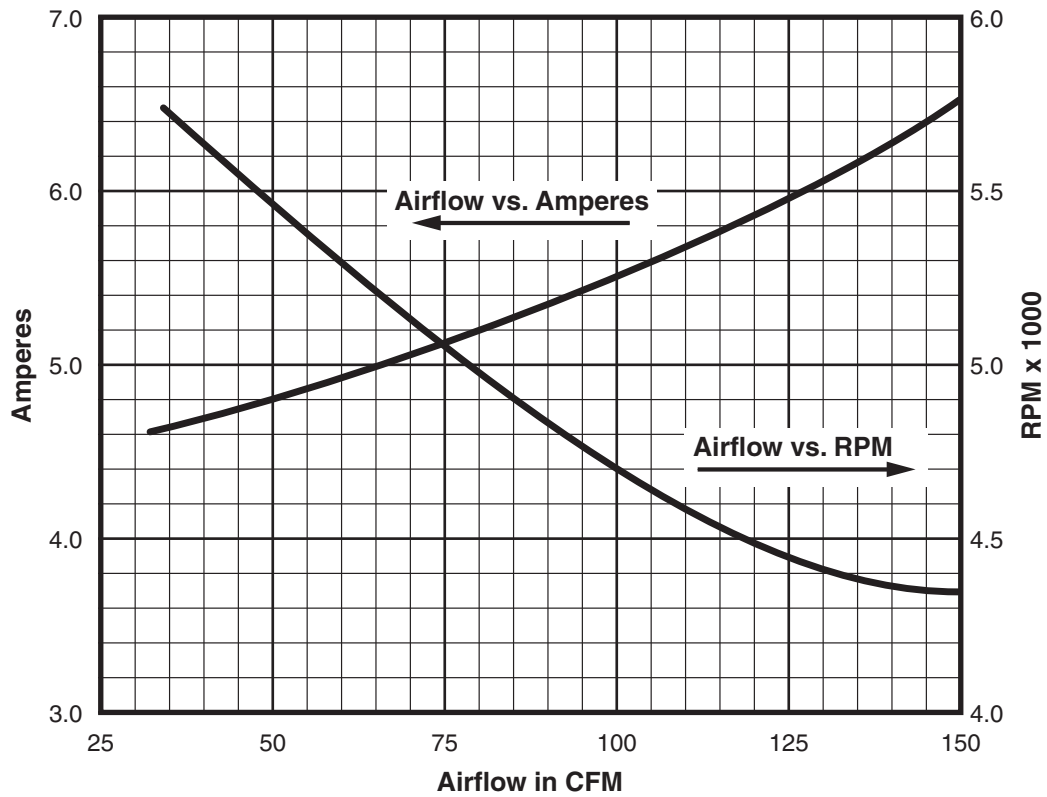

Model 36740-0010

24 VDC

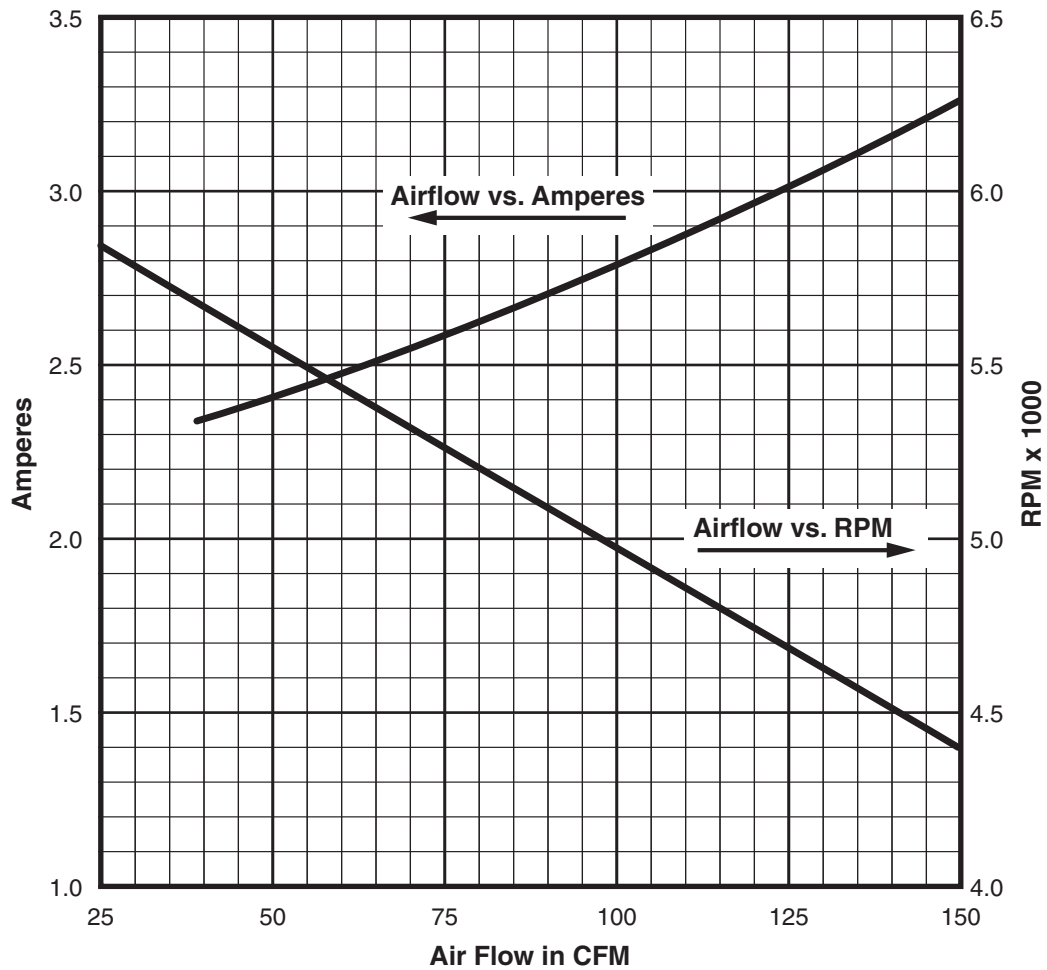

Model 36740-0031  
115 VAC

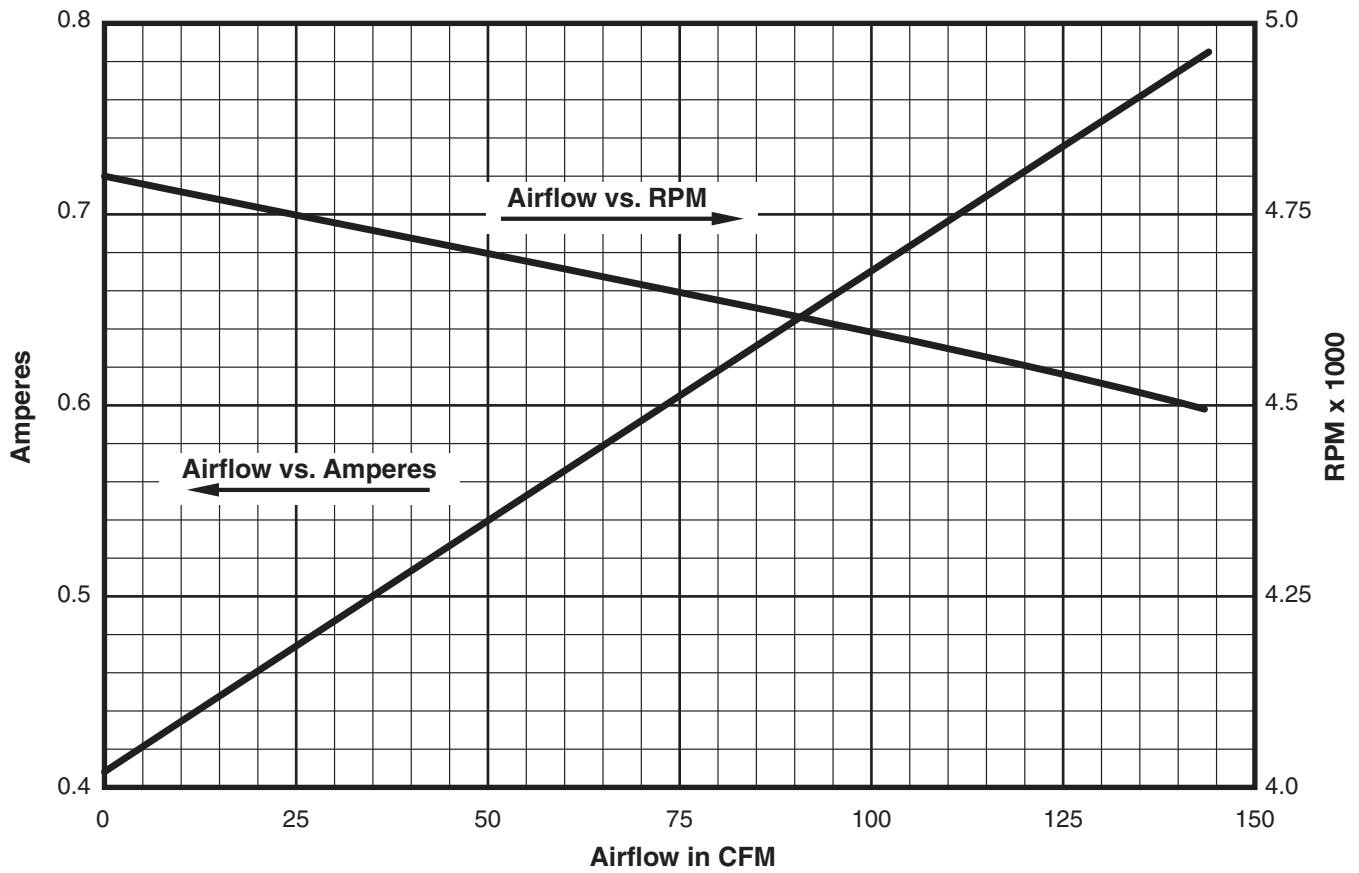

For more information  
visit us online at [www.jabsco.com](http://www.jabsco.com)