

JABSCO' PUMPS

Self Priming Pumps

MODEL 3590-9001

Product Data

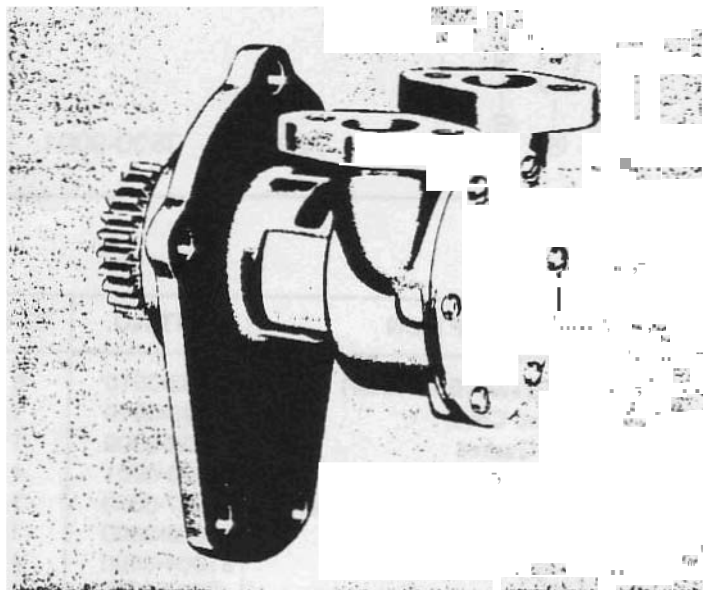

MOEEL 3590-900'

DESIGN FEATURES

- Body: **Bronze**
- Impeller: **Jabco** Neopnme Compound
- Shaft: **Bronze**
- Shaft Seal: **Carbon-Ceramic Face Type**
- Ports: **7"**
- Weight: Approx. shipping **weight 7 lbs.**

APPLICATION:
Marine Engine Cooling

FOR ENGINE MODELS:
Chrysler Ace, Crown, and Royal
M-46, M-47. and M48.
Ace & Crown M-46-3 & M-47-3.

MODEL 3590-900

DIMENSION DRAWING

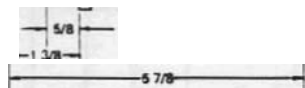
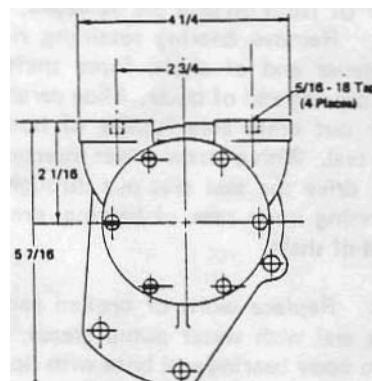
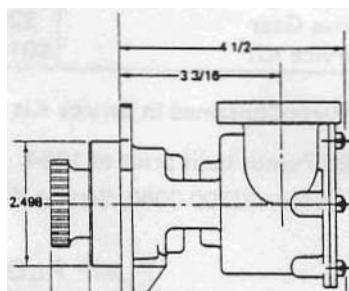

Installation Instructions

Make **sure** flange **seats** squarely on mounting surface and bolt to engine. Connect inlet and **outlet fittings**. Intake and **discharge** piping of **the** engine must correspond **with** the proper port markings on **the** pump.

Operating Instructions

Pump will self prime at low or high **speeds**. Make sure \$Coop and inlet line are clear and **all** connections air tight. OO not fun pump dry for more **than 30 seconds**. Lack of water flow may damage impeller. To drain pump, loosen end **cover** screws.

JABSCO PRODUCTS



EXPLODED VIEW

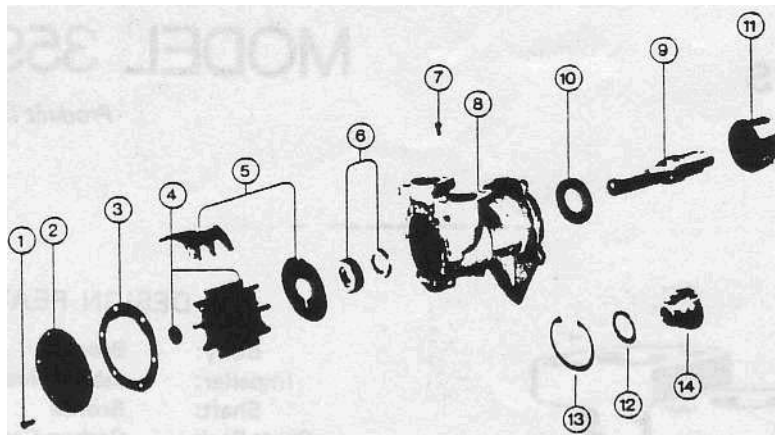

MODEL: 3590-9001

Service Instructions

Impeller Replacement: Remove end cover and gasket. Pull impeller out by grasping hub or blades with **pliers**. Replace impeller, gasket, and end cover. A light coating of grease in impeller bore **will** aid priming on dry start up. (Use correct **Jabsc** gasket; a thicker or thinner gasket may cause impeller damage.) Standard gasket is .010" thick.

Major Repair: Remove pump from engine to replace seal assembly, bearings, or **shaft**.

Disassembly: Remove end cover and gasket. Remove **impeller**. Loosen **cam** screw and tap down to loosen cam. Remove cam screw, cam, and wearplate (wipe **off** permatex). Using a gear puller, remove drive gear from **shaft** without damaging gear (**if** teeth on gear are damaged, the gear must be replaced). Remove bearing retaining ring (Key 13). Press on **impeller** end of shaft, force shaft and bearing assembly out bearing end of body. Slide ceramic portion of seal assembly out drain area (center of body). Remove inner bearing seal. With a screw driver inserted through the bearing bore, drive **the** seal seat out through the impeller bore. Supporting inner race of bearing, press bearing off over drive end of shaft.

To Assemble: Replace worn or broken parts. Lubricate inner bearing seal with water pump grease, or equivalent, and press into body bearing seal bore with **lip** facing flange. Press bearing onto well-oiled shaft. Place shaft and bearing assembly (splined end first) into body bearing bore and press on bearing outer race until in place. Install bearing **re**-taining ring. Slip spacer over drive end of shaft and up against bearing. Supporting splined end of shaft, press drive gear onto drive end of shaft. Place ceramic portion of seal **assembly** over **splined** end of shaft and back against shaft shoulder (flat side of ceramic seat must face impeller bore). Lubricate with water (do not use oil) to ease assembly. Lightly Permatex O.O. surface of seal case and with carbon facing ceramic, press on outer edge of seal seat until flush **with** rear of body impeller bore. Install wearplate with small notch facing up. Permatex threads of cam screw and **top** of cam and install loosely. Lubricate impeller bore with a light coat of water pump grease and **install** impeller. Install gasket and **end** cover. Tighten cam screw.

KEY	DESCRIPTION	PART NO.	QTY.
1	Screws (End Cover)	91003-0010	6
2	End Cover	3595-0010	1
3	* Gasket	2432-0000	1
●	• Impeller	920-0001	1
5	Cam & Wearplate Assembly	7957-0000	1
6	* Seal (Shaft)	96080-0080	1
7	Cam Screw	91004-0090	1
B	Body	3594-9000	1
9	Shaft	3597-0410	1
10	Seal (Bearing)	92700-0200	1
11	Ball Bearing	92600-0060	1
12	Spacer	3912-0000	1
13	Retaining Ring (Bearing)	91701-1850	1
"	Drive Gear	3296-0000	1
	Service Kit	90118-0001	

• Parts Contained in **Service** Kit

Model 3590 Pumps built **prior** to 1964.

Use Lip Seal No. 92700-0060, Service **Kit** No. 90010-0001

PUMP FLOW CHART

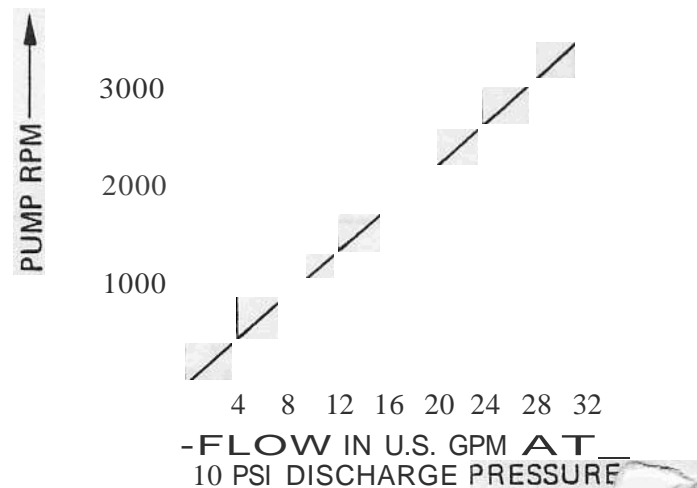

JABSCO PRODUCTS

Marine and Recreation Components Division
International Telephone and Telegraph Corporation
1485 Date Way, Costa Mesa, California 92626

Telephone: (714) 545-8251

For technical advice or service please take your pump into your local pump service center.
To order pump or parts or for pricing please go to the following links :

[Jabsco Pumps Home >>](#)

[Jabsco Pumps stock list >>](#)