



Model 34875-0000

AUTOMATIC BILGE PUMP CONTROL

FEATURES

- Hydro Air Control
- Mounts High and Dry
- Adjustable Level Setting
- No Wiring Below Water

SPECIFICATIONS

Factory set to turn on at 2" and off at 1/2".

Electrical: 6 to 32 Vdc at 6 Amp
115 Vac at 10 Amp

Tubing: 1/4" x 10 Feet

APPLICATION

Jabco "Hydro Air" bilge pump control for safe, reliable, fully automatic pump operation. Water rising or falling in the bilge transmits air pressure through tubing to switch and turns pump on or off. Easy to install; wiring mounts high and dry in convenient location. Only the plastic air bell is in the bilge, set to turn on at approximately 2" and off at approximately 1/2". Adjustable level setting for varying installations. Includes switch, air bell and 10 feet of tubing.



Model 34875-0000

- DESIGNED FOR:**
- Automatic Bilge Pump Operation
 - High Water Level Alarm
 - Low Level Cut-off Switch
 - Electric Clutch Actuator

DIMENSIONAL DRAWINGS

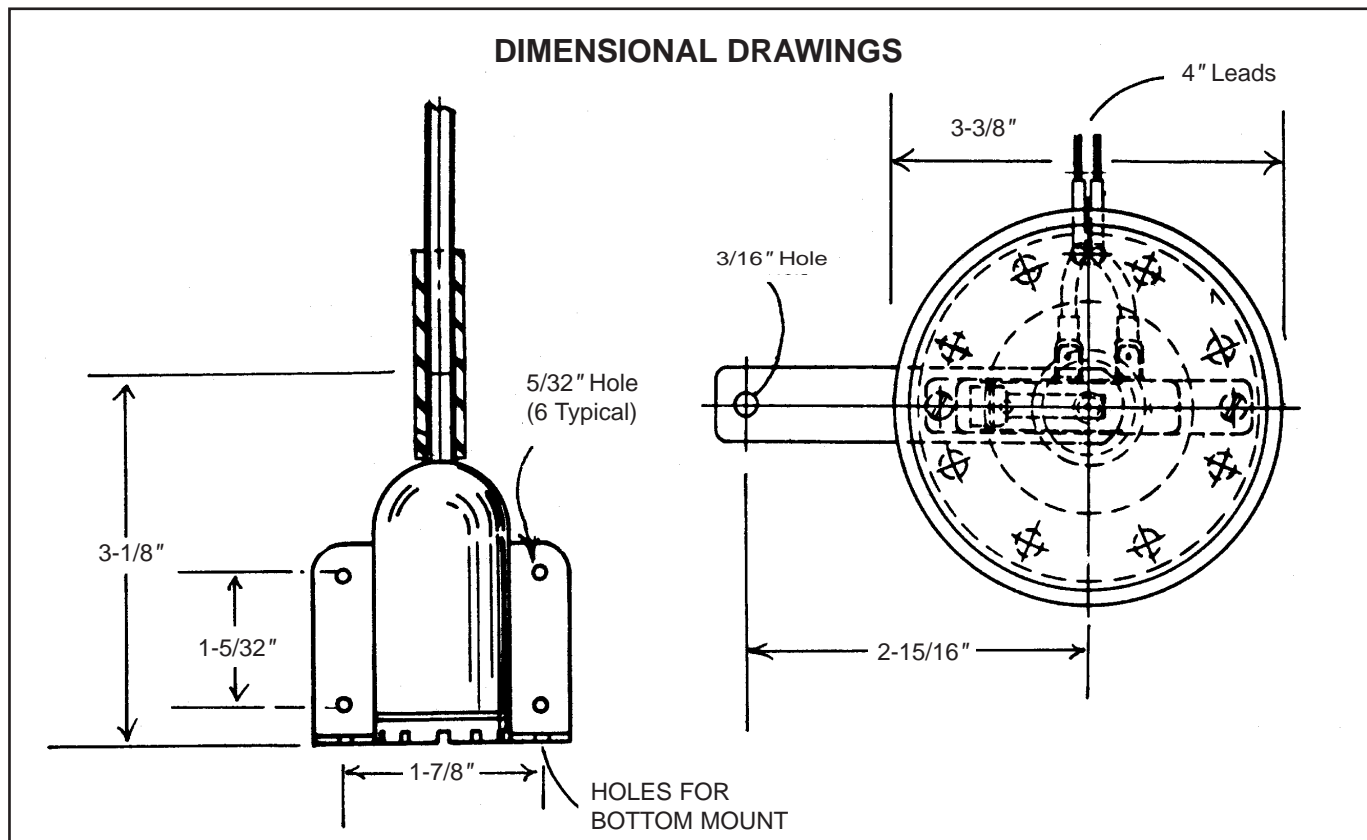

INSTALLATION AND OPERATION

	<p>WARNING Explosion hazard. Switch can spark causing an explosion. Property damage, injury or death can occur. Do not install switch where flammable vapors are present.</p>
---	--

Switch assembly should be located outside engine room in any cool dry place where flammable vapors can not accumulate.

The high engine room temperature expands the air in the switch and may cause false operation.

Switch transmitter bell and strainer should be mounted in deepest point in hull when boat is at anchor.

Unit is supplied with 10' of plastic tubing. Length should be cut to suit installation and routed from sensing bell to switch unit to avoid trapped condensation.

NOTICE: If air line between switch and bell is taken apart during installation, care should be taken when connections are replaced to make sure they are airtight. These connections are a force fit to prevent leakage at these points.

To assure proper operation, it is very important that no water is in tubing or bell at time of installation, as this will cause the switch to turn off and on at undesirable heights.

It is also necessary, at intervals, if pump doesn't drain water to level below the bottom of the bell, to vent bell to atmosphere to maintain top switch efficiency. This is done by raising bottom of bell above top of water level and replacing very slowly.

Bell should be checked periodically to see that no foreign matter has accumulated inside or around bottom of skirt preventing rise of water in bell and causing faulty operation.

WIRING INSTRUCTIONS:

If switch is to be used in automatic system only, wire as shown in Figure 1.

If switch is to be used in automatic and manual systems, wire as shown in Figure 2.

TO ADJUST SWITCH:

Switch is adjusted at factory to turn on at approximately 2" and off at 1/2".

If switch is required to turn on at a higher or lower level than adjusted for at the factory, remove snap-on cover and turn screws counterclockwise for a higher level and clockwise for a lower level.

If switch fails to turn pump off when water level has been lowered, turn adjustment screws counterclockwise until pump stops.

Adjust screws equally 1/4 turn at a time.

The level of water required to activate switch may also be varied by moving the transmitter bell higher off bottom for more depth, and closer to the bottom for less depth.

FIGURE 1
DIAGRAM FOR WIRING AUTOMATIC

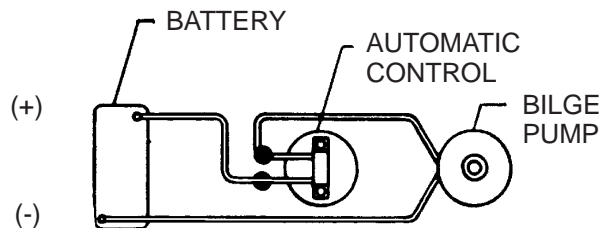
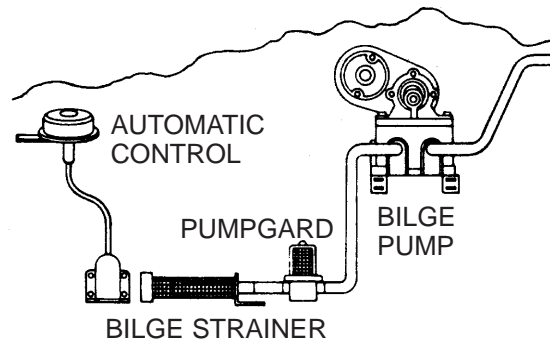
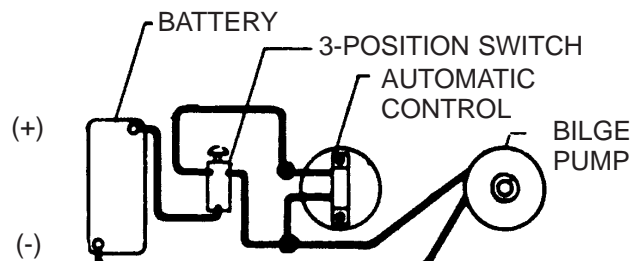

FIGURE 2
DIAGRAM FOR WIRING AUTOMATIC AND MANUAL



Automatic Bilge Pump and Control Installation

Self-priming Jabsco bilge pumps run dry without damage. High capacity strainer, 35890-Series, fits vee bottom. Automatic control gives reliable automatic bilge pumping even when the boat is unattended. Pumpgard® in-line strainer gives added protection to keep debris from clogging the pump.

REPLACEMENT PARTS

Cover, Red Rubber	34242-0000
Switch	34852-0000
Air Tube, 10' x 1/4"	33815-0010
Air Tube Connectors (2)	33765-0010
Air Bell	35408-0000

Jabsco



ITT Industries
Engineered for life



PumpAgents.com buy pumps and parts online

THE PRODUCT DESCRIBED HEREIN IS SUBJECT TO THE JABSCO ONE YEAR LIMITED WARRANTY, WHICH IS AVAILABLE FOR YOUR INSPECTION UPON REQUEST.

For technical advice or service please take your pump into your local pump service center.
To order pump or parts or for pricing please go to the following links :

[Jabsco Pumps Home >>](#)

[Jabsco Pumps stock list >>](#)